

**CHARTER TOWNSHIP OF SUPERIOR  
REGULAR BOARD MEETING  
SUPERIOR CHARTER TOWNSHIP HALL  
3040 N. PROSPECT, SUPERIOR TOWNSHIP, MI 48198**

**July 16, 2018**

**7:00 p.m.**

**AGENDA**

1. CALL TO ORDER
2. PLEDGE OF ALLEGIANCE
3. ROLL CALL
4. ADOPTION OF AGENDA
5. APPROVAL OF MINUTES
  - a. Regular Meeting of June 18, 2018
6. CITIZEN PARTICIPATION
7. PRESENTATIONS AND PUBLIC HEARINGS
  - a. Introduction of new WCRC Managing Director, Sheryl Siddall
  - b. Harvest Lane Sewer Options – George Tsakoff, OHM
  - c. Cannabis Legal Group – Craig Aronoff
  - d. Third Coast of Ypsilanti, LLC – Darrell Stavros
8. REPORTS
  - a. Supervisor
  - b. Departmental Reports: Building Department, Fire Department, Ordinance Officer, Parks Commission Minutes, Sheriff's Report
9. COMMUNICATIONS

None
10. UNFINISHED BUSINESS

None
11. NEW BUSINESS
  - a. Resolution 2018-17, To Approve an Agreement Between Superior Township and the Washtenaw County Road Commission for 2018 Road Improvements
  - b. Resolution 2018-18, To Approve the Timberwood Court Road Improvement Agreement
  - c. Resolution 2018-19, To Approve the Agreement with Nimble IT Systems
  - d. Resolution 2018-20, FEMA Regional Wide Grant

- e. Motion to Approve Camera Bid
- f. Motion to Approve Door Operator Bid
- g. Region 9 Veterans Community Action Team Request for Gaming Approval
- h. Request from Miller Canfield to Represent Chinese School at 5800 Cherry Hill Road
- i. Huron River Watershed Council Dues 2018
- j. Washtenaw County Clean-Up Day Sponsorship

12. BILLS FOR PAYMENT AND RECORD OF DISBURSEMENTS

13. PLEAS AND PETITIONS

14. ADJOURNMENT

Lynette Findley, Clerk, Superior Township, 3040 N. Prospect, Superior Township, MI 48198  
Telephone: 734-482-6099; Email:lynettefindley@superior-twp.org

**There will be a meeting of the Superior Township Election Commission immediately after the Board meeting.**

**CHARTER TOWNSHIP OF SUPERIOR BOARD  
REGULAR MEETING  
JUNE 18, 2018  
PROPOSED MINUTES  
PAGE 1**

**1. CALL TO ORDER**

The regular meeting of the Charter Township of Superior Board was called to order by the Supervisor Ken Schwartz at 7:00 p.m. June 18, 2018 at the Superior Township Hall, 3040 North Prospect, Superior Township, Michigan.

**2. PLEDGE OF ALLEGIANCE**

Supervisor Schwartz led the assembly in the pledge of allegiance to the flag.

**3. ROLL CALL**

The members present were Ken Schwartz, Brenda McKinney, Lynette Findley, Lisa Lewis, Alex Williams, Rodrick Green, and Nancy Caviston.

Absent: None

**4. ADOPTION OF AGENDA**

It was moved by McKinney, supported by Caviston, to adopt the agenda as presented.

The motion carried by unanimous vote.

**5. APPROVAL OF MINUTES**

**A. REGULAR MEETING OF MAY 21, 2018**

It was moved by Lewis, supported by Caviston, to approve the minutes of the regular board meeting of May 21, 2018.

The motion carried by unanimous vote.

**6. CITIZEN PARTICIPATION**

- John Nydam, a citizen of the township, thanked the board for fixing Prospect Road. He also discussed enforcing seasonal weight restrictions for trucking companies that drive the roads. He thinks if a restriction is not enforced that Prospect Road will be destroyed in 2 to 3 years.
- He also commented on the gypsy moth infestation this year. He believes this is the third year of gypsy moths overrunning the area.

**CHARTER TOWNSHIP OF SUPERIOR BOARD  
REGULAR MEETING  
JUNE 18, 2018  
PROPOSED MINUTES  
PAGE 2**

**7. PRESENTATIONS AND PUBLIC HEARINGS**

A. Benjamin Carlisle, LEED, AICP, Principal with Carlisle | Wortman Associates, Inc., submitted their proposed scope of planning services to the board. The township has parted with Pennington Planners and needed to acquire a new firm for planning services.

Carlisle | Wortman Associates, Inc. represent about 80 communities in the state. They have 20 planners on staff. Benjamin Carlisle will be the day to day contact for the township.

B. Ken Palka of Pfeffer, Hanniford and Palka, CPA's presented the township's FY 2017 Audit:

- Total General Fund expenditures exceeded revenues by \$99,849.00 due to spending on road repair. Total expenditures in the Fire Fund exceeded revenues by \$41,034.00 and Law Fund expenditures exceeded revenues by \$20,745.00. There was a surplus on all other funds of \$115,434.00. All combined there was a small decrease in the fund balance of \$44,044.00.
- The Water and Sewer Fund had a small surplus of \$80,083.00.
- The General Fund combined with the Parks and Recreation Fund, due to the General Fund supporting the Parks and Recreation Fund, had a small loss of \$97,699.00.
- Overall operating revenue was \$779,512.00.
- Total capital assets are \$15,430,906.00.
- Pie Chart 1 - The chart shows 50% of the townships revenue comes from the state at \$1,123,216.000. The second largest source of revenue comes from taxes in the amount of \$523,881.00.
- Graph 2 - Shows a comparison of the Fund Balance from 1994-2017. The Fund Balance was lower in 2017 due to road repairs.
- Graph 3 - Shows a comparison of the Utility Fund Balance from 1995-2017. Over the years revenues have exceeded expenditures.
- Pie Chart 2 - Shows the General Fund Fund Balance total of \$1,774,713.00 with \$1,704,002.00 being undesignated.
- Pie chart 3 - Shows the Parks Fund with a balance of \$577,692.00 with \$184,025.00 being undesignated and \$383,157.00 going towards building reserves.
- Pie Chart 4 - Shows the Fire Fund with a balance of \$2,550,713.00 with \$1,491,018.00 being undesignated.
- Pie Chart 5 - Shows the Building Fund with a balance of \$773,284.00.
- Pie Chart 6 - Shows the Water and Sewer Fund with total restricted cash and cash equivalents of \$3,584,339.00 included in that is a capital reserve of \$1,971,180.00.

**CHARTER TOWNSHIP OF SUPERIOR BOARD  
REGULAR MEETING  
JUNE 18, 2018  
PROPOSED MINUTES  
PAGE 3**

- Pie Chart 7 - Shows the Law Fund with a balance of \$257,155.00.

It was moved by McKinney, supported by Lewis, to receive and accept the findings of the Charter Township of Superior FY2017 Audit Report as presented.

The motion carried by unanimous vote.

The audit will be submitted to the state on Tuesday.

**8. REPORTS**

**A. SUPERVISOR REPORT**

Supervisor Schwartz reported on the following:

- The township was awarded \$10,000.00 from Community Tourism Action Plan (CTAP) for the Dixboro Village Green pavilion.
- Utilizing Right-of-Way Monies, Lucas Nursery will be installing 16 pear trees in the right-of-way on Geddes from Andover to Harris. The total cost will be around \$2500.00.
- No update on Salem Township's Gotfredson sewer plans. The supervisor did receive all the Michigan Economic Development Corporation (MEDC) documents regarding the project.
- The Dixboro House plans have been approved by the township. They still have some work to do with the Washtenaw County Road Commission and the Washtenaw County Water Resources Commission. Their goal is to have work completed by the end of the year.
- There was a phone conference two weeks ago with the Peninsular Dam working group regarding the removal of the Peninsular Dam. The township has about 7 residents who have houses behind the dam and hold riparian rights on the pond. They are adamantly opposed to the removal of the dam. The dam is owned by the City of Ypsilanti and the township does not have a say in what happens to the dam. The City of Ypsilanti has funding for removal of the dam not for repair. The township is working to ensure that the residents do not lose their riparian rights.
- The administrative staff met today with Ypsilanti District Library (YDL) and the library's architects regarding the plans for the Superior Township branch of the Ypsilanti District Library. If the library millage passes in November the YDL is committing all of its reserves to the new library. The funds generated by the millage would go towards operations for the future.
- The supervisor discussed increasing compensation to attract employees to the township. He also discussed upgrading resources in order for the township to better service the community by way of transitioning the township's files to a digital format.

**CHARTER TOWNSHIP OF SUPERIOR BOARD  
REGULAR MEETING  
JUNE 18, 2018  
PROPOSED MINUTES  
PAGE 4**

**B. DEPARTMENT REPORTS: BUILDING DEPARTMENT, FIRE DEPARTMENT, ORDINANCE OFFICER REPORT, PARKS COMMISSION MINUTES, SHERIFF'S REPORT**

It was moved by McKinney, supported by Green, that the Superior Township Board receive all reports.

The motion carried by unanimous vote.

**C. UTILITY DEPARTMENT FINANCIALS, PERIOD ENDING MARCH 31, 2018**

It was moved by Lewis, supported by Caviston, that the Superior Township Board receive the utility department financials, period ending March 31, 2018.

The motion carried by unanimous vote.

**D. FINANCIAL REPORTS, ALL FUNDS AS OF MARCH 31, 2018**

It was moved by Caviston, supported by Lewis, that the Superior Township Board receive the financial reports, all funds as of March 31, 2018.

The motion carried by unanimous vote.

**E. CONTROLLER'S REPORT, 1<sup>ST</sup> QUARTER, 2018**

It was moved by Green, supported by Caviston, that the Superior Township Board receive the controller's report, 1<sup>st</sup> quarter, 2018.

The motion carried by unanimous vote.

**9. COMMUNICATIONS**

None

**10. UNFINISHED BUSINESS**

**A. ORDINANCE 174-21, FLEMING CREEK ZONING ORDINANCE TEXT AMENDMENT, SECOND READING AND ADOPTION**

The ordinance amendment will require that commercial developments and subdivisions submit, as part of their site plan, technical information to the Fleming Creek Advisory Council for review and an advisory opinion.

**CHARTER TOWNSHIP OF SUPERIOR BOARD  
REGULAR MEETING  
JUNE 18, 2018  
PROPOSED MINUTES  
PAGE 5**

It was moved by Williams, supported by Findley, to approve the Fleming Creek Zoning Ordinance Text Amendment, Second Reading and Adoption.

Roll call:

Ayes: Green, Caviston, Williams, Findley, Lewis, Schwartz, McKinney

Nays: None

The motion carried by unanimous vote.

**B. ORDINANCE 169, AMENDING UTILITY ORDINANCE NO. 169, SECOND READING AND ADOPTION**

The township prohibits private parties or other entities from running water or sewage lines in all road right-of-ways within the township that will serve areas outside the township without authorization from the township.

It was moved by Caviston, supported by Green, to approve the Utility Ordinance No 169 amendment.

Roll call:

Ayes: Schwartz, Findley, Lewis, Williams, Green, McKinney, Caviston

Nays: None

The motion carried by unanimous vote.

**11. NEW BUSINESS**

**A. RESOLUTION 2018-13, AUTHORIZING JULY AS PARKS & RECREATION MONTH**

This is an annual resolution that recognizes July as Parks & Recreation Month.

It was moved by McKinney, supported by Caviston, to recognize July as Parks & Recreation Month.

**CHARTER TOWNSHIP OF SUPERIOR  
WASHTENAW COUNTY, MICHIGAN**

**RESOLUTION AUTHORIZING JULY 2018 AS  
PARKS & RECREATION MONTH**

**Resolution Number: 2018-13**

**Date: June 18, 2018**

**DESIGNATION OF JULY AS PARK AND RECREATION MONTH**

**WHEREAS**, parks and recreation programs are an integral part of communities throughout this country, including the Charter Township of Superior; and

**WHEREAS**, our parks and recreation are vitally important to establishing and maintaining the quality of life in our communities, ensuring the health of all citizens, and contributing to the economic and environmental well-being of a community and region; and

**WHEREAS**, parks and recreation programs build healthy, active communities that aid in the prevention of chronic disease, provide therapeutic recreation services for those who are mentally or physically disabled, and also improve the mental and emotional health of all citizens; and

**WHEREAS**, parks and recreation programs increase a community's economic prosperity through increased property values, expansion of the local tax base, increased tourism, the attraction and retention of businesses, and crime reduction; and

**WHEREAS**, parks and recreation areas are fundamental to the environmental well-being of our community; and

**WHEREAS**, parks and natural recreation areas improve water quality, protect groundwater, prevent flooding, improve the quality of the air we breathe, provide vegetative buffers to development, and produce habitat for wildlife; and

**WHEREAS**, our parks and natural recreation areas ensure the ecological beauty of our community and provide a place for children and adults to connect with nature and recreate outdoors; and

**WHEREAS**, the U.S. House of Representatives has designated July as Parks and Recreation Month; and



**CHARTER TOWNSHIP OF SUPERIOR BOARD  
REGULAR MEETING  
JUNE 18, 2018  
PROPOSED MINUTES  
PAGE 7**

**WHEREAS**, the Charter Township of Superior recognizes the benefits derived from parks and recreation resources

**NOW THEREFORE, BE IT RESOLVED** that the Superior Charter Township Board of Trustees, that July is recognized as Park and Recreation Month in the Charter Township of Superior

**CERTIFICATION STATEMENT**

I, Lynette Findley, the duly qualified Clerk of the Charter Township of Superior, Washtenaw County, Michigan, do hereby certify that the foregoing is a true and correct copy of a resolution adopted at a regular meeting of the Superior Charter Township Board held on June 18, 2018 and that public notices of said meeting were given pursuant to Act No. 267, Public Acts of Michigan, 1976, as amended.

\_\_\_\_\_  
Lynette Findley, Township Clerk

\_\_\_\_\_  
Date Certified

The motion carried by unanimous vote.

**B. RESOLUTION 2018-14, TO APPROVE AN AGREEMENT BETWEEN SUPERIOR TOWNSHIP AND THE WASHTENAW COUNTY ROAD COMMISSION FOR 2018 ROAD IMPROVEMENTS**

It was moved by Findley, supported by Lewis, to approve the agreement between the township and the Washtenaw County Road Commission for 2018 road improvements.

**SUPERIOR CHARTER TOWNSHIP  
WASHTENAW COUNTY, MICHIGAN**

**A RESOLUTION TO APPROVE AN AGREEMENT BETWEEN  
SUPERIOR TOWNSHIP AND THE WASHTENAW COUNTY ROAD  
COMMISSION  
FOR 2018 ROAD IMPROVEMENTS**

**Resolution Number: 2018-14**

**Date: June 18, 2018**

**THIS AGREEMENT** made and entered into this \_\_\_\_\_ day of \_\_\_\_\_, 2018 by and between the Board of Superior Charter Township (the “township”) and the Board of Washtenaw County Road Commissioners (the “road commission”).

**WHEREAS**, both parties desire improvements of local roads located within Superior Township; and

**CHARTER TOWNSHIP OF SUPERIOR BOARD  
REGULAR MEETING  
JUNE 18, 2018  
PROPOSED MINUTES  
PAGE 8**

**WHEREAS**, included within their 2018 Annual Meeting report, the road commission has provided the township with a list of proposed road improvement; and

**WHEREAS**, the township has historically contributed funds to the road commission for improvement of the local roads; and

**THEREFORE, BE IT AGREED** that the township approves the road commission to complete following road improvement projects in 2018:

1. Panama Ct. (CDBG)	\$23,400.00
2. Warren from Napier to Gotfredson	\$105,800.00
3. Joy Road from Plymouth to Gotfredson	\$37,400.00
4. Township wide limestone 2,000 ton @ \$17.61 per ton	\$36,500.00
5. Vreeland Road from Hickman to Gale	\$26,000.00
	\$229,100.00

Possible options

1. Overbrook Court	\$38,000.00
2. Timberwood Court	\$36,500.00
	\$74,500.00

**NOW, THEREFORE** the township approves the Superior Township Supervisor to sign the necessary agreements and the funds for the road improvements will be debited from G.L. 466-866.

**CERTIFICATION STATEMENT**

I, Lynette Findley, the duly qualified Clerk of the Charter Township of Superior, Washtenaw County, Michigan, do hereby certify that the foregoing is a true and correct copy of a resolution adopted at a regular meeting of the Superior Charter Township Board held on June 18, 2018 and that public notices of said meeting were given pursuant to Act No. 267, Public Acts of Michigan, 1976, as amended.

\_\_\_\_\_  
Lynette Findley, Township Clerk

\_\_\_\_\_  
Date Certified

Roll call:

Ayes: McKinney, Findley, Lewis, Williams, Caviston, Green, Schwartz

Nays: None

The motion carried by unanimous vote.

**CHARTER TOWNSHIP OF SUPERIOR BOARD  
REGULAR MEETING  
JUNE 18, 2018  
PROPOSED MINUTES  
PAGE 9**

**C. RESOLUTION 2018-15, TO APPROVE CARLISLE|WORTMAN ASSOCIATES, INC. (CWA) PROFESSIONAL PLANNERS**

It was moved by Caviston, supported by McKinney, to approve Carlisle | Wortman Associates, Inc. (CWA) as the township's new planners.

**CHARTER TOWNSHIP OF SUPERIOR  
BOARD OF TRUSTEES**

**A RESOLUTION APPROVING PLANNING CONTRACT WITH CARLISLE  
WORTMAN ASSOCIATES**

**Resolution Number: 2018-15**

**Date: June 18, 2018**

**WHEREAS**, The Charter Township of Superior Board of Trustees, the planning commission and the zoning and building staff requires the services of a certified and qualified Michigan planner to assist with the development of master plans, zoning ordinances and amendments, plan review and other related services, and;

**WHEREAS**, The Superior Township staff and planning commission has decided that it is in the best interest of the township to hire a new planning consultant for the above services.

**NOW THEREFORE, BE IT RESOLVED** that the Superior Township Board of Trustees hereby approves a contract for planning services between Carlisle Wortman Associates and Superior Township.

**CERTIFICATION STATEMENT**

I, Lynette Findley, the duly qualified Clerk of the Charter Township of Superior, Washtenaw County, Michigan, do hereby certify that the foregoing is a true and correct copy of a resolution adopted at a regular meeting of the Superior Charter Township Board held on June 18, 2018 and that public notices of said meeting were given pursuant to Act No. 267, Public Acts of Michigan, 1976, as amended.

---

Lynette Findley, Township Clerk

---

Date Certified

**CHARTER TOWNSHIP OF SUPERIOR BOARD  
REGULAR MEETING  
JUNE 18, 2018  
PROPOSED MINUTES  
PAGE 10**

Roll call:

Ayes: Caviston, Williams, Green, Lewis, Schwartz, McKinney, Findley

Nays: None

The motion carried by unanimous vote.

**D. RESOLUTION 2018-16, TO APPROVE PURCHASE OF NEW VEHICLE FOR BUILDING DEPARTMENT**

The building department would like to purchase a new vehicle under the State of Michigan MIDEal program with a cost not to exceed \$32,555.00.

It was moved by Lewis, supported by Green, to approve the purchase of a new vehicle for the building department.

**CHARTER TOWNSHIP OF SUPERIOR  
BOARD OF TRUSTEES**

**A RESOLUTION TO APPROVE THE PURCHASE OF  
NEW VEHICLE FOR BUILDING DEPARTMENT**

**Resolution Number: 2018-16**

**Date: June 18, 2018**

**WHEREAS**, The Charter Township of Superior is in need of a vehicle to accommodate the various responsibilities within the township that require transportation; and,

**WHEREAS**, The Charter Township of Superior Building Department Director has received a quote from Gorno Ford, under the State of Michigan MIDEal program, to purchase a 2018 Ford Explorer 4WD; and,

**WHEREAS**, the base price plus recommended options totals \$28,555.00; and,

**WHEREAS**, several other safety options such as BLIS (Blind Spot Information System) with Cross-traffic Alert and Forward Collision Warning with Brake Support may be considered and should not exceed an additional \$4000.00.

**NOW THEREFORE, BE IT RESOLVED** that the Superior Township Board of Trustees hereby approves the purchase of a 2018 Ford Explorer 4WD not to exceed the cost of \$32,555.00.

**CHARTER TOWNSHIP OF SUPERIOR BOARD  
REGULAR MEETING  
JUNE 18, 2018  
PROPOSED MINUTES  
PAGE 11**

**CERTIFICATION STATEMENT**

I, Lynette Findley, the duly qualified Clerk of the Charter Township of Superior, Washtenaw County, Michigan, do hereby certify that the foregoing is a true and correct copy of a resolution adopted at a regular meeting of the Superior Charter Township Board held on June 18, 2018 and that public notices of said meeting were given pursuant to Act No. 267, Public Acts of Michigan, 1976, as amended.

\_\_\_\_\_  
Lynette Findley, Township Clerk

\_\_\_\_\_  
Date Certified

Roll call:

Ayes: Lewis, Williams, Green, Caviston, Findley, McKinney, Schwartz

Nays: None

The motion carried by unanimous vote.

**E. MOTION TO APPROVE CONTRACT FROM G&K FLOORING FOR SUPERIOR TOWNSHIP HALL**

The tiles in the vestibule of the township hall need to be replaced due to neglect. The cost for the replacement is \$6125.00.

It was moved by McKinney, supported by Green, to approve the contract from G&K flooring for Superior Township Hall.

The motion carried by unanimous vote.

**12. BILLS for PAYMENT and RECORD of DISBURSEMENTS**

It was moved by McKinney, supported by Caviston, to receive bills for payment and record of disbursements in the amount of \$1,787,115.89.

The motion carried by unanimous vote.

**13. PLEAS and PETITIONS**

- Trustee Williams brought up the concern that the signs leading into the township are in poor shape. Supervisor Schwartz stated that an order has been placed with the sign shop to have the signs replaced. The Washtenaw County Road Commission will cover the cost.
- Ellen Kurath discussed the invasiveness of honeysuckle growing in the township.
- Juan Bradford, Parks & Recreation administrator, told the board that the Parks & Recreation Summer Playground Program began today.

**CHARTER TOWNSHIP OF SUPERIOR BOARD  
REGULAR MEETING  
JUNE 18, 2018  
PROPOSED MINUTES  
PAGE 12**

**14. ADJOURNMENT**

The meeting adjourned at 8:35 p.m.

Respectfully submitted,

Lynette Findley, Clerk

Kenneth Schwartz, Supervisor



# Technical memorandum

**Date:** June 29, 2018

**To:** Ken Schwartz, Supervisor & Lynette Findley, Clerk  
Superior Charter Township

**From:** George Tsakoff, PE & Kyle Selter  
OHM Advisors

**Re:** Harvest Lane Sanitary Sewer  
Condition Assessment Summary

The intent of this technical memo is to summarize our process, analysis and recommendation related to the potential sanitary sewer replacement or rehabilitation for the existing sanitary sewer located along Harvest Lane. The sewer pipe is located within the Harvest Lane public road Right-of-way between Bazley Street and MacIntosh Road. As part of this analysis, OHM collected invert data of the existing sanitary sewer, performed utility structure inventories of public utilities, obtained private utility information from MissDigg, established road Right-of-way width along the corridor, conducted field visits, performed basis of design, and identified viable options for sanitary sewer replacement or rehabilitation. We have summarized our findings below.

## **SANITARY SEWER REPLACEMENT & REHABILITATION METHOD OVERVIEW**

### **Background Information**

We understand that the existing sanitary sewer is a 30-inch diameter pipe that is subject to on-going maintenance issues, and is in poor structural condition. Furthermore, the corridor containing the sewer pipe has been prone to developing sinkholes along the route. This usually indicates that there are structural deficiencies in the pipe that are allowing sediment to enter the system, and this condition would be expected to worsen over time. The main objective of this phase of the project was to identify an appropriate sanitary sewer rehabilitation or replacement strategy to prevent additional sinkholes from occurring, and provide a structural solution to the deteriorating pipe condition before it worsens.

The sanitary sewer was televised during the previous SAW study efforts, and defects in the pipe were noted by the pipe-televising contractor, United Resource. After review of the videos and reports, the pipe was found to contain various defects and protrusions such as large root balls, encrustations, and isolated segments of sagging pipe holding sewage. After reviewing survey data, some pipe segments were found to have backfall between manholes. Typically, flat pipe segments or pipe with backfall can be prone to backups over time, however due to the excessive capacity of the existing pipe (based on existing upstream flows), to our knowledge, no back-up related issues have occurred.

The potential rehabilitation or replacement methods for this pipe segment have been identified as Cured-in-Place-Pipe (CIPP) for lining of the existing sanitary sewer, or open cut installation of a new parallel sanitary sewer. CIPP lining is a pipe rehabilitation method that utilizes the existing pipe structure as a form so that the CIPP effectively mimics the slope and diameter of the host pipe. The CIPP material is flexible until cured by pressurized steam or water, and becomes rigid with structural properties thereafter. This method is typically utilized in areas where limiting surface disturbance is advantageous, or in locations that may contain underground conflicts. The second method identified is open cut installation of a new parallel sanitary sewer.



This method of installation is common for underground utilities, especially gravity sanitary sewer with minimal slope. Open excavation of a new sewer pipe would involve an excavated trench with prepared bedding, and is backfilled with specified material.

### **Design Considerations**

As noted above, the two strategies to rehabilitate and replace the sanitary sewer along the Harvest Lane corridor are CIPP lining of the existing 30" pipe, and installation of a new smaller sized parallel sewer along the public road Right-of-way corridor. During review for the viability of these options, we considered items such as method of installation, impact to the existing sewer system, disturbance to the corridor and residents, and construction cost.

Because the existing sanitary sewer does not have capacity issues or major shearing at pipe joints or deformations in the pipe, CIPP is a viable strategy for rehabilitation. From discussions with an industry contractor, locations of sagging in the pipe is acceptable for a CIPP application because there are no capacity issues. Industry experts also report that CIPP may improve some flow aspects of the pipe based on the roughness coefficient of the material when compared to concrete. Should the pipe condition not be acceptable for CIPP installation in isolated locations due to the pipe irregularities mentioned above, those isolated segments could be removed and replaced. The CIPP lining can then be installed along the entire segment. Typically, CIPP lining is installed between manholes that can be used for access points. Once the CIPP lining is cured, it becomes a solid pipe along the length of the segment. In order to provide openings at existing sewer lead locations, a pneumatic robot with a saw blade adaptor will cut through the lining.

Analysis of the Harvest Lane road Right-of-way corridor for existing pavement condition and existing utilities showed that a new parallel sewer was most viable if constructed along the segment southeast of Russet Road, to the downstream connection at MacIntosh Road. The remainder of the existing sanitary sewer to the northwest of Russet Road would be better suited for CIPP lining, to avoid disturbance to the newer road pavement. The alignment of the parallel sewer was determined based on limiting the impact to private properties, road, sidewalk, water main, storm sewer, light poles, and franchise utilities.

The proposed option of new parallel sewer for a portion of the route as shown on the attached figure would require removal of the existing road pavement. Considerations were also made for pipe size and slope. A basis of design for the portion of new parallel sewer was completed and we determined that the parallel sewer is viable with an 8-inch diameter pipe.

### **Installation Considerations for CIPP**

To achieve a successful installation of CIPP lining, the host pipe must be clear of all protrusions, including root balls and encrustations, and cleaned of all debris. The contractor is able to remove root balls and encrustations by use of a mechanical auger and can clean out remaining debris with a water jet assembly. For any pipe protruding into the sewer, a pneumatic driven robot with a saw blade is necessary to cut and remove the pipe. One factor that should be verified during a future design phase is consideration of the water table. If the water table is above the desired CIPP elevation, additional water or steam pressure during installation will be necessary to force the flexible CIPP material to the wall of the existing host pipe, which may increase cost. Because of the relatively shallow depth of the sanitary sewer in this project area, groundwater is not anticipated to be an issue at this time.

Sewer bypass pumping is also necessary to allow the host pipe to remain clear for CIPP installation. By-pass pumping is typically performed from manhole to manhole during the installation, to by-pass the CIPP work area.

CIPP can also be installed without major disturbance to the ground surface because it is a trenchless technology. By utilizing an existing pipe for alignment and slope, no extensive utility conflicts would be anticipated. This method does not typically require removal of driveways or landscaping features unless





required for access pits. Due to existing utilities along the Harvest Lane corridor and relatively high residential density, CIPP is a more cost effective rehabilitation strategy as well.

Although CIPP is a viable option for rehabilitation of the existing sanitary sewer, it does not solve the relatively flat pipe slope or locations of back-slope within the existing system. This was a consideration in evaluating the need for a parallel sewer along the entire route. Although because of the excessive capacity within the existing pipe, and to our knowledge no reported sewer back-ups, CIPP is a cost effective rehabilitation method that would avoid excessive surface disturbance.

To allow the sanitary sewer to function as intended over time, we recommend the Township include the sewer pipe on a regular cleaning schedule for pipe jetting. Jetting the pipe will help prevent build-up of settled debris within the pipe.

### **Other Sanitary Sewer Rehabilitation Options Considered**

Slip lining the existing sanitary sewer with a smaller diameter pipe (most likely a high density polyethylene pipe) was also considered as part of this analysis. However, due to lack of elevation change from the upstream to downstream end of the existing sewer, maintaining a proper slope for the new host pipe was a concern. Furthermore with CIPP being a viable option to allow for a consistent slope through the pipe and for maintenance of sewer lead connections, our opinion is that slip lining of the existing pipe would provide more risk in creating back-fall in the system. A slip-lined pipe would have less capacity to withstand build-up of sediment in the pipe over time.

### **CONSTRUCTION COST SUMMARY**

Based on discussions with industry professionals and historical unit price data, preliminary opinions of probable construction costs for each of the strategies was established and are attached to this memo. The following is a summary of those costs.

1. CIPP Lining of Sanitary Sewer - Estimated Probable Construction Cost: \$815,970
2. CIPP Lining & Parallel Sanitary Sewer - Estimated Probable Construction Cost: \$942,650
3. Parallel Sanitary Sewer with Road Reconstruction - Estimated Probable Construction Cost: \$1,295,200

These costs noted above are only construction related cost estimates, and do not include fees associated with professional engineering services for design or construction administration and engineering. We also assume that if Item 2 above was selected to construct a portion of new parallel sewer south of Russet Road, that the road pavement in that area would also be replaced as part of Item 3.

### **RECOMMENDATION**

Based on the analysis outlined above, OHM Advisors recommends rehabilitating the existing 30-inch diameter sanitary sewer by method of Cured in Place Pipe (CIPP) for the entire route. Based on review of the sanitary sewer televised inspection videos and reports, and correspondence with experienced professionals regarding CIPP, this method of rehabilitation is viable. It would provide a long-term structural rehabilitation of the pipe at the lowest cost impact to the system. Although this method would require increased maintenance along the sewer route due to maintaining an oversized pipe based on existing flows, this installation method would significantly reduce surface impact when compared to constructing a new parallel sewer.

It should also be noted that installing a CIPP liner would allow for individual sanitary sewer leads to be maintained from the interior of the sanitary sewer main line pipe. This is advantageous in terms of minimizing surface impact and sewer service to home owners, although it would not allow for any sewer lead pipe replacement as part of this project.



A separate option that is also viable for this project would be a combination of CIPP lining in the northwest segment of the system located north of Russet Road, and construction of a new 8" parallel sewer in the southeast portion of the system. This option may be worthwhile to consider if road pavement replacement will occur at the time of sanitary sewer construction between Russet Road and MacIntosh Street.

We look forward to discussing our analysis and summary further at the July 16, 2018 Board of Trustees Meeting.

### **ATTACHMENTS**

- A: CIPP Rehabilitation - Preliminary Estimate
- B: CIPP & New Parallel Sanitary Sewer - Preliminary Estimate
- C: Sanitary Sewer Rehabilitation Preliminary Alignment Drawings



ORCHARD, HILTZ & McCLIMENT, INC.  
34000 Plymouth Road, Livonia, Michigan, 48150

CLIENT: Superior Township  
PROJECT: Harvest Lane Sanitary Sewer  
PROJECT DESCRIPTION: Cured in Place Pipe  
\_\_\_\_\_  
\_\_\_\_\_  
\_\_\_\_\_

ENGINEER'S OPINION OF PROBABLE  
CONSTRUCTION COST  
ATTACHMENT A

Telephone: (734) 522-6711 FAX: (734) 522-6427

DATE: Jun 26, 2018  
PROJECT NO. 0140-18-0030  
ESTIMATOR: KMS  
CHECKED BY: \_\_\_\_\_

BASIS FOR ESTIMATE:  CONCEPTUAL  PRELIMINARY  FINAL

Item	Description	Unit	Total Quantity	Unit Price	Total Cost
1	Mobilization, 10% max.	LS	1	\$67,435.50	\$67,435.50
2	Audio Video Route Survey	LS	1	\$2,500.00	\$2,500.00
3	Traffic Control	LS	1	\$15,000.00	\$15,000.00
4	Erosion Control	LS	1	\$2,000.00	\$2,000.00
5	Clearing	LS	1	\$2,000.00	\$2,000.00
6	Driveway, Rem	SYD	50	\$12.00	\$600.00
7	Sanitary Bypass	LS	1	\$25,000.00	\$25,000.00
8	Sewer Televising and Cleaning	FT	2,346	\$2.50	\$5,865.00
9	Sanitary Sewer, Remove and Replace, 30 inch	LF	200	\$325.00	\$65,000.00
10	Sanitary Manhole Rehabilitation	EA	10	\$3,000.00	\$30,000.00
11	Sanitary Sewer Rehabilitation by CIPP (Exist 30" pipe)	LF	2,346	\$215.00	\$504,390.00
12	Service Lead Reconnection, 6" PVC and Smaller	EA	70	\$150.00	\$10,500.00
13	Driveway, Conc	SYD	50	\$70.00	\$3,500.00
14	Restoration	LS	1	\$8,000.00	\$8,000.00

Subtotal \$741,790.50  
Contingency, 10% \$74,179.05

**Total Opinion of Probable Construction Cost \$815,969.55**



ORCHARD, HILTZ & McCLIMENT, INC.  
34000 Plymouth Road, Livonia, Michigan, 48150

CLIENT: Superior Township  
PROJECT: Harvest Lane Sanitary Sewer  
PROJECT DESCRIPTION: Cured in Place Pipe and open cut parallel gravity sanitary sewer

ENGINEER'S OPINION OF PROBABLE  
CONSTRUCTION COST  
ATTACHMENT B

Telephone: (734) 522-6711 FAX: (734) 522-6427

DATE: Jun 26, 2018  
PROJECT NO. 0140-18-0030  
ESTIMATOR: KMS  
CHECKED BY: \_\_\_\_\_

BASIS FOR ESTIMATE: [ ] CONCEPTUAL [X] PRELIMINARY [ ] FINAL

Division I: Sanitary Sewer

Item	Description	Unit	Total Quantity	Unit Price	Total Cost
1	Mobilization, 10% max.	LS	1	\$77,856.00	\$77,856.00
2	Sidewalk, Rem	SYD	30	\$18.00	\$540.00
3	Sanitary Sewer, 8 inch	LF	830	\$225.00	\$186,750.00
4	Sanitary Manhole, 48 inch	EA	4	\$6,500.00	\$26,000.00
5	Sanitary Sewer Tap, 8 inch	EA	2	\$10,000.00	\$20,000.00
6	Sanitary Serv	FT	880	\$80.00	\$70,400.00
7	Sanitary Serv, Connect	EA	26	\$500.00	\$13,000.00
8	Sewer Televising and Cleaning	FT	1,568	\$2.50	\$3,920.00
9	Sanitary Bypass	LS	1	\$20,000.00	\$20,000.00
10	Sanitary Sewer, Remove and Replace, 30 inch	LF	150	\$325.00	\$48,750.00
11	Sanitary Manhole Rehabilitation	EA	7	\$3,000.00	\$21,000.00
12	Sanitary Sewer Rehabilitation by CIPP (Exist 30" pipe)	LF	1,568	\$215.00	\$337,120.00
13	Service Lead Reconnection, 6" PVC and Smaller	EA	44	\$150.00	\$6,600.00
14	Sanitary Manhole, Abandon	EA	3	\$800.00	\$2,400.00
15	Grout in Place Existing Sanitary Sewer, 30 inch	CYD	160	\$130.00	\$20,800.00
16	Sidewalk, 4 inch	SFT	260	\$7.00	\$1,820.00

Subtotal Division I: Sanitary Sewer **\$856,956.00**

Contingency, 10% **\$85,695.60**

Subtotal Division I Opinion of Probable Construction Cost **\$942,651.60**

Division II: Roadway

Item	Description	Unit	Total Quantity	Unit Price	Total Cost
1	Mobilization, 10% max.	LS	1	\$28,910.00	\$28,910.00
2	Audio Video Route Survey	LS	1	\$2,500.00	\$2,500.00
3	Traffic Control	LS	1	\$15,000.00	\$15,000.00
4	Erosion Control	LS	1	\$3,500.00	\$3,500.00
5	Curb & Gutter, Rem	FT	2,050	\$13.00	\$26,650.00
6	Roadway, Rem	SYD	2,850	\$11.00	\$31,350.00
7	Driveway, Rem	SYD	250	\$14.00	\$3,500.00
8	Dr Structure, Rem	EA	2	\$500.00	\$1,000.00
9	Sewer, CI IV, 12 inch	FT	80	\$65.00	\$5,200.00
10	Dr Structure, Rebuild	EA	7	\$2,600.00	\$18,200.00
11	Dr Structure, 24 inch dia	EA	2	\$1,800.00	\$3,600.00
12	Aggregate Base, 8 inch	SYD	3,550	\$12.00	\$42,600.00
13	HMA, 4 inch	TON	650	\$95.00	\$61,750.00
14	Curb & Gutter, Det F4	FT	2,050	\$25.00	\$51,250.00
15	Driveway, Approach	SYD	250	\$70.00	\$17,500.00
16	Restoration	LS	1	\$8,000.00	\$8,000.00

Subtotal Division II: Roadway **\$320,510.00**

Contingency, 10% **\$32,051.00**

Subtotal Division II Opinion of Probable Construction Cost **\$352,561.00**

Total Opinion of Probable Construction Cost **\$1,295,212.60**

**From:** Craig Aronoff [<mailto:craig@cannabislegalgroup.com>]

**Sent:** Thursday, July 05, 2018 4:29 PM

**To:** Ken Schwartz <[kenschwartz@superior-twp.org](mailto:kenschwartz@superior-twp.org)>; Lynette Findley <[lynettefindley@superior-twp.org](mailto:lynettefindley@superior-twp.org)>

**Cc:** Craig Aronoff <[craig@cannabislegalgroup.com](mailto:craig@cannabislegalgroup.com)>

**Subject:** MMFLA

Ken

Good afternoon. I hope you had a nice holiday. Are you at liberty to share with me the results of your recent survey as it relates to the new medical marijuana laws?

I would also request an opportunity to be added to your agenda formerly so we can provide additional information on the law from the industry rather than just the township attorney. At the workshop, several of the residents seemed to desire and request an opportunity to learn more and I'd appreciate the chance to accommodate them.

Thank you for your consideration. I look forward to your reply.

Craig



**Craig A. Aronoff, Esq.**  
Attorney and Counselor



**CANNABIS**  
LEGAL GROUP

**Office:** (248) 541-2600

**Facsimile:** (855) 541-2600

520 N Main Street

Royal Oak, MI 48067

[craig@cannabislegalgroup.com](mailto:craig@cannabislegalgroup.com)

[cannabislegalgroup.com](http://cannabislegalgroup.com)

**SUPERIOR TOWNSHIP BUILDING DEPARTMENT**  
**MONTH-END REPORT**  
**June 2018**

Category	Estimated Cost	Permit Fee	Number of Permits
<b>Com/Multi-Family Renovations</b>	<i>\$303,580.00</i>	<i>\$2,173.00</i>	<i>2</i>
<b>Com-Other Non-Building</b>	<i>\$10,000.00</i>	<i>\$200.00</i>	<i>1</i>
<b>Electrical Permits</b>	<i>\$0.00</i>	<i>\$2,819.00</i>	<i>18</i>
<b>Mechanical Permits</b>	<i>\$0.00</i>	<i>\$4,469.00</i>	<i>33</i>
<b>Plumbing</b>	<i>\$0.00</i>	<i>\$3,213.00</i>	<i>18</i>
<b>Res-Additions (Inc. Garages)</b>	<i>\$136,435.00</i>	<i>\$981.00</i>	<i>3</i>
<b>Res-Manufactured/Modular</b>	<i>\$500,000.00</i>	<i>\$1,500.00</i>	<i>10</i>
<b>Res-New Building</b>	<i>\$1,236,362.00</i>	<i>\$8,186.00</i>	<i>3</i>
<b>Res-Other Building</b>	<i>\$132,512.00</i>	<i>\$550.00</i>	<i>5</i>
<b>Res-Other Non-Building</b>	<i>\$20,000.00</i>	<i>\$100.00</i>	<i>1</i>
<b>Res-Renovations</b>	<i>\$102,500.00</i>	<i>\$735.00</i>	<i>2</i>
<b>Totals</b>	<b><i>\$2,441,389.00</i></b>	<b><i>\$24,926.00</i></b>	<b><i>96</i></b>

SUPERIOR TOWNSHIP BUILDING DEPARTMENT  
YEAR-TO-DATE REPORT

January 2018 To Date

Category	Estimated Cost	Permit Fee	Number of Permits
<b>Com/Multi-Family Other Building</b>	<i>\$106,391.00</i>	<i>\$495.00</i>	<i>3</i>
<b>Com/Multi-Family Renovations</b>	<i>\$2,260,512.00</i>	<i>\$10,315.00</i>	<i>8</i>
<b>Com-Other Non-Building</b>	<i>\$45,690.00</i>	<i>\$850.00</i>	<i>5</i>
<b>Electrical Permits</b>	<i>\$0.00</i>	<i>\$25,729.00</i>	<i>152</i>
<b>Mechanical Permits</b>	<i>\$0.00</i>	<i>\$31,842.55</i>	<i>198</i>
<b>Plumbing</b>	<i>\$0.00</i>	<i>\$17,429.00</i>	<i>126</i>
<b>Res-Additions (Inc. Garages)</b>	<i>\$504,170.00</i>	<i>\$3,406.00</i>	<i>10</i>
<b>Res-Manufactured/Modular</b>	<i>\$2,480,000.00</i>	<i>\$7,750.00</i>	<i>52</i>
<b>Res-New Building</b>	<i>\$5,477,397.00</i>	<i>\$33,804.00</i>	<i>19</i>
<b>Res-Other Building</b>	<i>\$361,140.00</i>	<i>\$2,950.00</i>	<i>29</i>
<b>Res-Other Non-Building</b>	<i>\$211,271.00</i>	<i>\$1,266.00</i>	<i>10</i>
<b>Res-Renovations</b>	<i>\$328,820.00</i>	<i>\$1,998.00</i>	<i>7</i>
<b>Totals</b>	<b><i>\$11,775,391.00</i></b>	<b><i>\$137,834.55</i></b>	<b><i>619</i></b>

# SUPERIOR TOWNSHIP FIRE DEPARTMENT

## MEMO

**To:** Ken Schwartz, Lynette Findley, Brenda McKinney  
**CC:** Paula Jefferson  
**From:** Vic Chevrette, Fire Chief  
**Date:** 7/10/2018  
**Re:** Fire Chief Activity Report June 2018

---

The following is the June 2018 activity report for the Fire Chief.

Fire Suppression Plan Reviews: 1

Fire Suppression Inspections: 3

Fire Protection Inspections: 1

Building Plan Review: 2

Site Plan Review: 3

Pre-construction meeting: 0

Consultation, Fire Protection: 1

Fire Alarm Plan Review: 0

Fire Alarm Test: 0

Fire Investigations: 0

Fire Code Enforcement: 0

Burn Permits issued: 2

Meetings Attended: WAMAA Fire Chiefs, Washtenaw County EOC, St. Joseph Mercy Hospital Evacuation Plan.

Training: ESO Firehouse software (Toledo, OH), Huron Valley Code Officials, ATV.

Other: Hazmat response, Karl's Cabin 6008 Gotfredson Road, Salem Twp., Motel 6 3764 S. State St. Pittsfield Twp.

Respectfully Submitted

Victor G. Chevrette, Fire Chief



JUNE 2018

**TO: KEN SCHWARTZ SUPERVISOR**

**FROM: SHAUN BACH - CAPTAIN**

**SUBJECT: HOSPITAL ALARMS**

**DATE: 7-3-2018**

**SUPERIOR TOWNSHIP FIRE DEPARTMENT FALSE ALARM RESPONSES TO  
SAINT JOSEPH HOSPITAL**

**TOTAL FALSE ALARMS:**

**1ST. ALARM: NO CHARGE**

**2<sup>ND</sup> ALARM \$50.00**

**3<sup>RD</sup> ALARM \$200.00**

**TOTAL: \$.00**

**ALARM LOCATIONS:**

6-12-2018 5401 MCAULEY

SUPERIOR

Incident List by Street Address

Alarm Date Between {06/01/2018} And {06/30/2018}  
and FDID = "08111" and Incident Type Between  
"322" And "323"

Incident-Exp#	Alm Date	Alm Time	Location	Incident Type
18-0815654-000	06/06/2018	08:53:00	On west bound M4 East of	322 Motor vehicle accident with
18-0816121-000	06/11/2018	13:23:00	Dixboro Rd West of Dixbor	323 Motor vehicle/pedestrian acc
18-0816406-000	06/14/2018	08:33:00	528 E CLARK RD	322 Motor vehicle accident with

Total Incident Count 3

SUPERIOR

Incident List by Street Address

Alarm Date Between {06/01/2018} And {06/30/2018}  
and Incident Type Between "700" And "746"

Incident-Exp#	Alm Date	Alm Time	Location	Incident Type
18-0815953-000	06/09/2018	13:32:00	5551 GREAT HAWK CIR	744 Detector activation, no fire
18-0816682-000	06/17/2018	10:53:00	9062 MACARTHUR BLVD	700 False alarm or false call, C
18-0816262-000	06/12/2018	19:44:00	5401 MCAULEY DR	700 False alarm or false call, C

Total Incident Count 3

SUPERIOR

Incident Type Report (Summary)

Alarm Date Between {06/01/2018} And {06/30/2018}  
and FDID = "08111"

Incident Type	Count	Pct of Incidents	Total Est Loss	Pct of Losses
<b>1 Fire</b>				
111 Building fire	1	1.26%	\$0	0.00%
	1	1.26%	\$0	0.00%
<b>3 Rescue &amp; Emergency Medical Service Incident</b>				
311 Medical assist, assist EMS crew	22	27.84%	\$0	0.00%
321 EMS call, excluding vehicle accident with	17	21.51%	\$0	0.00%
322 Motor vehicle accident with injuries	2	2.53%	\$0	0.00%
323 Motor vehicle/pedestrian accident (M/Ped)	1	1.26%	\$0	0.00%
324 Motor Vehicle Accident with no injuries	3	3.79%	\$0	0.00%
	45	56.96%	\$0	0.00%
<b>4 Hazardous Condition (No Fire)</b>				
421 Chemical hazard (no spill or leak)	1	1.26%	\$0	0.00%
422 Chemical spill or leak	1	1.26%	\$0	0.00%
424 Carbon monoxide incident	1	1.26%	\$0	0.00%
440 Electrical wiring/equipment problem Other	3	3.79%	\$0	0.00%
442 Overheated motor	1	1.26%	\$0	0.00%
451 Biological hazard, confirmed or suspected	1	1.26%	\$0	0.00%
	8	10.12%	\$0	0.00%
<b>5 Service Call</b>				
510 Person in distress, Other	1	1.26%	\$0	0.00%
550 Public service assistance, Other	2	2.53%	\$0	0.00%
554 Assist invalid	2	2.53%	\$0	0.00%
	5	6.32%	\$0	0.00%
<b>6 Good Intent Call</b>				
600 Good intent call, Other	1	1.26%	\$0	0.00%
611 Dispatched & cancelled en route	13	16.45%	\$0	0.00%
631 Authorized controlled burning	1	1.26%	\$0	0.00%
650 Steam Other gas mistaken for smoke, Other	1	1.26%	\$0	0.00%
	16	20.25%	\$0	0.00%
<b>7 False Alarm &amp; False Call</b>				
700 False alarm or false call, Other	2	2.53%	\$0	0.00%

SUPERIOR

Incident Type Report (Summary)

Alarm Date Between {06/01/2018} And {06/30/2018}  
and FDID = "08111"

Incident Type	Count	Pct of Incidents	Total Est Loss	Pct of Losses
<b>7 False Alarm &amp; False Call</b>				
744 Detector activation, no fire -	1	1.26%	\$0	0.00%
	<u>3</u>	<u>3.79%</u>	<u>\$0</u>	<u>0.00%</u>
<b>8 Severe Weather &amp; Natural Disaster</b>				
814 Lightning strike (no fire)	1	1.26%	\$0	0.00%
	<u>1</u>	<u>1.26%</u>	<u>\$0</u>	<u>0.00%</u>

Total Incident Count: 79

Total Est Loss: \$0

SUPERIOR

Aid Responses by Incident

Alarm Date Between {06/01/2018} And {06/30/2018}

Department	Notified	Aid Type	Fire	EMS	Resc	Other
18-0816121 06/11/2018 13:23:00						
323 Motor vehicle/pedestrian accident (MV Ped)						
Dixboro Rd West of Dixboro Dam, Rail Rd marker 34/Ann Arbor, MI 48105						
AATW Ann Arbor	06/ 11/ 2018	4 Automatic aid	#Personnel	0	4	0
Township		given	#Apparatus	0	4	0
Response Time: 00:05:00						

Subtotal Responses: 1 Average Aid Response Time for Incident: 00:05:00

18-0816176 06/11/2018 21:15:56						
650 Steam, Other gas mistaken for smoke, Other						
0 EMU /Bruce T hall library						
YPSI CI TY Ypsilanti	06/ 11/ 2018	4 Automatic aid	#Personnel	0	0	0
City Fire Department		given	#Apparatus	0	0	0
Response Time: 00:05:38						

Subtotal Responses: 1 Average Aid Response Time for Incident: 00:05:38

18-0816208 06/12/2018 08:59:00						
440 Electrical wiring/equipment problem, Other						
757 Mildred ST						
YPSI CI TY Ypsilanti	06/ 12/ 2018	4 Automatic aid	#Personnel	3	0	0
City Fire Department		given	#Apparatus	2	0	0
Response Time: 00:06:00						

Subtotal Responses: 1 Average Aid Response Time for Incident: 00:06:00

18-0816351 06/13/2018 15:39:00						
111 Building fire						
7374 Chubb /Plymouth, MI 48170						
SALEM Sal em Township	06/ 13/ 2018	3 Mutual aid given	#Personnel	0	0	0
Fire Department			#Apparatus	0	0	0
Response Time: 00:10:00						

Subtotal Responses: 1 Average Aid Response Time for Incident: 00:10:00

Response time calculated from time notified to arrival time.

SUPERIOR

Aid Responses by Incident

Alarm Date Between {06/01/2018} And {06/30/2018}

Department	Notified	Aid Type	Fire	EMS	Resc	Other
18-0816406 06/14/2018 08:33:00						
322 Motor vehicle accident with injuries						
528 E CLARK RD						
YPSI TWP Ypsilanti	06/14/2018	3 Mutual aid given	#Personnel	0	0	0
Township Fire			#Apparatus	0	0	0
Department						
Response Time: 00:06:00						
Subtotal Responses: 1			Average Aid Response Time for Incident: 00:06:00			

18-0816899 06/19/2018 10:01:00						
422 Chemical spill or leak						
6005 GOTFREDSON RD /Plymouth, MI 48170						
SALEM Salem Township	06/19/2018	3 Mutual aid given	#Personnel	0	0	0
Fire Department			#Apparatus	0	0	0
Their Inci 264						
Response Time: 00:14:00						
Subtotal Responses: 1			Average Aid Response Time for Incident: 00:14:00			

18-0817940 06/30/2018 14:26:00						
440 Electrical wiring/equipment problem, Other						
452 Ainsworth CI						
YPSI CITY Ypsilanti	06/30/2018	4 Automatic aid	#Personnel	3	0	0
City Fire Department		given	#Apparatus	2	0	0
Response Time: 00:09:00						
Subtotal Responses: 1			Average Aid Response Time for Incident: 00:09:00			

18-0817943 06/30/2018 14:20:00						
451 Biological hazard, confirmed or suspected						
3764 S State ST /Ann Arbor, MI 48104						
PI TTSFI ELD Pittsfield	06/30/2018	5 Other aid given	#Personnel	0	0	0
Township Fire			#Apparatus	0	0	1
Department						
Response Time: 00:19:00						

Response time calculated from time notified to arrival time.

SUPERIOR

Aid Responses by Incident

Alarm Date Between {06/01/2018} And {06/30/2018}

Department	Notified	Aid Type	Fire	EMS	Resc	Other
18-0817943	06/30/2018 14:20:00					
451 Biological hazard, confirmed or suspected						
3764 S State ST /Ann Arbor, MI 48104						
Subtotal Responses: 1			Average Aid Response Time for Incident: 00:19:00			

Response time calculated from time notified to arrival time.



SUPERIOR

Incident List by Street Address

Alarm Date Between {06/01/2018} And {06/30/2018}  
and Incident Type Between "100" And "123"

---

Incident-Exp#	Alm Date	Alm Time	Location	Incident Type
18-0816351-000	06/13/2018	15:39:00	7374 Chubb / Plymouth, M	111 Building fire

---

Total Incident Count      1

# **Superior Township Monthly Report**

## **May/ June 2018**

### **Resident Debris/ Complaints:**

1690 Stephens - Boat on neighbor's property - **(Office Notified)**  
1630 Wiard Rd. - Debris on Extension - **(Tagged for Removal)**  
1845 Wexford - Debris on Extension - **(Tagged for Removal)**  
1654 Wiard - Refuse on Extension - **(Tagged for Removal)**  
1723 Savannah - T.V. on Extension - **(Tagged for Removal)**  
8728 Barrington - Chairs on Extension - **(Tagged for Removal)**  
1751 Savannah - Recycling Container on Extension - **(Tagged for Removal)**  
1785 Savannah - Carpet Rolls on Extension - **(Tagged for Removal)**  
8607 Somerset - Sofa on Extension - **(Tagged for Removal)**  
5045 Plymouth - Sofa & Container on Extension - **(Tagged)**  
8605 Nottingham - Metal Pieces on Extension - **(Tagged for Removal)**  
4899 Napier Rd. - Sofa on Extension - **(Tagged for Removal)**  
8623 Cedar Ct. - Large logs blocking walkway - **(Owner Notified)**  
1661 Savannah - Carpet Rolls on Extension - **(Tagged for Removal)**  
1702 Savannah - Chair on Extension - **(Tagged for Removal)**  
1769 Savannah - Chair on Extension - **(Tagged for Removal)**  
8282 Warwick Ct. - Chair on Extension - **(Tagged for Removal)**  
1700 Bridgewater - Toilet on Extension - **(Tagged for Removal)**  
8491 Berkshire - 2 Chairs on Extension - **(Tagged for Removal)**  
1167 Stamford Rd. - Table & Misc. on Extension - **(Tagged for Removal)**

### **Yard Waste & Grass:**

9661 Wexford - Grass - **(Tagged To Be Cut)**  
9759 Ravenshire - Grass - **(Tagged To Be Cut)**  
9843 High Meadow - Grass - **(Tagged To Be Cut)**  
9730 Ravenshire - Grass - **(Tagged To Be Cut)**  
1823 Ashley Dr. - Grass - **(Tagged To Be Cut)**  
1811 Ashley Dr. - Grass - **(Tagged To Be Cut)**  
9258 Abbey - Grass - **(Tagged To Be Cut)**  
9201 Arlington - Grass - **(Tagged To Be Cut)**  
8642 Cedar Ct. - Grass - **(Tagged To Be Cut)**  
3688 Heather Ct. - Grass - **(Tagged To Be Cut)**  
1833 Savannah - Grass - **(Tagged To Be Cut)**

8831 Somerset - Grass - **(Tagged To Be Cut)**  
1762 Sheffield - Grass - **(Tagged To Be Cut)**  
7949 Hallie - Grass - **(Tagged To Be Cut)**  
1669 Savannah - Grass - **(Tagged To Be Cut)**  
9654 Wexford - Grass - **(Tagged To Be Cut)**  
9655 Wexford - Grass - **(Tagged To Be Cut)**  
9761 Ravenshire - Grass - **(Tagged To Be Cut)**  
1989 Andover - Grass - **(Tagged To Be Cut)**  
1618 Stephens Dr. - Grass - **(Tagged To Be Cut)**  
8768 Nottingham Dr. - Grass - **(Tagged To Be Cut)**  
8760 Nottingham Dr. - Grass - **(Tagged To Be Cut)**  
1619 McArthur Dr. - Grass - **(Tagged To Be Cut)**  
8975 Nottingham Dr. - Grass - **(Tagged To Be Cut)**  
9288 Panama Ave. - Grass - **(Tagged To Be Cut)**  
1661 Harvest Ln. - Grass - **(Tagged To Be Cut)**  
1657 Harvest Ln. - Grass - **(Tagged To Be Cut)**  
1666 Wiard Rd. - Grass - **(Tagged To Be Cut)**  
1654 Wiard Rd. - Grass - **(Tagged To Be Cut)**  
1658 Wiard Rd. - Grass - **(Tagged To Be Cut)**  
955 E. Clark Rd. - Grass - **(Tagged To Be Cut)**  
1099 Stamford Rd. - Grass - **(Tagged To Be Cut)**  
981 Stamford Rd. - Grass - **(Tagged To Be Cut)**  
8736 Nottingham - Grass - **(Tagged To Be Cut)**  
8744 Nottingham - Grass - **(Tagged To Be Cut)**  
8891 Nottingham - Grass - **(Tagged To Be Cut)**  
8964 Nottingham - Grass - **(Tagged To Be Cut)**  
1717 Dover Ct. - Grass - **(Tagged To Be Cut)**  
1709 Dover Ct. - Grass - **(Tagged To Be Cut)**  
9216 Panama Ave. - Grass - **(Tagged To Be Cut)**  
9272 Panama - Grass - **(Tagged To Be Cut)**  
1575 Harvest Ln. - Grass - **(Tagged To Be Cut)**  
1526 Wiard Rd. - Grass - **(Tagged To Be Cut)**  
1530 Wiard Rd. - Grass - **(Tagged To Be Cut)**  
1520 Wiard Rd. - Grass - **(Tagged To Be Cut)**  
158 Wiard Rd. - Grass - **(Tagged To Be Cut)**  
1821 Stephens Dr. - Brush on extension - **(Tagged To Be Removed)**  
8684 Heather Ct. - Grass - **(Tagged To Be Cut)**

### **Vehicle Complaints:**

8568 Barrington - Vehicle blocking walkway - **(Tagged)**

9866 High Meadow - Boat in driveway - **(Tagged)**

8559 Barrington - Vehicle & Trailer blocking walkway - **(Tagged)**

Harris Rd. & Geddes - Abandoned vehicle - **(Sheriff Tagged)**

### **Illegal Dumpings:**

Harris Rd & Geddes - Mattresses Dumped - **(Office Notified)**

Laforge Rd. & Vreeland Rd. - Sofa Dumped - **(Office Notified)**

Barry Rd & Ford Rd. - 4 Mattresses dumped - **(Office Notified)**

### **Dog Complaint:**

1930 Savannah - Dog poop being left on deck, smells - **(Tagged)**

**CHARTER TOWNSHIP OF SUPERIOR PARKS & RECREATION COMMISSION  
REGULAR MEETING  
JUNE 25, 2018  
PROPOSED MINUTES  
PAGE 1**

**1. CALL TO ORDER**

The regular meeting of the Charter Township of Superior Parks & Recreation Commission was called to order by the Chair Marion Morris at 6:35 p.m. June 25, 2018 at the Old Township Hall, 3040 North Prospect, Superior Township, Michigan.

**2. PLEDGE OF ALLEGIANCE**

Chair Morris led the assembly in the pledge of allegiance to the flag.

**3. ROLL CALL**

The members present were Terry Lee Lansing, Sandi Lopez, Marion Morris, Nahid Sanii-Yahyai, Bernedia Word and Paula Jefferson.

Absent: Martha Kern-Boprie

Others present: Trustee Alex Williams; Juan Bradford, Park Administrator; Dave Buterbaugh, Maintenance Supervisor; Patrick Pigott, Recreation Coordinator

**4. ADOPTION OF AGENDA**

It was moved by Sanii-Yahyai, supported by Lopez, to adopt the agenda as presented.

The motion carried by unanimous vote.

**5. APPROVAL OF MINUTES**

**A. REGULAR MEETING OF MAY 29, 2018**

It was moved by Lopez, supported by Sanii-Yahyai, to approve the minutes of the regular board meeting of May 29, 2018.

The motion carried by unanimous vote.

**6. CITIZEN PARTICIPATION**

None

**7. REPORTS**

**CHARTER TOWNSHIP OF SUPERIOR PARKS & RECREATION COMMISSION**  
**REGULAR MEETING**  
**JUNE 25, 2018**  
**PROPOSED MINUTES**  
**PAGE 2**

**A. CHAIRPERSON**

- Chair Morris will be conducting the annual review for administrator Juan Bradford in the coming month.

**B. ADMINISTRATOR**

Commission Lansing inquired if we have provided porta-johns in the past for the Oakbrook Sports program. Administrator Bradford stated that we had not. He stated that we are providing the porta-johns this year because, in the past, a family who lived near the baseball diamond would let people use their bathroom. The family has since moved away. The cost of two porta-Johns is \$115.00 for two months at a total of \$230.00. We will pay for a third month, but that would be paid for out of the recreation fund as the porta-john will be used for movie night as well.

**C. BOARD LIASON**

- The township was awarded \$10,000.00 from Community Tourism Action Plan (CTAP) for the Dixboro Village Green pavilion.
- Utilizing Right-of-Way Monies, Lucas Nursery will be installing 16 pear trees in the right-of-way on Geddes from Andover to Harris. The total cost will be around \$2500.00.
- No update on Salem Township's Gotfredson sewer plans.
- The Dixboro House (formerly the Lord Fox) plans have been approved by the township.
- Discussions continue regarding the removal of the Peninsular Dam. The township has about 7 residents who have houses behind the dam and hold riparian rights on the pond. They are adamantly opposed to the removal of the dam. The dam is owned by the City of Ypsilanti and the township does not have a say in what happens to the dam. The City of Ypsilanti has funding for removal of the dam not for repair. The township is working to ensure that the residents do not lose their riparian rights.
- The administrative staff met with Ypsilanti District Library (YDL) and the library's architects regarding the plans for the Superior Township branch of the Ypsilanti District Library. If the library millage passes in November the YDL is committing all of its reserves to the new library. The funds generated by the millage would go towards operations for the future. The library design allows for expansion if space is needed in the future.
- There was a 2<sup>nd</sup> reading and adoption of the Fleming Creek Zoning Ordinance Text Amendment. The ordinance amendment will require that commercial developments and subdivisions submit, as part of their site plan, technical information to the Fleming Creek Advisory Council for review and an advisory opinion. The review and opinion are non-binding.

**CHARTER TOWNSHIP OF SUPERIOR PARKS & RECREATION COMMISSION  
REGULAR MEETING  
JUNE 25, 2018  
PROPOSED MINUTES  
PAGE 3**

- There was a 2<sup>nd</sup> reading and adoption for the amendment of Utility Ordinance No. 169. The amendment makes it explicitly clear that the township prohibits private parties or other entities from running water or sewage lines in all road right-of-ways within the township that will serve areas outside the township without authorization from the township.
- The board authorized that July is Parks & Recreation Month.
- There was a second agreement made between the township and the Washtenaw County Road Commission for 2018 road repairs. There is still a question if the sewer lines on Harvest Lane need to be replaced. Once an outcome is determined Harvest Lane will be resurfaced.
- The township has switched planning firms from Pennington to Carlisle | Wortman.
- The building department will be purchasing a new vehicle.
- The board approved the replacement of tiles in the township hall.

**D. BOARD MEETING ATTENDEE**

Commissioner Sanii-Yahyai mentioned a compliment from a citizen regarding the improvement of the roads. He also recommended seasonal weight restrictions for trucks driving on the township roads in order to maintain them longer.

**E. PARK STEWARD**

The Park Steward report was submitted and included info on the variety of ticks in the region.

**F. SAFETY**

None

**8. COMMUNICATIONS**

- A) Educational Info: Year of the Tick
- B) Citizens Letter Requesting Porta-john @ Oakbrook Park
- C) Superior Land Preservation Society Newsletter
- D) Letter of Support for Washtenaw County Parks Skate Park Grant Application
- E) Park Rental Form –Oakbrook Park

It was moved by Sanii-Yahyai, supported by Lansing, to receive the communications.

**CHARTER TOWNSHIP OF SUPERIOR PARKS & RECREATION COMMISSION  
REGULAR MEETING  
JUNE 25, 2018  
PROPOSED MINUTES  
PAGE 4**

**9. OLD BUSINESS**

- Chair Morris thanked everyone who assisted with Superior Day. Attendees had a good time despite the rain. There was a compliment from a Tanglewood resident and they said they would tell their neighbors how much they enjoyed the event.
- Commissioner Sanii-Yahyai inquired about the purpose of a rain date for events. Chair Morris said that the decision to call the event due to rain was not made in time to contact all the vendors who were participating.

**10. NEW BUSINESS**

**A. RESOLUTION PROCLAIMING JULY AS PARKS & RECREATION MONTH**

This is an annual resolution that recognizes July as Parks & Recreation Month. There was some discussion as to the purpose of the annual proclamation.

It was moved by Jefferson, supported by Sanii-Yahyai, to recognize July as Parks & Recreation Month.

The motion carried by unanimous vote.

**B. NEW PARK MAINTENANCE TRUCK BIDS FROM STATE OF MICHIGAN MIDEAL**

It was moved by Sanii-Yahyai, supported by Morris, to accept the MiDeal bid for the purchase of an F-250 Truck from Gorno Ford for the total of \$24,198.00.

Roll call:

Ayes: Word, Morris, Lopez, Lansing, Sanii-Yahyai, Jefferson

Nays: None

Absent: Kern-Boprie

The motion carried by unanimous vote.

**C. SPECIAL EVENTS SIGN-UP**

Kite and Rocket Day: Sanii-Yahyai, Morris, Lopez

Movies in the Park: Everyone

Kickball Day: Jefferson, Sanii-Yahyai, Kern-Boprie?

Dixboro Farmer's Market, Friday, July 27: Word

Dixboro Farmer's Market, Friday, August 31: Morris

Dixboro Farmer's Market, Friday, September 28: Lansing



**CHARTER TOWNSHIP OF SUPERIOR PARKS & RECREATION COMMISSION  
REGULAR MEETING  
JUNE 25, 2018  
PROPOSED MINUTES  
PAGE 5**

**11. BILLS for PAYMENT**

It was moved by Morris, supported by Lansing, to receive the bills for payment in the amount of \$18,897.41.

The motion carried by unanimous vote.

**12. FINANCIAL STATEMENTS**

- A. May 2018 Revenue & Expenditure Report
- B. 2017 Final Revenue & Expenditure Report

It was moved by Lansing, supported by Jefferson, to receive the May 2018 Revenue & Expenditure report and the 2017 Final Revenue & Expenditure report.

The motion carried by unanimous vote.

**13. PLEAS and PETITIONS**

- Chair Morris received a letter from Jack Smiley regarding the preservation of an 80 acre parcel of land on Berry Road. The board of trustees has pledged \$20,000.00 towards the preservation. The Superior Land Preservation Society has also pledged \$20,000.00. Jack Smiley is reaching out to individuals for pledges as well. He is also working with the Audubon Society, the City of Ann Arbor and The Greenbelt Group amongst others. He does not want money at this moment. He wants to secure the pledges to make his case for preservation stronger. The land appraised at \$693,000.00 and the conservation easement was appraised at \$492,000.00. He needs pledges of around \$200,000.00. The Audubon Society found over 40 different species of birds on the land.

**14. ADJOURNMENT**

It was moved by Sanii-Yahyai, supported by Morris, to adjourn the meeting.

The meeting adjourned at 7:14 p.m.

Respectfully submitted,

Paula Jefferson, Park Commissioner & Co-Chair



# WASHTENAW COUNTY OFFICE OF THE SHERIFF



JERRY L. CLAYTON  
SHERIFF

2201 Hogback Road ♦ Ann Arbor, Michigan 48105-9732 ♦ OFFICE (734) 971-8400 ♦ FAX (734) 973-4624 ♦ EMAIL [sheriffinfo@ewashtenaw.org](mailto:sheriffinfo@ewashtenaw.org)

MARK A. PTASZEK  
UNDERSHERIFF

July 6<sup>th</sup>, 2018

**TO:** Ken Schwartz, Superior Township Supervisor  
**FR:** Keith Flores, Lieutenant (Ann Arbor, Salem, Superior and York Townships)  
**TH:** Marlene Radzik, Commander  
**RE:** June 2018 Police Services Monthly Report

In June of 2018 there were 870 calls for service in Superior Township, compared to 888 in June 2017 (including traffic stops).

For the month of June 2018, deputies initiated 331 traffic stops and issued 113 citations compared to 288 traffic stops and 60 citations in June 2017.

Information on **significant events** this month includes:

--

- June 4<sup>th</sup> Church and Short, Felony warrant arrest, Deputy Mercure 18-42573
- June 6<sup>th</sup> 5300Blk of E Huron River, Felony warrant arrest, Deputy Mercure 18-43026
- June 6<sup>th</sup> 8600blk of Macarthur, Misdemeanor warrant arrest, Deputy Woollams 18-43163
- June 6<sup>th</sup> 1500blk of Ridge, Home invasion, Deputy Mcgrady 18-43190
- June 9<sup>th</sup> 9100blk of Panama, Attempt suicide, Deputy Scafasci 18-44065
- June 9<sup>th</sup> 5500blk of Great Hawk, Suicide, Deputy Houk 18-44104
- June 10<sup>th</sup> Panama and Stamford, Felony warrant arrest, Deputy Woollams 18-44369
- June 11<sup>th</sup> Macarthur Blvd and Macarthur St, Aggravated assault, Deputy Houk 18-44609
- June 13<sup>th</sup> 1900blk of Superior, Identity theft, Deputy Ross 18-45208
- June 13<sup>th</sup> 8600blk of Macarthur, CSC, Deputy Mercure 18-45226
- June 14<sup>th</sup> 8800blk of Macarthur, Misdemeanor warrant arrest, Deputy Buffa 18-45426
- June 14<sup>th</sup> 9500blk of Plymouth, Burglary, Deputy Mercure 18-45431
- June 16<sup>th</sup> 5300blk of E. Huron River, Misdemeanor warrant arrest, Deputy Ross 18-45978
- June 19<sup>th</sup> 1500blk of Ridge, Credit card fraud, Deputy Wallace 18-47066
- June 20<sup>th</sup> 5700blk of Plymouth, Burglary, Deputy Buffa 18-47155
- June 21<sup>st</sup> 9600blk of Cherry Hill, Stolen vehicle, Deputy Woollams 18-47551
- June 21<sup>st</sup> 1500blk of Wiard, Aggravated assault, Deputy Mcgrady 18-47680

**Incidents cont.**

- June 23<sup>rd</sup> 8700blk of Macarthur, Recovered stolen vehicle, Deputy Mcgrady 18-48169
- June 26<sup>th</sup> Prospect and Clark, Foot pursuit/resisting officer, Deputy Houk 18-48992
- June 27<sup>th</sup> Leforge and Clark, Misdemeanor warrant arrest, Deputy Wallace 18-49169
- June 27<sup>th</sup> 8800blk of Nottingham, Dog Bite, Deputy Schroeder 18-49238
- June 30<sup>th</sup> 1800blk of Manchester, MDOP, Deputy Scafasci 18-50190

CSC-Criminal sexual conduct

MDOP-Malicious destruction of property

LFA-Larceny from auto



# Washtenaw County Sheriff's Activity Log

Out of Area Report (Sorted by Date/Time, then Log ID)

7/3/2018 12:37 PM

Assignment Area: Superior Twp/Ann Arbor Twp

6/1/2018 - 6/30/2018

Log #	Deputy ID / Name	Date/Time	Area	Minutes
696556	1714 YEE, RAY <b>Type:</b> Court(Overtime) <b>Comments:</b> 18WD04375 GUILTY WITH EXPLANATION	6/01/18 8:30	Ypsilanti Twp.	45
697185	351 CROVA, JOSEPH <b>Type:</b> Service Requests <b>Comments:</b> disp: no assaults both groups advised (large fight 30 people OK by Sgt Gieskie to respond)	6/05/18 14:30	Ypsilanti Twp.	60
697159	746 MERCURE, THOMAS <b>Type:</b> Service Request Assist <b>Comments:</b> ASSIST SGT. GEISKE COMMAND	6/05/18 14:45	Ypsilanti Twp.	25
697342	746 MERCURE, THOMAS <b>Type:</b> Service Request Assist <b>Comments:</b> ASSIST WITH SCENE SECURITY/ SGT. CAMPBELL	6/06/18 12:00	Salem Twp.	60
697416	1986 HOUK, RICHARD <b>Type:</b> Service Requests <b>Comments:</b> K-9 TRACK FOR RISHA 760 ON B/E SGT. CAMPBELL	6/06/18 12:00	Salem Twp.	45
697342	746 MERCURE, THOMAS <b>Type:</b> Service Request Assist <b>Comments:</b> ASSISTED YPSI WITH BANK ROBBERY CAPTURE AND ARREST	6/06/18 14:20	Ypsilanti Twp.	85
697416	1986 HOUK, RICHARD <b>Type:</b> Service Requests <b>Comments:</b> BANK ROBBERY SUSPECT IN CUSTODY SGT. CAMPBELL	6/06/18 14:25	Ypsilanti Twp.	15
697416	1986 HOUK, RICHARD <b>Type:</b> Service Requests <b>Comments:</b> HI IN PROGRESS / FOUND TO BE HOME OWNER SGT. CAMPBELL	6/06/18 14:40	Ypsilanti Twp.	20
697416	1986 HOUK, RICHARD <b>Type:</b> Service Requests <b>Comments:</b> JAIL SNIFF W/ K9 OUT OF AREA TIME SGT. HOY	6/06/18 15:00	Pittsfield Twp.	120
697497	1123 WALLACE, SAMUEL <b>Type:</b> Service Requests <b>Comments:</b> DISPO: ASSIST UNITS / POSS B&E IN PROGRESS (SGT HUNT)	6/07/18 1:00	Ypsilanti Twp.	20
697942	1123 WALLACE, SAMUEL <b>Type:</b> Service Request Assist <b>Comments:</b> Dispo: Backed YPD w/Disorderly Party call. Approved by Sgt. Peltier.	6/09/18 22:50	Ypsilanti (city)	20
697942	1123 WALLACE, SAMUEL <b>Type:</b> Service Request Assist <b>Comments:</b> Dispo: Backed YPD w/return disorderly party call. Approved by Sgt. Pennington.	6/09/18 23:40	Ypsilanti (city)	15
697956	1081 BUFFA, DANIEL <b>Type:</b> Service Request Assist <b>Comments:</b> ASSIST YPSI WITH DISORDERLY SGT. CAMPBELL	6/10/18 4:40	Ypsilanti Twp.	50
697956	1081 BUFFA, DANIEL <b>Type:</b> Service Request Assist <b>Comments:</b> ASSIST YPSI WITH DV SGT. CAMPBELL	6/10/18 6:30	Ypsilanti Twp.	50
697956	1081 BUFFA, DANIEL <b>Type:</b> Service Request Assist <b>Comments:</b> ASSIST YPSI WITH ALARM SGT. CAMPBELL	6/10/18 7:20	Ypsilanti Twp.	20

698065	1780 SMITH, JESSE		<b>Date/Time:</b> 6/10/18 22:30	<b>Minutes:</b> 10
<b>Type:</b>	Service Request Assist	<b>Location:</b> DESOTO/TYLER	<b>Area:</b> Ypsilanti Twp.	
<b>Comments:</b>	assist ypsi units sgt peltier approved			
698065	1780 SMITH, JESSE		<b>Date/Time:</b> 6/10/18 22:40	<b>Minutes:</b> 10
<b>Type:</b>	Traffic Stop	<b>Location:</b>	<b>Area:</b> Ypsilanti Twp.	
<b>Comments:</b>	vw			
698153	1986 HOUK, RICHARD		<b>Date/Time:</b> 6/11/18 18:00	<b>Minutes:</b> 75
<b>Type:</b>	Service Requests	<b>Location:</b> POINEER HIGH SCHOOL	<b>Area:</b> Ann Arbor (city)	
<b>Comments:</b>	K9 SNIFF OF SEMI TRUCK FOR AAPD AND MSP - 3 HITS NO NARCOTICS FOUND. SGT. HUNT			
698230	746 MERCURE, THOMAS		<b>Date/Time:</b> 6/11/18 18:00	<b>Minutes:</b> 120
<b>Type:</b>	Special Detail	<b>Location:</b>	<b>Area:</b> Barton Hills	
<b>Comments:</b>	ATTEND BARTON HILLS VILLAGE MEETING			
698238	1123 WALLACE, SAMUEL		<b>Date/Time:</b> 6/11/18 21:00	<b>Minutes:</b> 35
<b>Type:</b>	Service Request Assist	<b>Location:</b> 1405 ECORSE RD	<b>Area:</b> Ypsilanti Twp.	
<b>Comments:</b>	Dispo: Backed Ypsi Twp units w/Elks Lodge Disorderly call. Approved by Sgt. Hunt.			
698590	1123 WALLACE, SAMUEL		<b>Date/Time:</b> 6/13/18 20:30	<b>Minutes:</b> 30
<b>Type:</b>	Service Request Assist	<b>Location:</b> 2120 ARBOR CIR W	<b>Area:</b> Pittsfield Twp.	
<b>Comments:</b>	Assist PTPD w/Shooting investigation. Approved by Sgt. Peltier.			
698590	1123 WALLACE, SAMUEL		<b>Date/Time:</b> 6/13/18 21:00	<b>Minutes:</b> 75
<b>Type:</b>	Service Request Assist	<b>Location:</b> 2269 GLENCOE HILLS APT 11	<b>Area:</b> Pittsfield Twp.	
<b>Comments:</b>	Dispo: Threats complaint related to PTPD shooting. See Case #18-45357 for details. Approved by Sgt. Peltier.			
698590	1123 WALLACE, SAMUEL		<b>Date/Time:</b> 6/13/18 22:15	<b>Minutes:</b> 55
<b>Type:</b>	Service Request Assist	<b>Location:</b> TEXTILE/ELIIS	<b>Area:</b> Ypsilanti Twp.	
<b>Comments:</b>	Dispo: Assisted Ypsi Twp units w/possible abduction in progress call. Unfounded.			
698631	746 MERCURE, THOMAS		<b>Date/Time:</b> 6/14/18 13:55	<b>Minutes:</b> 5
<b>Type:</b>	Service Requests	<b>Location:</b> 1421 RUE DEAUVILLE	<b>Area:</b> Ypsilanti Twp.	
<b>Comments:</b>	CANCELLED SGT GEISKE			
698904	1691 TOTH, GRANT		<b>Date/Time:</b> 6/15/18 21:00	<b>Minutes:</b> 30
<b>Type:</b>	Service Request Assist	<b>Location:</b> 772 GREEN	<b>Area:</b> Ypsilanti (city)	
<b>Comments:</b>	ASSIST YPD WITH HOMICIDE			
699145	1802 MCGRADY, PATRICK		<b>Date/Time:</b> 6/17/18 16:30	<b>Minutes:</b> 55
<b>Type:</b>	Service Request Assist	<b>Location:</b> 8871 SALEM FARMS	<b>Area:</b> Salem Twp.	
<b>Comments:</b>	assist Gorney w mental/suicidal, Peltier authorized			
699159	1123 WALLACE, SAMUEL		<b>Date/Time:</b> 6/17/18 22:20	<b>Minutes:</b> 15
<b>Type:</b>	Service Request Assist	<b>Location:</b> 1258 RUE WILLETTE BLVD	<b>Area:</b> Ypsilanti Twp.	
<b>Comments:</b>	Dispo: Backed Ypsi Twp units w/B&E in progress call. Unfounded. Approved by Sgt. Pennington.			
699337	2170 TRASKOS, RICHARD		<b>Date/Time:</b> 6/19/18 4:00	<b>Minutes:</b> 0
<b>Type:</b>	Administrative Duty	<b>Location:</b>	<b>Area:</b> Ypsilanti Twp.	
<b>Comments:</b>	OUT OF SERVICE			
700137	1802 MCGRADY, PATRICK		<b>Date/Time:</b> 6/23/18 18:10	<b>Minutes:</b> 50
<b>Type:</b>	Service Request Assist	<b>Location:</b> 1218 FALL RIVER	<b>Area:</b> Ypsilanti Twp.	
<b>Comments:</b>	assist Traskos w family trouble per Sgt. Peltier			
700602	1123 WALLACE, SAMUEL		<b>Date/Time:</b> 6/26/18 23:35	<b>Minutes:</b> 15
<b>Type:</b>	Service Request Assist	<b>Location:</b> 204 OREGON ST	<b>Area:</b> Ypsilanti Twp.	
<b>Comments:</b>	Dispo: Backed Ypsi Twp units w/suspicious incident ref OD follow up. Approved by Sgt. Mahalick.			
700817	746 MERCURE, THOMAS		<b>Date/Time:</b> 6/28/18 15:00	<b>Minutes:</b> 40
<b>Type:</b>	Service Requests	<b>Location:</b> 9790 OAK POINT LN	<b>Area:</b> Salem Twp.	
<b>Comments:</b>	LFA- APPROVED BY LT FLORES (WALK IN STATION 6)			

**Total Minutes: 1270**

**( 21 hours 10 minutes )**

<b>Ann Arbor (city):</b>	<b>1</b>	<b>trips totaling</b>	<b>75</b>	<b>minutes</b>
<b>Barton Hills:</b>	<b>1</b>	<b>trips totaling</b>	<b>120</b>	<b>minutes</b>
<b>Pittsfield Twp.:</b>	<b>3</b>	<b>trips totaling</b>	<b>225</b>	<b>minutes</b>
<b>Salem Twp.:</b>	<b>4</b>	<b>trips totaling</b>	<b>200</b>	<b>minutes</b>
<b>Ypsilanti (city):</b>	<b>3</b>	<b>trips totaling</b>	<b>65</b>	<b>minutes</b>
<b>Ypsilanti Twp.:</b>	<b>19</b>	<b>trips totaling</b>	<b>585</b>	<b>minutes</b>

# Superior Township Four Year Activity Report – JUNE, 2018

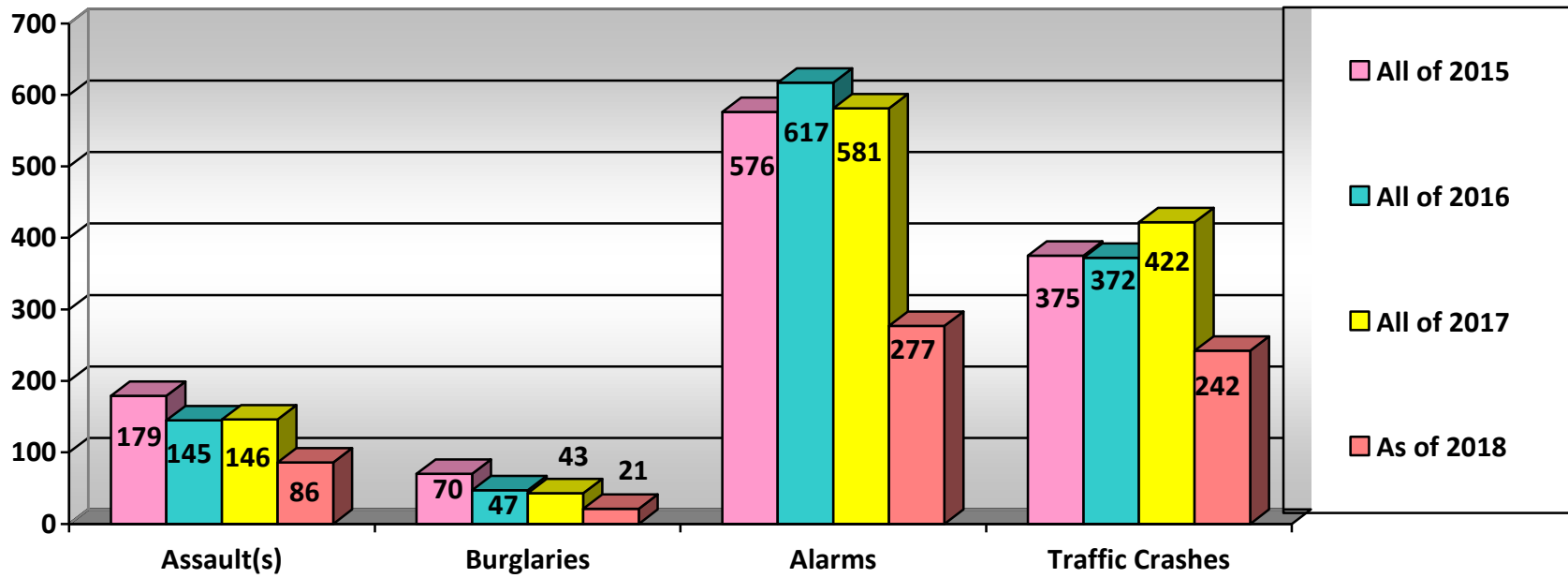
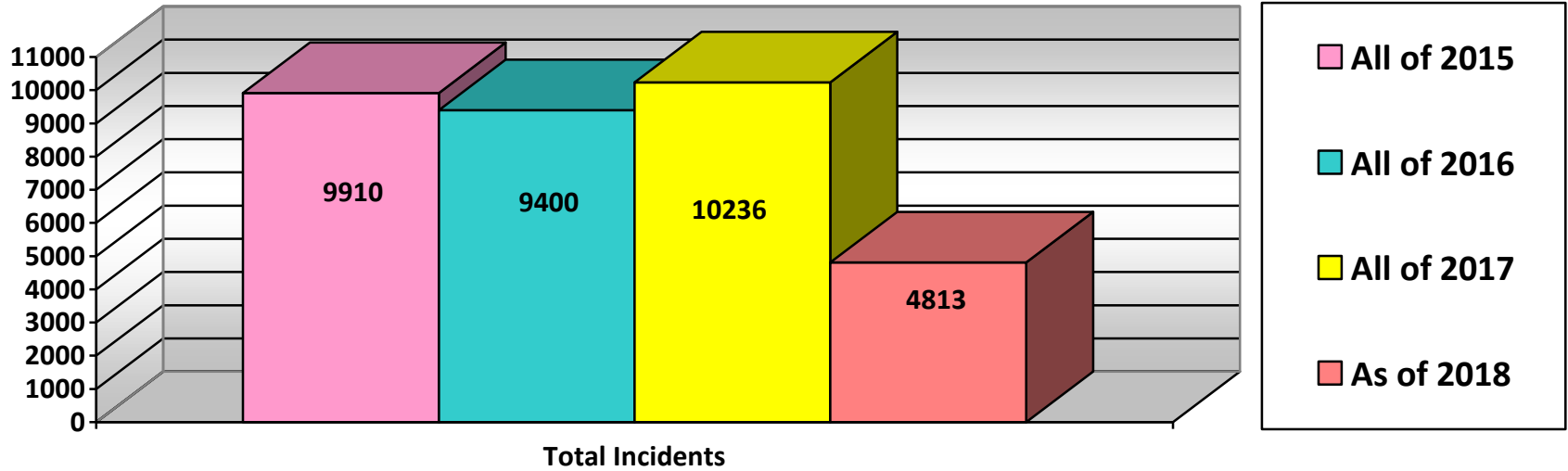

# Washtenaw County Sheriff's Activity Log

## Individual Deputy Statistical Report

Date Range: 6/1/2018 - 6/30/2018

Superior Twp/Ann Arbor Twp

	Shifts	Shifts w/Partner	Service Requests	Traffic Stops	Reports Written	UD-10s	SR & TS Ending in Arrest	Misdemeanor Arrests (SI)	Felony Arrests (SI)	Self Initiated Warrant Arrests	Warrant Meets / Pick Ups	Misdemeanor Citations	Civil Infractions	Parking Citations	OUIL Arrests
45 BLANCHARD, KEVIN	1				0	0	0	0	0	0	0	0	0	0	0
1081 BUFFA, DANIEL	15	8	27	19	11	3	0	1	1	0	0	0	1	0	1
1810 CARTER, ANDREW	1		1	0	0	0	0	0	0	0	0	0	0	0	0
351 CROVA, JOSEPH	28	1	38	95	13	7	0	0	0	0	0	2	11	0	0
1152 DEZWAAN, KEITH	2		4	0	0	0	0	0	0	0	0	0	0	0	0
2175 ERBES, JORDAN		1													
1775 FARMER HEWITT, HOLLY	24		55	38	4	1	0	2	0	0	0	2	9	0	0
793 GONTARSKI, JEFFREY	16		48	48	7	4	0	0	0	0	0	0	6	0	0
1986 HOUK, RICHARD	19		58	48	12	2	0	1	2	1	0	3	37	0	0
917 KIRBY, MARCUS	1				0	0	0	0	0	0	0	0	0	0	0
1355 LARKIN, ERIN	1		2	0	0	0	0	0	0	0	0	0	0	0	0
958 LOSEY, ROBERT	1		3	0	2	0	0	0	0	0	0	0	0	0	0
1582 LOWE, GARY	1		3	0	0	0	0	0	0	0	0	0	0	0	0
2113 MCFADDEN III, ROBERT	1				0	0	0	0	0	0	0	0	0	0	0
1802 MCGRADY, PATRICK	20	8	45	33	16	2	0	0	0	0	0	0	9	0	0
746 MERCURE, THOMAS	27		46	48	15	3	1	0	0	1	2	2	18	0	0
2295 PEARSON, AUSTIN	1		5	2	1	0	0	0	0	0	0	0	0	0	0
1050 ROSS, JEREMY	18		60	42	16	1	0	0	0	0	0	0	1	0	0
1750 ROY, JAMES		1													
1140 SAYDAK, SHARON	1		2	0	0	0	0	3	0	0	0	0	0	0	0
461 SCAFASCI, JOHN	8		10	0	4	2	0	0	0	0	0	0	0	0	0
1762 SEXTON, DAVID	5		6	5	1	0	0	0	0	0	0	0	0	0	0
1780 SMITH, JESSE	11	10	20	29	2	0	0	0	0	0	0	1	9	0	0
570 STUCK, RYAN	2		5	1	3	0	0	0	0	0	0	0	0	0	0
1691 TOTH, GRANT	9	5	9	9	2	0	0	0	0	0	0	2	2	0	0
2170 TRASKOS, RICHARD	1				0	0	0	0	0	0	0	0	0	0	0



2284 TURPIN, KAITLIN	1		2	0	0	0	0	0	0	0	0	0	0	0	0
1138 VISEL, GERROD	1		2	0	0	0	0	0	0	0	0	0	0	0	0
1123 WALLACE, SAMUEL	16	4	34	27	5	0	1	0	1	0	0	2	4	0	0
1715 WEBB, BRIAN	1		2	0	0	0	0	0	0	0	0	0	0	0	0
981 WIESE, DEREK	2	1	4	0	0	0	0	0	0	0	0	0	0	0	0
2223 WOOLLAMS, JOHNNY	20	3	26	42	5	0	1	0	1	0	0	8	1	0	0
1714 YEE, RAY	1		0	1	0	0	0	0	0	0	0	0	0	0	0
Grand Total:	256	42	517	487	119	25	3	7	5	2	2	22	108	0	1

# CLR-008 Monthly Summary Of Offenses (WD)

City:Superior Twp-SUT

---



<b>Month:</b>	June
<b>Year:</b>	2018
<b>Print Option:</b>	Print Both Monthly and YTD
<b>Include Unfounded:</b>	No
<b>Report Offenses:</b>	Include All (1,2,3,4)
<b>Attempted/Completed/NA:</b>	Includes Attempted
<b>City:</b>	Superior Twp-SUT

# CLR-008 Monthly Summary Of Offenses (WD)

## City:Superior Twp-SUT

For The Month Of June

Classification	Jun/2017	Jun/2018	%Change
11008 SEXUAL CONTACT FORCIBLE -CSC 4TH DEGREE	1	0	-100%
22001 BURGLARY -FORCED ENTRY	1	0	-100%
23005 LARCENY -THEFT FROM MOTOR VEHICLE	0	0	0%
25000 FORGERY/COUNTERFEITING	0	0	0%
26001 FRAUD -FALSE PRETENSE/SWINDLE/CONFIDENCE GAME	0	0	0%
26002 FRAUD -CREDIT CARD/AUTOMATIC TELLER MACHINE	0	0	0%
26007 FRAUD - IDENTITY THEFT	0	0	0%
35001 VIOLATION OF CONTROLLED SUBSTANCE ACT	0	0	0%
<b>Group A Totals</b>	<b>2</b>	<b>0</b>	<b>-100%</b>
49000 ESCAPE/FLIGHT	0	0	0%
50000 OBSTRUCTING JUSTICE	0	0	0%
<b>Group B Totals</b>	<b>0</b>	<b>0</b>	<b>0%</b>
3200 SICK / INJURY COMPLAINT	0	0	0%
3300 MISCELLANEOUS COMPLAINTS	0	0	0%
<b>Group C Totals</b>	<b>0</b>	<b>0</b>	<b>0%</b>
<b>City : Superior Twp Totals</b>	<b>2</b>	<b>0</b>	<b>-100%</b>

# CLR-008 Monthly Summary Of Offenses (WD)

## City:Superior Twp-SUT

Year To Date Through June

Classification	2017	2018	%Change
<b>Group C Totals</b>	<b>0</b>	<b>0</b>	<b>0%</b>
11008 SEXUAL CONTACT FORCIBLE -CSC 4TH DEGREE	1	0	-100%
22001 BURGLARY -FORCED ENTRY	2	0	-100%
23005 LARCENY -THEFT FROM MOTOR VEHICLE	0	5	0%
25000 FORGERY/COUNTERFEITING	1	0	-100%
26001 FRAUD -FALSE PRETENSE/SWINDLE/CONFIDENCE GAME	0	4	0%
26002 FRAUD -CREDIT CARD/AUTOMATIC TELLER MACHINE	1	0	-100%
26007 FRAUD - IDENTITY THEFT	1	0	-100%
35001 VIOLATION OF CONTROLLED SUBSTANCE ACT	0	1	0%
<b>Group A Totals</b>	<b>6</b>	<b>10</b>	<b>66.66%</b>
49000 ESCAPE/FLIGHT	0	1	0%
50000 OBSTRUCTING JUSTICE	2	1	-50%
<b>Group B Totals</b>	<b>2</b>	<b>2</b>	<b>0%</b>
3200 SICK / INJURY COMPLAINT	2	0	-100%
3300 MISCELLANEOUS COMPLAINTS	1	0	-100%
<b>Group C Totals</b>	<b>3</b>	<b>0</b>	<b>-100%</b>
<b>City : Superior Twp Totals</b>	<b>11</b>	<b>12</b>	<b>9.090%</b>



# Washtenaw County Sheriff's Activity Log

**Area:** 16 Superior Twp.  
**Date:** 6/1/2018 - 6/30/2018  
**Range:**

## Activity Log Citation by Area Report

<b>Log ID:</b> 696525	<b>Date:</b> 6/1/2018 2:16 AM	<b>Location:</b> GEDDES/PROSPECT	<b>Ticket #:</b> 4831	<b>Deputy:</b> SMITH, JESSE
<b>Citation 1:</b> C/I speed		<b>Citation 2:</b> C/I impeded		
<b>Log ID:</b> 696525	<b>Date:</b> 6/1/2018 1:43 AM	<b>Location:</b> GEDDES/HUNTERS CK	<b>Ticket #:</b>	<b>Deputy:</b> SMITH, JESSE
<b>Log ID:</b> 696527	<b>Date:</b> 6/1/2018 5:38 AM	<b>Location:</b> CLARK / DEVON	<b>Ticket #:</b>	<b>Deputy:</b> KRINGS, NICHOLAS
<b>Log ID:</b> 696556	<b>Date:</b> 6/1/2018 10:34 AM	<b>Location:</b> FORD/PROSPECT	<b>Ticket #:</b>	<b>Deputy:</b> YEE, RAY
<b>Log ID:</b> 696628	<b>Date:</b> 6/1/2018 7:02 PM	<b>Location:</b> GEDDES & PROSPECT	<b>Ticket #:</b> 18WD4855	<b>Deputy:</b> GONTARSKI, JEFFREY
<b>Citation 1:</b> C/I IMPROPER PASSING				
<b>Log ID:</b> 696713	<b>Date:</b> 6/1/2018 11:18 PM	<b>Location:</b> GEDDES / PROSPECT	<b>Ticket #:</b> 18WD04864	<b>Deputy:</b> KRINGS, NICHOLAS
<b>Citation 1:</b> C/I License & Registration				
<b>Log ID:</b> 696722	<b>Date:</b> 6/2/2018 2:53 AM	<b>Location:</b> HARRIS / MACARTHUR	<b>Ticket #:</b>	<b>Deputy:</b> PEARSON, AUSTIN
<b>Log ID:</b> 696722	<b>Date:</b> 6/2/2018 1:38 AM	<b>Location:</b> DEERING / MACARTHUR	<b>Ticket #:</b>	<b>Deputy:</b> PEARSON, AUSTIN
<b>Log ID:</b> 696740	<b>Date:</b> 6/2/2018 3:38 PM	<b>Location:</b> LEFORGE & GEDDES	<b>Ticket #:</b> 18WD4877	<b>Deputy:</b> GONTARSKI, JEFFREY
<b>Citation 1:</b> C/I IMPEDING				
<b>Log ID:</b> 696751	<b>Date:</b> 6/2/2018 10:04 AM	<b>Location:</b> RIDGE/GEDDES	<b>Ticket #:</b>	<b>Deputy:</b> ROSS, JEREMY
<b>Log ID:</b> 696751	<b>Date:</b> 6/2/2018 10:58 AM	<b>Location:</b> PLYMOUTH/BERRY	<b>Ticket #:</b>	<b>Deputy:</b> ROSS, JEREMY
<b>Log ID:</b> 696765	<b>Date:</b> 6/2/2018 2:25 PM	<b>Location:</b> BERKSHIRE / PROSPECT	<b>Ticket #:</b> 18WD4873	<b>Deputy:</b> HOUK, RICHARD
<b>Citation 1:</b> C/I SPEED		<b>Citation 2:</b> C/I IMPEDED TRAFFIC		
<b>Log ID:</b> 696765	<b>Date:</b> 6/2/2018 2:54 PM	<b>Location:</b> BERKSHIRE / PROSPECT	<b>Ticket #:</b> 18WD4875	<b>Deputy:</b> HOUK, RICHARD
<b>Citation 1:</b> C/I SPEED		<b>Citation 2:</b> C/I IMPEDED TRAFFIC		<b>Citation3:</b> C/I EXPIRED PLATE
<b>Log ID:</b> 696797	<b>Date:</b> 6/2/2018 5:58 PM	<b>Location:</b> GEDDES/HICKMAN	<b>Ticket #:</b> 18WD04878	<b>Deputy:</b> MCGRADY, PATRICK
<b>Citation 1:</b> C/I speed				
<b>Log ID:</b> 696816	<b>Date:</b> 6/2/2018 11:04 PM	<b>Location:</b> PROSPECT/VREELAND	<b>Ticket #:</b>	<b>Deputy:</b> MCGRADY, PATRICK
<b>Log ID:</b> 696816	<b>Date:</b> 6/3/2018 12:10 AM	<b>Location:</b> GEDDES/DIXBORO	<b>Ticket #:</b>	<b>Deputy:</b> MCGRADY, PATRICK

**Activity Log Citation by Area Report**

<b>Log ID:</b> 696816	<b>Date:</b> 6/2/2018 11:02 PM	<b>Location:</b> MACARTHUR/CLARK	<b>Ticket #:</b>	<b>Deputy:</b> MCGRADY, PATRICK
<b>Log ID:</b> 696839	<b>Date:</b> 6/3/2018 6:58 AM	<b>Location:</b> FORD/PROPSECT	<b>Ticket #:</b>	<b>Deputy:</b> SEXTON, DAVID
<b>Log ID:</b> 696839	<b>Date:</b> 6/3/2018 5:03 AM	<b>Location:</b> GEDDES/HARRIS	<b>Ticket #:</b>	<b>Deputy:</b> SEXTON, DAVID
<b>Log ID:</b> 696865	<b>Date:</b> 6/3/2018 9:19 AM	<b>Location:</b> FORD/PLYMOUTH	<b>Ticket #:</b>	<b>Deputy:</b> ROSS, JEREMY
<b>Log ID:</b> 696865	<b>Date:</b> 6/3/2018 10:32 AM	<b>Location:</b> DIXBORO/GEDDES	<b>Ticket #:</b>	<b>Deputy:</b> ROSS, JEREMY
<b>Log ID:</b> 696865	<b>Date:</b> 6/3/2018 11:16 AM	<b>Location:</b> LEFORGE/CLARK	<b>Ticket #:</b>	<b>Deputy:</b> ROSS, JEREMY
<b>Log ID:</b> 696915	<b>Date:</b> 6/3/2018 1:36 PM	<b>Location:</b> PROSPECT / CLARK	<b>Ticket #:</b> 18WD4897	<b>Deputy:</b> HOUK, RICHARD
<b>Citation 1:</b> C/I SPEED		<b>Citation 2:</b> C/I IMPEDED TRAFFIC		
<b>Log ID:</b> 696944	<b>Date:</b> 6/4/2018 3:34 AM	<b>Location:</b> RIDGE/SCARLET OAK	<b>Ticket #:</b>	<b>Deputy:</b> FARMER HEWITT, HOLLY
<b>Log ID:</b> 696944	<b>Date:</b> 6/4/2018 3:40 AM	<b>Location:</b> DIXBORO/LAUREL GARDENS	<b>Ticket #:</b> 18WD04910	<b>Deputy:</b> FARMER HEWITT, HOLLY
<b>Citation 1:</b> C/I Other: impede		<b>Citation 2:</b> C/I Violation of posted speed limit		
<b>Log ID:</b> 696984	<b>Date:</b> 6/4/2018 12:00 PM	<b>Location:</b> PROSPECT/CHERRY HILL	<b>Ticket #:</b>	<b>Deputy:</b> ROSS, JEREMY
<b>Log ID:</b> 696984	<b>Date:</b> 6/4/2018 3:25 PM	<b>Location:</b> PLYMOUTH/BIRCH RUN	<b>Ticket #:</b>	<b>Deputy:</b> ROSS, JEREMY
<b>Log ID:</b> 696984	<b>Date:</b> 6/4/2018 8:57 AM	<b>Location:</b> FORD/PLYMOUTH	<b>Ticket #:</b>	<b>Deputy:</b> ROSS, JEREMY
<b>Log ID:</b> 696996	<b>Date:</b> 6/4/2018 9:01 AM	<b>Location:</b> PROSEPECT AND VREELAND	<b>Ticket #:</b> 18WD04923	<b>Deputy:</b> MERCURE, THOMAS
<b>Citation 1:</b> C/I Other: IMPEED				
<b>Log ID:</b> 697054	<b>Date:</b> 6/4/2018 5:29 PM	<b>Location:</b> GEDDES / PROSPECT	<b>Ticket #:</b> N/A	<b>Deputy:</b> HOUK, RICHARD
<b>Log ID:</b> 697054	<b>Date:</b> 6/4/2018 6:28 PM	<b>Location:</b> PROSPECT / HALLIE	<b>Ticket #:</b> N/A	<b>Deputy:</b> HOUK, RICHARD
<b>Log ID:</b> 697054	<b>Date:</b> 6/4/2018 6:48 PM	<b>Location:</b> STAMFORD / DAWN	<b>Ticket #:</b> 18WD4945	<b>Deputy:</b> HOUK, RICHARD
<b>Citation 1:</b> C/I IMPEDED TRAFFIC		<b>Citation 2:</b> C/I SPEED		
<b>Log ID:</b> 697054	<b>Date:</b> 6/4/2018 5:09 PM	<b>Location:</b> DAWN / PANAMA	<b>Ticket #:</b> 18WD4939	<b>Deputy:</b> HOUK, RICHARD
<b>Citation 1:</b> C/I SPEED		<b>Citation 2:</b> C/I IMPEDED TRAFFIC		<b>Citation3:</b> C/I EXPIRED PLATE
<b>Log ID:</b> 697091	<b>Date:</b> 6/4/2018 4:45 PM	<b>Location:</b> CHURCH/ SHORT	<b>Ticket #:</b> 18WD04936	<b>Deputy:</b> MERCURE, THOMAS
<b>Citation 1:</b> C/I IMPED				
<b>Log ID:</b> 697091	<b>Date:</b> 6/4/2018 5:00 PM	<b>Location:</b> CHURCH/ SHORT	<b>Ticket #:</b> 18WD04937	<b>Deputy:</b> MERCURE, THOMAS
<b>Citation 1:</b> C/I INSURANCE				
<b>Log ID:</b> 697091	<b>Date:</b> 6/4/2018 6:44 PM	<b>Location:</b> CHURCH/ SHORT	<b>Ticket #:</b>	<b>Deputy:</b> MERCURE, THOMAS
<b>Log ID:</b> 697091	<b>Date:</b> 6/4/2018 4:30 PM	<b>Location:</b> CHURCH/ SHORT	<b>Ticket #:</b>	<b>Deputy:</b> MERCURE, THOMAS

**Activity Log Citation by Area Report**

<b>Log ID:</b> 697159	<b>Date:</b> 6/5/2018 11:58 AM	<b>Location:</b> RIDGE NEAR MOTT RD	<b>Ticket #:</b> 18WD04954	<b>Deputy:</b> MERCURE, THOMAS
<b>Citation 1:</b> C/I BREAK LAMPS OUT				
<b>Log ID:</b> 697159	<b>Date:</b> 6/5/2018 1:47 PM	<b>Location:</b> FORD AND 153	<b>Ticket #:</b>	<b>Deputy:</b> MERCURE, THOMAS
<b>Log ID:</b> 697187	<b>Date:</b> 6/5/2018 12:54 PM	<b>Location:</b> PLYMOUTH/ALLENDALE	<b>Ticket #:</b>	<b>Deputy:</b> ROSS, JEREMY
<b>Log ID:</b> 697187	<b>Date:</b> 6/5/2018 10:20 AM	<b>Location:</b> PROSPECT/FORD	<b>Ticket #:</b>	<b>Deputy:</b> ROSS, JEREMY
<b>Log ID:</b> 697187	<b>Date:</b> 6/5/2018 1:32 PM	<b>Location:</b> GEDDES/HUNTERS CREEK	<b>Ticket #:</b>	<b>Deputy:</b> ROSS, JEREMY
<b>Log ID:</b> 697235	<b>Date:</b> 6/5/2018 3:09 PM	<b>Location:</b> PROSPECT / CLARK	<b>Ticket #:</b> N/A	<b>Deputy:</b> HOUK, RICHARD
<b>Log ID:</b> 697235	<b>Date:</b> 6/5/2018 2:07 PM	<b>Location:</b> PROSPECT / FORD	<b>Ticket #:</b> 18WD4961	<b>Deputy:</b> HOUK, RICHARD
<b>Citation 1:</b> C/I SPEED		<b>Citation 2:</b> C/I IMPEDED TRAFFIC		
<b>Log ID:</b> 697247	<b>Date:</b> 6/5/2018 4:30 PM	<b>Location:</b> SUPERIOR GEDDES	<b>Ticket #:</b> DIGI	<b>Deputy:</b> CROVA, JOSEPH
<b>Citation 1:</b> C/I impeded				
<b>Log ID:</b> 697247	<b>Date:</b> 6/5/2018 4:08 PM	<b>Location:</b> GEDDES SUPERIOR	<b>Ticket #:</b>	<b>Deputy:</b> CROVA, JOSEPH
<b>Log ID:</b> 697247	<b>Date:</b> 6/5/2018 3:41 PM	<b>Location:</b> PROSPECT GEDDES	<b>Ticket #:</b>	<b>Deputy:</b> CROVA, JOSEPH
<b>Log ID:</b> 697247	<b>Date:</b> 6/5/2018 3:52 PM	<b>Location:</b> GEDDES GALE	<b>Ticket #:</b>	<b>Deputy:</b> CROVA, JOSEPH
<b>Log ID:</b> 697247	<b>Date:</b> 6/5/2018 4:20 PM	<b>Location:</b> GEDDES GAIL	<b>Ticket #:</b> DIDG	<b>Deputy:</b> CROVA, JOSEPH
<b>Citation 1:</b> C/I impeded				
<b>Log ID:</b> 697247	<b>Date:</b> 6/5/2018 4:11 PM	<b>Location:</b> GEDDES GALE	<b>Ticket #:</b>	<b>Deputy:</b> CROVA, JOSEPH
<b>Log ID:</b> 697247	<b>Date:</b> 6/5/2018 5:01 PM	<b>Location:</b> PROSPECT PLYMOUTH	<b>Ticket #:</b>	<b>Deputy:</b> CROVA, JOSEPH
<b>Log ID:</b> 697247	<b>Date:</b> 6/5/2018 4:39 PM	<b>Location:</b> SUPERIOR GEDDES	<b>Ticket #:</b> DIGI	<b>Deputy:</b> CROVA, JOSEPH
<b>Citation 1:</b> C/I npi				
<b>Log ID:</b> 697263	<b>Date:</b> 6/5/2018 5:25 PM	<b>Location:</b> GEDES & LEFORGE	<b>Ticket #:</b> 18WD4968	<b>Deputy:</b> GONTARSKI, JEFFREY
<b>Citation 1:</b> C/I IMPEDING TRAFFIC				
<b>Log ID:</b> 697265	<b>Date:</b> 6/6/2018 3:32 AM	<b>Location:</b> PROSPECT/FORD	<b>Ticket #:</b>	<b>Deputy:</b> FARMER HEWITT, HOLLY
<b>Log ID:</b> 697296	<b>Date:</b> 6/6/2018 12:50 AM	<b>Location:</b> LEFORGE/HRD	<b>Ticket #:</b> 18WD04978	<b>Deputy:</b> WALLACE, SAMUEL
<b>Citation 1:</b> C/I Other: Impeded Traffic				
<b>Log ID:</b> 697296	<b>Date:</b> 6/6/2018 2:49 AM	<b>Location:</b> GEDDES/SUPERIOR	<b>Ticket #:</b>	<b>Deputy:</b> WALLACE, SAMUEL
<b>Log ID:</b> 697296	<b>Date:</b> 6/6/2018 2:52 AM	<b>Location:</b> GEDDES/DIXBORO	<b>Ticket #:</b>	<b>Deputy:</b> WALLACE, SAMUEL
<b>Log ID:</b> 697296	<b>Date:</b> 6/5/2018 10:35 PM	<b>Location:</b> LEFORGE/CLARK	<b>Ticket #:</b>	<b>Deputy:</b> WALLACE, SAMUEL
<b>Log ID:</b> 697363	<b>Date:</b> 6/6/2018 11:07 AM	<b>Location:</b> JOY/PLYMOUTH	<b>Ticket #:</b>	<b>Deputy:</b> ROSS, JEREMY

**Activity Log Citation by Area Report**

<b>Log ID:</b> 697436	<b>Date:</b> 6/6/2018 4:50 PM	<b>Location:</b> MACARTHUR HARRIS	<b>Ticket #:</b>	<b>Deputy:</b> CROVA, JOSEPH
<b>Log ID:</b> 697436	<b>Date:</b> 6/6/2018 4:41 PM	<b>Location:</b> MACARTHUR STAMFORD	<b>Ticket #:</b>	<b>Deputy:</b> CROVA, JOSEPH
<b>Log ID:</b> 697436	<b>Date:</b> 6/6/2018 4:17 PM	<b>Location:</b> PROSPECT CLARK	<b>Ticket #:</b>	<b>Deputy:</b> CROVA, JOSEPH
<b>Log ID:</b> 697436	<b>Date:</b> 6/6/2018 5:12 PM	<b>Location:</b> CLARK MACARTHUR	<b>Ticket #:</b>	<b>Deputy:</b> CROVA, JOSEPH
<b>Log ID:</b> 697436	<b>Date:</b> 6/6/2018 5:09 PM	<b>Location:</b> CLARK MACARTHUR	<b>Ticket #:</b>	<b>Deputy:</b> CROVA, JOSEPH
<b>Log ID:</b> 697436	<b>Date:</b> 6/6/2018 5:05 PM	<b>Location:</b> CLARK MACARTHUR	<b>Ticket #:</b>	<b>Deputy:</b> CROVA, JOSEPH
<b>Log ID:</b> 697436	<b>Date:</b> 6/6/2018 4:59 PM	<b>Location:</b> CLARK MACARTHUR	<b>Ticket #:</b>	<b>Deputy:</b> CROVA, JOSEPH
<b>Log ID:</b> 697436	<b>Date:</b> 6/6/2018 4:33 PM	<b>Location:</b> MACARTHUR HARRIS	<b>Ticket #:</b>	<b>Deputy:</b> CROVA, JOSEPH
<b>Log ID:</b> 697464	<b>Date:</b> 6/6/2018 11:30 PM	<b>Location:</b> GEDDES/TOWSLEY	<b>Ticket #:</b>	<b>Deputy:</b> MCGRADY, PATRICK
<b>Log ID:</b> 697464	<b>Date:</b> 6/6/2018 11:17 PM	<b>Location:</b> GEDDES/DIXBORO	<b>Ticket #:</b>	<b>Deputy:</b> MCGRADY, PATRICK
<b>Log ID:</b> 697497	<b>Date:</b> 6/7/2018 12:19 AM	<b>Location:</b> GEDDES/SUPERIOR	<b>Ticket #:</b>	<b>Deputy:</b> WALLACE, SAMUEL
<b>Log ID:</b> 697537	<b>Date:</b> 6/7/2018 2:46 PM	<b>Location:</b> FORD AND OLD FORD	<b>Ticket #:</b>	<b>Deputy:</b> MERCURE, THOMAS
<b>Log ID:</b> 697600	<b>Date:</b> 6/7/2018 2:08 PM	<b>Location:</b> GEDDES/GALE	<b>Ticket #:</b> 18WD05087	<b>Deputy:</b> WALLACE, SAMUEL
<b>Citation 1:</b> C/I Other: Impeded Traffic				
<b>Log ID:</b> 697600	<b>Date:</b> 6/7/2018 5:06 PM	<b>Location:</b> GEDDES/DIXBORO	<b>Ticket #:</b> 18WD05094	<b>Deputy:</b> WALLACE, SAMUEL
<b>Citation 1:</b> C/I Other: Impeded Traffic				
<b>Log ID:</b> 697640	<b>Date:</b> 6/8/2018 6:22 PM	<b>Location:</b> GEDDES/HICKMAN	<b>Ticket #:</b> 18WD05113	<b>Deputy:</b> MCGRADY, PATRICK
<b>Citation 1:</b> C/I impeding				
<b>Log ID:</b> 697812	<b>Date:</b> 6/8/2018 11:23 PM	<b>Location:</b> GEDDES/DIXBORO	<b>Ticket #:</b> 5161	<b>Deputy:</b> MCGRADY, PATRICK
<b>Citation 1:</b> C/I speed		<b>Citation 2:</b> C/I impeded		
<b>Log ID:</b> 697812	<b>Date:</b> 6/8/2018 11:04 PM	<b>Location:</b> PROSPECT/GEDDES	<b>Ticket #:</b>	<b>Deputy:</b> MCGRADY, PATRICK
<b>Log ID:</b> 697812	<b>Date:</b> 6/8/2018 10:44 PM	<b>Location:</b> GEDDES/TOWSLEY	<b>Ticket #:</b>	<b>Deputy:</b> MCGRADY, PATRICK
<b>Log ID:</b> 697812	<b>Date:</b> 6/8/2018 10:24 PM	<b>Location:</b> GEDDES/PROSPECT	<b>Ticket #:</b>	<b>Deputy:</b> MCGRADY, PATRICK
<b>Log ID:</b> 697812	<b>Date:</b> 6/8/2018 9:41 PM	<b>Location:</b> GEDDES/DIXBORO	<b>Ticket #:</b>	<b>Deputy:</b> MCGRADY, PATRICK
<b>Log ID:</b> 697812	<b>Date:</b> 6/8/2018 8:59 PM	<b>Location:</b> GEDDES/VALLEYVIEW	<b>Ticket #:</b>	<b>Deputy:</b> MCGRADY, PATRICK
<b>Log ID:</b> 697812	<b>Date:</b> 6/8/2018 6:40 PM	<b>Location:</b> GEDDES/DIXBORO	<b>Ticket #:</b>	<b>Deputy:</b> MCGRADY, PATRICK
<b>Log ID:</b> 697812	<b>Date:</b> 6/8/2018 10:37 PM	<b>Location:</b> GEDDES/TOWSLEY	<b>Ticket #:</b>	<b>Deputy:</b> MCGRADY, PATRICK
<b>Log ID:</b> 697921	<b>Date:</b> 6/9/2018 7:57 PM	<b>Location:</b> GEDDES/LEFORGE	<b>Ticket #:</b>	<b>Deputy:</b> FARMER HEWITT, HOLLY
<b>Log ID:</b> 697942	<b>Date:</b> 6/9/2018 11:16 PM	<b>Location:</b> LEFORGE/HRD	<b>Ticket #:</b>	<b>Deputy:</b> WALLACE, SAMUEL



**Activity Log Citation by Area Report**

<b>Log ID:</b> 697942	<b>Date:</b> 6/9/2018 10:36 PM	<b>Location:</b> LEFORGE/CLARK	<b>Ticket #:</b>	<b>Deputy:</b> WALLACE, SAMUEL
<b>Log ID:</b> 697950	<b>Date:</b> 6/9/2018 11:10 PM	<b>Location:</b> GEDDES/DIXBORO	<b>Ticket #:</b>	<b>Deputy:</b> MCGRADY, PATRICK
<b>Log ID:</b> 697950	<b>Date:</b> 6/9/2018 10:53 PM	<b>Location:</b> GEDDES/GALE	<b>Ticket #:</b> 18WD05177	<b>Deputy:</b> MCGRADY, PATRICK
<b>Citation 1:</b> C/I impeding				
<b>Log ID:</b> 697993	<b>Date:</b> 6/10/2018 10:31 AM	<b>Location:</b> GEDDES / HARRIS	<b>Ticket #:</b> N/A	<b>Deputy:</b> HOUK, RICHARD
<b>Log ID:</b> 697993	<b>Date:</b> 6/10/2018 12:48 PM	<b>Location:</b> DIXBORO / GEDDES	<b>Ticket #:</b> N/A	<b>Deputy:</b> HOUK, RICHARD
<b>Log ID:</b> 697993	<b>Date:</b> 6/10/2018 1:06 PM	<b>Location:</b> STAMFORD / DAWN	<b>Ticket #:</b> N/A	<b>Deputy:</b> HOUK, RICHARD
<b>Log ID:</b> 697993	<b>Date:</b> 6/10/2018 1:18 PM	<b>Location:</b> DAWN / CLARK	<b>Ticket #:</b> N/A	<b>Deputy:</b> HOUK, RICHARD
<b>Log ID:</b> 697993	<b>Date:</b> 6/10/2018 3:29 PM	<b>Location:</b> DIXBORO / GEDDES	<b>Ticket #:</b> N/A	<b>Deputy:</b> HOUK, RICHARD
<b>Log ID:</b> 697993	<b>Date:</b> 6/10/2018 4:56 PM	<b>Location:</b> BERKSHIRE / SHEFFIELD	<b>Ticket #:</b> 18WD5186	<b>Deputy:</b> HOUK, RICHARD
<b>Citation 1:</b> C/I SPEED		<b>Citation 2:</b> C/I IMPEDED TRAFFIC		
<b>Log ID:</b> 697993	<b>Date:</b> 6/10/2018 1:32 PM	<b>Location:</b> CLARK /DAWN	<b>Ticket #:</b> N/A	<b>Deputy:</b> HOUK, RICHARD
<b>Log ID:</b> 698013	<b>Date:</b> 6/10/2018 2:40 PM	<b>Location:</b> PROSPECT/BERKSHIRE	<b>Ticket #:</b>	<b>Deputy:</b> FARMER HEWITT, HOLLY
<b>Log ID:</b> 698065	<b>Date:</b> 6/10/2018 9:59 PM	<b>Location:</b> RIDGE/MOTT	<b>Ticket #:</b> 5190	<b>Deputy:</b> SMITH, JESSE
<b>Citation 1:</b> C/I expired				
<b>Log ID:</b> 698067	<b>Date:</b> 6/10/2018 10:38 PM	<b>Location:</b> PROSPECT/VREELAND	<b>Ticket #:</b>	<b>Deputy:</b> FARMER HEWITT, HOLLY
<b>Log ID:</b> 698067	<b>Date:</b> 6/10/2018 10:18 PM	<b>Location:</b> GEDDES/PROPSECT	<b>Ticket #:</b>	<b>Deputy:</b> FARMER HEWITT, HOLLY
<b>Log ID:</b> 698095	<b>Date:</b> 6/11/2018 9:21 AM	<b>Location:</b> HARRIS/GEDDES	<b>Ticket #:</b>	<b>Deputy:</b> MERCURE, THOMAS
<b>Log ID:</b> 698104	<b>Date:</b> 6/11/2018 9:49 AM	<b>Location:</b> PLYMOUTH/NAPIER	<b>Ticket #:</b>	<b>Deputy:</b> ROSS, JEREMY
<b>Log ID:</b> 698104	<b>Date:</b> 6/11/2018 11:21 AM	<b>Location:</b> PLYMOUTH/PROSPECT	<b>Ticket #:</b>	<b>Deputy:</b> ROSS, JEREMY
<b>Log ID:</b> 698153	<b>Date:</b> 6/11/2018 2:56 PM	<b>Location:</b> BERKSHIRE / PROSPECT	<b>Ticket #:</b> N/A	<b>Deputy:</b> HOUK, RICHARD
<b>Log ID:</b> 698153	<b>Date:</b> 6/11/2018 2:16 PM	<b>Location:</b> LAKEVIEW / BERKSHIRE	<b>Ticket #:</b> 18WD05219	<b>Deputy:</b> HOUK, RICHARD
<b>Citation 1:</b> C/I SPEED		<b>Citation 2:</b> C/I IMPEDED TRAFFIC		<b>Citation3:</b> C/I EXPIRED PLATE
<b>Log ID:</b> 698195	<b>Date:</b> 6/11/2018 5:10 PM	<b>Location:</b> CHURCH/ SHORT	<b>Ticket #:</b>	<b>Deputy:</b> MERCURE, THOMAS
<b>Log ID:</b> 698195	<b>Date:</b> 6/11/2018 5:22 PM	<b>Location:</b> CHURCH/ SHORT	<b>Ticket #:</b> 18WD05224	<b>Deputy:</b> MERCURE, THOMAS
<b>Citation 1:</b> C/I SPEED				
<b>Log ID:</b> 698195	<b>Date:</b> 6/11/2018 5:33 PM	<b>Location:</b> CHURCH/ SHORT	<b>Ticket #:</b> 18WD05225	<b>Deputy:</b> MERCURE, THOMAS
<b>Citation 1:</b> C/I IMPED				
<b>Log ID:</b> 698195	<b>Date:</b> 6/11/2018 4:34 PM	<b>Location:</b> DIXBORO/ FORD	<b>Ticket #:</b>	<b>Deputy:</b> MERCURE, THOMAS

**Activity Log Citation by Area Report**

<b>Log ID:</b> 698221	<b>Date:</b> 6/11/2018 8:56 PM	<b>Location:</b> RIDGE/SCARLET OAK	<b>Ticket #:</b>	<b>Deputy:</b> FARMER HEWITT, HOLLY
<b>Log ID:</b> 698221	<b>Date:</b> 6/11/2018 9:01 PM	<b>Location:</b> RIDGE/SCARLET OAK	<b>Ticket #:</b> 18WD05228	<b>Deputy:</b> FARMER HEWITT, HOLLY
<b>Citation 1:</b> C/I Other: impede traffic				
<b>Log ID:</b> 698221	<b>Date:</b> 6/11/2018 8:48 PM	<b>Location:</b> SUPERIOR/GEDDES	<b>Ticket #:</b>	<b>Deputy:</b> FARMER HEWITT, HOLLY
<b>Log ID:</b> 698238	<b>Date:</b> 6/12/2018 2:26 AM	<b>Location:</b> PROSPECT/FORD RD	<b>Ticket #:</b>	<b>Deputy:</b> WALLACE, SAMUEL
<b>Log ID:</b> 698256	<b>Date:</b> 6/12/2018 3:03 AM	<b>Location:</b> PROSPECT/BERKSHIRE	<b>Ticket #:</b> 18WD05235	<b>Deputy:</b> FARMER HEWITT, HOLLY
<b>Citation 1:</b> C/I Other: fail to signal turn				
<b>Log ID:</b> 698260	<b>Date:</b> 6/12/2018 6:11 AM	<b>Location:</b> FORD/GOTFREDSON	<b>Ticket #:</b>	<b>Deputy:</b> SEXTON, DAVID
<b>Log ID:</b> 698260	<b>Date:</b> 6/12/2018 6:24 AM	<b>Location:</b> PLYMOUTH/HICKORY RIDGE	<b>Ticket #:</b>	<b>Deputy:</b> SEXTON, DAVID
<b>Log ID:</b> 698275	<b>Date:</b> 6/12/2018 11:36 AM	<b>Location:</b> PROSPECT/ BERKSHIRE	<b>Ticket #:</b> 18WD05242	<b>Deputy:</b> MERCURE, THOMAS
<b>Citation 1:</b> C/I BRAKE LAMP				
<b>Log ID:</b> 698281	<b>Date:</b> 6/12/2018 12:36 PM	<b>Location:</b> GEDDES/GALE	<b>Ticket #:</b>	<b>Deputy:</b> ROSS, JEREMY
<b>Log ID:</b> 698281	<b>Date:</b> 6/12/2018 8:34 AM	<b>Location:</b> PROSPECT/CLARK	<b>Ticket #:</b>	<b>Deputy:</b> ROSS, JEREMY
<b>Log ID:</b> 698334	<b>Date:</b> 6/12/2018 4:46 PM	<b>Location:</b> GEDDES / SUPERIOR	<b>Ticket #:</b> N/A	<b>Deputy:</b> HOUK, RICHARD
<b>Log ID:</b> 698334	<b>Date:</b> 6/12/2018 3:40 PM	<b>Location:</b> DAWN / STAMFORD	<b>Ticket #:</b> N/A	<b>Deputy:</b> HOUK, RICHARD
<b>Log ID:</b> 698365	<b>Date:</b> 6/12/2018 6:12 PM	<b>Location:</b> SUPERIOR GEDDES	<b>Ticket #:</b> DIGI	<b>Deputy:</b> CROVA, JOSEPH
<b>Citation 1:</b> MISD no cycle endorse				
<b>Log ID:</b> 698365	<b>Date:</b> 6/12/2018 4:43 PM	<b>Location:</b> GEDDES GALE	<b>Ticket #:</b> DIGI	<b>Deputy:</b> CROVA, JOSEPH
<b>Citation 1:</b> MISD dwls <b>Citation 2:</b> C/I 45/40				
<b>Log ID:</b> 698365	<b>Date:</b> 6/12/2018 5:32 PM	<b>Location:</b> SUPERIOR FIRST	<b>Ticket #:</b>	<b>Deputy:</b> CROVA, JOSEPH
<b>Log ID:</b> 698365	<b>Date:</b> 6/12/2018 5:33 PM	<b>Location:</b> SUPERIOR FIRST	<b>Ticket #:</b>	<b>Deputy:</b> CROVA, JOSEPH
<b>Log ID:</b> 698365	<b>Date:</b> 6/12/2018 5:44 PM	<b>Location:</b> GEDDES LEFORGE	<b>Ticket #:</b>	<b>Deputy:</b> CROVA, JOSEPH
<b>Log ID:</b> 698365	<b>Date:</b> 6/12/2018 5:56 PM	<b>Location:</b> MACARTHUR STAMFORD	<b>Ticket #:</b>	<b>Deputy:</b> CROVA, JOSEPH
<b>Log ID:</b> 698365	<b>Date:</b> 6/12/2018 6:22 PM	<b>Location:</b> PROSPECT CLARK	<b>Ticket #:</b>	<b>Deputy:</b> CROVA, JOSEPH
<b>Log ID:</b> 698365	<b>Date:</b> 6/12/2018 7:07 PM	<b>Location:</b> MACARTHUR HARRIS	<b>Ticket #:</b>	<b>Deputy:</b> CROVA, JOSEPH
<b>Log ID:</b> 698370	<b>Date:</b> 6/12/2018 6:26 PM	<b>Location:</b> CHURCH/ SHORT	<b>Ticket #:</b> 18WD05271	<b>Deputy:</b> MERCURE, THOMAS
<b>Citation 1:</b> C/I IMPED				
<b>Log ID:</b> 698370	<b>Date:</b> 6/12/2018 7:19 PM	<b>Location:</b> PROSPECT/ CHERRY HILL	<b>Ticket #:</b>	<b>Deputy:</b> MERCURE, THOMAS

**Activity Log Citation by Area Report**

<b>Log ID:</b> 698370	<b>Date:</b> 6/12/2018 4:27 PM	<b>Location:</b> GEDDES/ SUPERIOR	<b>Ticket #:</b>	<b>Deputy:</b> MERCURE, THOMAS
<b>Log ID:</b> 698370	<b>Date:</b> 6/12/2018 5:19 PM	<b>Location:</b> GEDDES/ LEFORGE	<b>Ticket #:</b>	<b>Deputy:</b> MERCURE, THOMAS
<b>Log ID:</b> 698370	<b>Date:</b> 6/12/2018 5:13 PM	<b>Location:</b> GEDDES/ SUPERIOR	<b>Ticket #:</b> 18WD05265	<b>Deputy:</b> MERCURE, THOMAS
<b>Citation 1:</b> C/I BRAKE LAMP				
<b>Log ID:</b> 698370	<b>Date:</b> 6/12/2018 5:33 PM	<b>Location:</b> BERKSHIRE/ WILTSHIRE	<b>Ticket #:</b>	<b>Deputy:</b> MERCURE, THOMAS
<b>Log ID:</b> 698370	<b>Date:</b> 6/12/2018 4:47 PM	<b>Location:</b> SUPERIOR/ GEDDES	<b>Ticket #:</b> 18WD05263	<b>Deputy:</b> MERCURE, THOMAS
<b>Citation 1:</b> C/I BRAKE LAMP				
<b>Log ID:</b> 698370	<b>Date:</b> 6/12/2018 4:57 PM	<b>Location:</b> SUPERIOIR/ FIRST	<b>Ticket #:</b>	<b>Deputy:</b> MERCURE, THOMAS
<b>Log ID:</b> 698389	<b>Date:</b> 6/12/2018 11:14 PM	<b>Location:</b> PROSPECT/CLARK	<b>Ticket #:</b>	<b>Deputy:</b> FARMER HEWITT, HOLLY
<b>Log ID:</b> 698389	<b>Date:</b> 6/12/2018 6:38 PM	<b>Location:</b> RIDGE/MOTT	<b>Ticket #:</b> 18WD05266	<b>Deputy:</b> FARMER HEWITT, HOLLY
<b>Citation 1:</b> C/I Other: impede traffic				
<b>Log ID:</b> 698389	<b>Date:</b> 6/12/2018 11:21 PM	<b>Location:</b> FORD/CLARK	<b>Ticket #:</b>	<b>Deputy:</b> FARMER HEWITT, HOLLY
<b>Log ID:</b> 698426	<b>Date:</b> 6/13/2018 6:03 AM	<b>Location:</b> FORD AND NORTHBROOK	<b>Ticket #:</b>	<b>Deputy:</b> BUFFA, DANIEL
<b>Log ID:</b> 698433	<b>Date:</b> 6/13/2018 9:23 AM	<b>Location:</b> PROSPECT/ CHERRY HILL	<b>Ticket #:</b> 18WD0045177	<b>Deputy:</b> MERCURE, THOMAS
<b>Citation 1:</b> C/I INSUR				
<b>Log ID:</b> 698471	<b>Date:</b> 6/13/2018 9:42 AM	<b>Location:</b> LEFORGE/GEDDES	<b>Ticket #:</b>	<b>Deputy:</b> ROSS, JEREMY
<b>Log ID:</b> 698471	<b>Date:</b> 6/13/2018 9:43 AM	<b>Location:</b> GEDDES/SUPERIOR	<b>Ticket #:</b>	<b>Deputy:</b> ROSS, JEREMY
<b>Log ID:</b> 698471	<b>Date:</b> 6/13/2018 9:21 AM	<b>Location:</b> FORD/PROSPECT	<b>Ticket #:</b>	<b>Deputy:</b> ROSS, JEREMY
<b>Log ID:</b> 698471	<b>Date:</b> 6/13/2018 12:45 PM	<b>Location:</b> CLARK/WIARD	<b>Ticket #:</b>	<b>Deputy:</b> ROSS, JEREMY
<b>Log ID:</b> 698631	<b>Date:</b> 6/14/2018 10:12 AM	<b>Location:</b> PLYMOUTH/ CURTIS	<b>Ticket #:</b> 18WD05315	<b>Deputy:</b> MERCURE, THOMAS
<b>Citation 1:</b> C/I IMPED				
<b>Log ID:</b> 698631	<b>Date:</b> 6/14/2018 11:10 AM	<b>Location:</b> PLYMOUTH/ CURTIS	<b>Ticket #:</b>	<b>Deputy:</b> MERCURE, THOMAS
<b>Log ID:</b> 698718	<b>Date:</b> 6/14/2018 5:57 PM	<b>Location:</b> HOLMES MACARTHUR	<b>Ticket #:</b>	<b>Deputy:</b> CROVA, JOSEPH
<b>Log ID:</b> 698718	<b>Date:</b> 6/14/2018 7:12 PM	<b>Location:</b> CLARK HRD	<b>Ticket #:</b>	<b>Deputy:</b> CROVA, JOSEPH
<b>Log ID:</b> 698718	<b>Date:</b> 6/14/2018 4:18 PM	<b>Location:</b> DIXBORO FORD	<b>Ticket #:</b>	<b>Deputy:</b> CROVA, JOSEPH
<b>Log ID:</b> 698718	<b>Date:</b> 6/14/2018 4:26 PM	<b>Location:</b> CHERRY HILL PROSPECT	<b>Ticket #:</b>	<b>Deputy:</b> CROVA, JOSEPH
<b>Log ID:</b> 698718	<b>Date:</b> 6/14/2018 6:16 PM	<b>Location:</b> SUPERIOR HRD	<b>Ticket #:</b>	<b>Deputy:</b> CROVA, JOSEPH
<b>Log ID:</b> 698718	<b>Date:</b> 6/14/2018 6:32 PM	<b>Location:</b> CLRK MACARTHUR	<b>Ticket #:</b>	<b>Deputy:</b> CROVA, JOSEPH
<b>Log ID:</b> 698718	<b>Date:</b> 6/14/2018 3:58 PM	<b>Location:</b> DIXBORO PLYMOUTH	<b>Ticket #:</b>	<b>Deputy:</b> CROVA, JOSEPH

**Activity Log Citation by Area Report**

<b>Log ID:</b> 698718	<b>Date:</b> 6/14/2018 4:09 PM	<b>Location:</b> DIXBORO PLYMOUTH	<b>Ticket #:</b>	<b>Deputy:</b> CROVA, JOSEPH
<b>Log ID:</b> 698756	<b>Date:</b> 6/15/2018 10:06 PM	<b>Location:</b> CLARK/PROSPECT	<b>Ticket #:</b>	<b>Deputy:</b> MCGRADY, PATRICK
<b>Log ID:</b> 698769	<b>Date:</b> 6/14/2018 11:39 PM	<b>Location:</b> GEDDES/TOWSLEY	<b>Ticket #:</b>	<b>Deputy:</b> SMITH, JESSE
<b>Log ID:</b> 698769	<b>Date:</b> 6/14/2018 11:23 PM	<b>Location:</b> GEDDES/TOWSLEY	<b>Ticket #:</b>	<b>Deputy:</b> SMITH, JESSE
<b>Log ID:</b> 698769	<b>Date:</b> 6/14/2018 11:37 PM	<b>Location:</b> GEDDES/TOWSLEY	<b>Ticket #:</b> 5329	<b>Deputy:</b> SMITH, JESSE
<b>Citation 1:</b> C/I speed		<b>Citation 2:</b> C/I imped		<b>Citation3:</b> C/I insurance
<b>Log ID:</b> 698777	<b>Date:</b> 6/15/2018 5:51 AM	<b>Location:</b> DEVON AND CLARK	<b>Ticket #:</b>	<b>Deputy:</b> BUFFA, DANIEL
<b>Log ID:</b> 698797	<b>Date:</b> 6/15/2018 11:28 AM	<b>Location:</b> BERKSHIRE/ WILTSHIRE	<b>Ticket #:</b>	<b>Deputy:</b> MERCURE, THOMAS
<b>Log ID:</b> 698797	<b>Date:</b> 6/15/2018 11:38 AM	<b>Location:</b> BERKSHIRE/ WILTSHIRE	<b>Ticket #:</b>	<b>Deputy:</b> MERCURE, THOMAS
<b>Log ID:</b> 698797	<b>Date:</b> 6/15/2018 3:11 PM	<b>Location:</b> FORD/ PROSPECT	<b>Ticket #:</b> 18WD05336	<b>Deputy:</b> MERCURE, THOMAS
<b>Citation 1:</b> MISD DWLS				
<b>Log ID:</b> 698930	<b>Date:</b> 6/15/2018 11:14 PM	<b>Location:</b> FORD/CLARK	<b>Ticket #:</b>	<b>Deputy:</b> SMITH, JESSE
<b>Log ID:</b> 698930	<b>Date:</b> 6/15/2018 11:21 PM	<b>Location:</b> GEDDES/GALE	<b>Ticket #:</b> 18WD05340	<b>Deputy:</b> SMITH, JESSE
<b>Citation 1:</b> C/I speed				
<b>Log ID:</b> 698930	<b>Date:</b> 6/15/2018 11:17 PM	<b>Location:</b> GEDDES/DIXBORO	<b>Ticket #:</b>	<b>Deputy:</b> SMITH, JESSE
<b>Log ID:</b> 698930	<b>Date:</b> 6/15/2018 11:19 PM	<b>Location:</b> GEDDES/GALE	<b>Ticket #:</b>	<b>Deputy:</b> SMITH, JESSE
<b>Log ID:</b> 698930	<b>Date:</b> 6/15/2018 11:22 PM	<b>Location:</b> GEDDES/TOWSLEY	<b>Ticket #:</b>	<b>Deputy:</b> SMITH, JESSE
<b>Log ID:</b> 698954	<b>Date:</b> 6/16/2018 4:59 AM	<b>Location:</b> HARRIS AND GEDDES	<b>Ticket #:</b>	<b>Deputy:</b> BUFFA, DANIEL
<b>Log ID:</b> 698984	<b>Date:</b> 6/16/2018 12:54 PM	<b>Location:</b> BERKSHIRE/PROSPECT	<b>Ticket #:</b>	<b>Deputy:</b> ROSS, JEREMY
<b>Log ID:</b> 698997	<b>Date:</b> 6/16/2018 1:22 PM	<b>Location:</b> DAWN/ PANAMA	<b>Ticket #:</b> 18WD5342	<b>Deputy:</b> HOUK, RICHARD
<b>Citation 1:</b> C/I SPEED		<b>Citation 2:</b> C/I IMPEDED TRAFFIC		
<b>Log ID:</b> 698997	<b>Date:</b> 6/16/2018 7:08 PM	<b>Location:</b> DAWN / CLARK	<b>Ticket #:</b> N/A	<b>Deputy:</b> HOUK, RICHARD
<b>Log ID:</b> 698997	<b>Date:</b> 6/16/2018 7:16 PM	<b>Location:</b> STAMFORD / DAWN	<b>Ticket #:</b> N/A	<b>Deputy:</b> HOUK, RICHARD
<b>Log ID:</b> 698997	<b>Date:</b> 6/16/2018 2:18 PM	<b>Location:</b> CLARK /DAWN	<b>Ticket #:</b> N/A	<b>Deputy:</b> HOUK, RICHARD
<b>Log ID:</b> 699003	<b>Date:</b> 6/16/2018 10:26 PM	<b>Location:</b> PROSPECT/GEDDES	<b>Ticket #:</b>	<b>Deputy:</b> MCGRADY, PATRICK
<b>Log ID:</b> 699003	<b>Date:</b> 6/16/2018 10:28 PM	<b>Location:</b> GEDDES/HICKMAN	<b>Ticket #:</b>	<b>Deputy:</b> MCGRADY, PATRICK
<b>Log ID:</b> 699025	<b>Date:</b> 6/17/2018 3:32 AM	<b>Location:</b> PROSPECT/CLARK	<b>Ticket #:</b>	<b>Deputy:</b> FARMER HEWITT, HOLLY
<b>Log ID:</b> 699025	<b>Date:</b> 6/16/2018 5:49 PM	<b>Location:</b> GEDDES/WENDELL	<b>Ticket #:</b>	<b>Deputy:</b> FARMER HEWITT, HOLLY

**Activity Log Citation by Area Report**

<b>Log ID:</b> 699034	<b>Date:</b> 6/16/2018 11:12 PM	<b>Location:</b> CLARK/LEFOROGE	<b>Ticket #:</b> 5352	<b>Deputy:</b> SMITH, JESSE
<b>Citation 1:</b> MISD no ops		<b>Citation 2:</b> C/I disobey stop sign		
<b>Log ID:</b> 699034	<b>Date:</b> 6/16/2018 11:10 PM	<b>Location:</b> LEFORGE/CLARK	<b>Ticket #:</b>	<b>Deputy:</b> SMITH, JESSE
<b>Log ID:</b> 699034	<b>Date:</b> 6/16/2018 10:45 PM	<b>Location:</b> LEFORGE/CLARK	<b>Ticket #:</b>	<b>Deputy:</b> SMITH, JESSE
<b>Log ID:</b> 699034	<b>Date:</b> 6/17/2018 12:37 AM	<b>Location:</b> GEDDES/RIDGE	<b>Ticket #:</b>	<b>Deputy:</b> SMITH, JESSE
<b>Log ID:</b> 699034	<b>Date:</b> 6/17/2018 1:08 AM	<b>Location:</b> GEDDES/LEFORGE	<b>Ticket #:</b>	<b>Deputy:</b> SMITH, JESSE
<b>Log ID:</b> 699034	<b>Date:</b> 6/17/2018 1:22 AM	<b>Location:</b> GEDDES/GALE	<b>Ticket #:</b> 5358	<b>Deputy:</b> SMITH, JESSE
<b>Citation 1:</b> C/I insurance				
<b>Log ID:</b> 699034	<b>Date:</b> 6/17/2018 3:11 AM	<b>Location:</b> SHEFFIELD/GLENDALE	<b>Ticket #:</b>	<b>Deputy:</b> SMITH, JESSE
<b>Log ID:</b> 699034	<b>Date:</b> 6/16/2018 11:25 PM	<b>Location:</b> LEFORGE/CLARK	<b>Ticket #:</b>	<b>Deputy:</b> SMITH, JESSE
<b>Log ID:</b> 699049	<b>Date:</b> 6/17/2018 6:25 AM	<b>Location:</b> GEDDES AND ANDOVER	<b>Ticket #:</b>	<b>Deputy:</b> BUFFA, DANIEL
<b>Log ID:</b> 699099	<b>Date:</b> 6/17/2018 9:57 AM	<b>Location:</b> PROSPECT/CHERRY HILL	<b>Ticket #:</b>	<b>Deputy:</b> ROSS, JEREMY
<b>Log ID:</b> 699111	<b>Date:</b> 6/17/2018 7:30 PM	<b>Location:</b> GEDDES / HIGH MEADOW	<b>Ticket #:</b> N/A	<b>Deputy:</b> HOUK, RICHARD
<b>Log ID:</b> 699111	<b>Date:</b> 6/17/2018 2:22 PM	<b>Location:</b> DAWN / PANAMA	<b>Ticket #:</b> N/A	<b>Deputy:</b> HOUK, RICHARD
<b>Log ID:</b> 699111	<b>Date:</b> 6/17/2018 2:49 PM	<b>Location:</b> CLARK / DAWN	<b>Ticket #:</b> N/A	<b>Deputy:</b> HOUK, RICHARD
<b>Log ID:</b> 699111	<b>Date:</b> 6/17/2018 4:12 PM	<b>Location:</b> FORD / BERRY	<b>Ticket #:</b> 18WD5366	<b>Deputy:</b> HOUK, RICHARD
<b>Citation 1:</b> C/I SPEED		<b>Citation 2:</b> C/I FAIL TO DISPLAY VALID LICENSE		
<b>Log ID:</b> 699145	<b>Date:</b> 6/17/2018 9:29 PM	<b>Location:</b> GEDDES/23	<b>Ticket #:</b> 18WD05374	<b>Deputy:</b> MCGRADY, PATRICK
<b>Citation 1:</b> C/I impeding				
<b>Log ID:</b> 699145	<b>Date:</b> 6/17/2018 8:51 PM	<b>Location:</b> GEDDES/TOWSLEY	<b>Ticket #:</b>	<b>Deputy:</b> MCGRADY, PATRICK
<b>Log ID:</b> 699145	<b>Date:</b> 6/17/2018 9:45 PM	<b>Location:</b> GEDDES/DIXBORO	<b>Ticket #:</b> 18WD05375	<b>Deputy:</b> MCGRADY, PATRICK
<b>Citation 1:</b> C/I no proof insur				
<b>Log ID:</b> 699145	<b>Date:</b> 6/17/2018 9:51 PM	<b>Location:</b> GEDDES/DIXBORO	<b>Ticket #:</b>	<b>Deputy:</b> MCGRADY, PATRICK
<b>Log ID:</b> 699145	<b>Date:</b> 6/17/2018 10:19 PM	<b>Location:</b> GEDDES/DIXBORO	<b>Ticket #:</b> 18WD05376	<b>Deputy:</b> MCGRADY, PATRICK
<b>Citation 1:</b> C/I impedinig				
<b>Log ID:</b> 699145	<b>Date:</b> 6/17/2018 10:26 PM	<b>Location:</b> GEDDES/TOWSLEY	<b>Ticket #:</b>	<b>Deputy:</b> MCGRADY, PATRICK
<b>Log ID:</b> 699145	<b>Date:</b> 6/17/2018 10:58 PM	<b>Location:</b> CLARK/CENTENNIAL	<b>Ticket #:</b>	<b>Deputy:</b> MCGRADY, PATRICK
<b>Log ID:</b> 699145	<b>Date:</b> 6/17/2018 11:32 PM	<b>Location:</b> SUPERIOR/GEDDES	<b>Ticket #:</b>	<b>Deputy:</b> MCGRADY, PATRICK

**Activity Log Citation by Area Report**

<b>Log ID:</b> 699159	<b>Date:</b> 6/17/2018 11:35 PM	<b>Location:</b> GEDDES/HICKMAN	<b>Ticket #:</b> 18WD05383	<b>Deputy:</b> WALLACE, SAMUEL
<b>Citation 1:</b> C/I Other: Impeded Traffic				
<b>Log ID:</b> 699159	<b>Date:</b> 6/18/2018 12:56 AM	<b>Location:</b> PROSPECT/VREELAND	<b>Ticket #:</b>	<b>Deputy:</b> WALLACE, SAMUEL
<b>Log ID:</b> 699159	<b>Date:</b> 6/17/2018 11:22 PM	<b>Location:</b> GEDDES/TOWSLEY	<b>Ticket #:</b>	<b>Deputy:</b> WALLACE, SAMUEL
<b>Log ID:</b> 699159	<b>Date:</b> 6/17/2018 11:04 PM	<b>Location:</b> LEFORGE/CLARK	<b>Ticket #:</b> 18WD05380	<b>Deputy:</b> WALLACE, SAMUEL
<b>Citation 1:</b> MISD Registration Plate Other: Improper				
<b>Log ID:</b> 699159	<b>Date:</b> 6/17/2018 10:18 PM	<b>Location:</b> LEFORGE/HRD	<b>Ticket #:</b>	<b>Deputy:</b> WALLACE, SAMUEL
<b>Log ID:</b> 699186	<b>Date:</b> 6/18/2018 3:30 AM	<b>Location:</b> FORD/PROPSECT	<b>Ticket #:</b>	<b>Deputy:</b> FARMER HEWITT, HOLLY
<b>Log ID:</b> 699186	<b>Date:</b> 6/18/2018 3:26 AM	<b>Location:</b> PROSPECT/BELLERS	<b>Ticket #:</b>	<b>Deputy:</b> FARMER HEWITT, HOLLY
<b>Log ID:</b> 699186	<b>Date:</b> 6/18/2018 3:06 AM	<b>Location:</b> GEDDES/DIXBORO	<b>Ticket #:</b>	<b>Deputy:</b> FARMER HEWITT, HOLLY
<b>Log ID:</b> 699190	<b>Date:</b> 6/18/2018 5:42 AM	<b>Location:</b> PROSPECT/CHERRY HILL	<b>Ticket #:</b>	<b>Deputy:</b> SEXTON, DAVID
<b>Log ID:</b> 699202	<b>Date:</b> 6/18/2018 8:43 AM	<b>Location:</b> STACY LYNN PETERSON	<b>Ticket #:</b>	<b>Deputy:</b> MERCURE, THOMAS
<b>Log ID:</b> 699202	<b>Date:</b> 6/18/2018 8:55 AM	<b>Location:</b> BERKSHIRE/ WILTSHIRE	<b>Ticket #:</b>	<b>Deputy:</b> MERCURE, THOMAS
<b>Log ID:</b> 699234	<b>Date:</b> 6/18/2018 11:00 AM	<b>Location:</b> DEVON/NOTTINGHAM	<b>Ticket #:</b>	<b>Deputy:</b> ROSS, JEREMY
<b>Log ID:</b> 699234	<b>Date:</b> 6/18/2018 11:36 AM	<b>Location:</b> RIDGE/MOTT	<b>Ticket #:</b>	<b>Deputy:</b> ROSS, JEREMY
<b>Log ID:</b> 699234	<b>Date:</b> 6/18/2018 9:44 AM	<b>Location:</b> PLYMOUTH/FORD	<b>Ticket #:</b>	<b>Deputy:</b> ROSS, JEREMY
<b>Log ID:</b> 699234	<b>Date:</b> 6/18/2018 9:08 AM	<b>Location:</b> RIDGE/GEDDES	<b>Ticket #:</b>	<b>Deputy:</b> ROSS, JEREMY
<b>Log ID:</b> 699259	<b>Date:</b> 6/18/2018 7:18 PM	<b>Location:</b> SUPERIOR 1ST	<b>Ticket #:</b> N/A	<b>Deputy:</b> HOUK, RICHARD
<b>Log ID:</b> 699259	<b>Date:</b> 6/18/2018 4:04 PM	<b>Location:</b> FORD / GODFRETSON	<b>Ticket #:</b> N/A	<b>Deputy:</b> HOUK, RICHARD
<b>Log ID:</b> 699259	<b>Date:</b> 6/18/2018 2:01 PM	<b>Location:</b> DAWN / PANAMA	<b>Ticket #:</b> N/A	<b>Deputy:</b> HOUK, RICHARD
<b>Log ID:</b> 699310	<b>Date:</b> 6/18/2018 11:30 PM	<b>Location:</b> PROSPECT/VREELAND	<b>Ticket #:</b> 18WD	<b>Deputy:</b> FARMER HEWITT, HOLLY
<b>Citation 1:</b> MISD Other: unlicensed driver				
<b>Log ID:</b> 699310	<b>Date:</b> 6/18/2018 11:26 PM	<b>Location:</b> 1881 RIDGE	<b>Ticket #:</b>	<b>Deputy:</b> FARMER HEWITT, HOLLY
<b>Log ID:</b> 699370	<b>Date:</b> 6/19/2018 10:52 AM	<b>Location:</b> FORD/PROSPECT	<b>Ticket #:</b>	<b>Deputy:</b> ROSS, JEREMY
<b>Log ID:</b> 699370	<b>Date:</b> 6/19/2018 8:36 AM	<b>Location:</b> NAPIER/FORD	<b>Ticket #:</b>	<b>Deputy:</b> ROSS, JEREMY
<b>Log ID:</b> 699441	<b>Date:</b> 6/19/2018 7:02 PM	<b>Location:</b> SUPERIOR FIRST	<b>Ticket #:</b> DIGI	<b>Deputy:</b> CROVA, JOSEPH
<b>Citation 1:</b> C/I np				
<b>Log ID:</b> 699441	<b>Date:</b> 6/19/2018 4:24 PM	<b>Location:</b> SUPERIOR FIRST	<b>Ticket #:</b>	<b>Deputy:</b> CROVA, JOSEPH

**Activity Log Citation by Area Report**

<b>Log ID:</b> 699441	<b>Date:</b> 6/19/2018 4:20 PM	<b>Location:</b> SUPERIOR FIRST	<b>Ticket #:</b>	<b>Deputy:</b> CROVA, JOSEPH
<b>Log ID:</b> 699441	<b>Date:</b> 6/19/2018 4:15 PM	<b>Location:</b> SUPERIOR HRD	<b>Ticket #:</b>	<b>Deputy:</b> CROVA, JOSEPH
<b>Log ID:</b> 699441	<b>Date:</b> 6/19/2018 6:53 PM	<b>Location:</b> SUPERIOR FIRST	<b>Ticket #:</b>	<b>Deputy:</b> CROVA, JOSEPH
<b>Log ID:</b> 699490	<b>Date:</b> 6/19/2018 11:57 PM	<b>Location:</b> HRD/CORNELL	<b>Ticket #:</b> 18WD05407	<b>Deputy:</b> FARMER HEWITT, HOLLY
<b>Citation 1:</b> C/I Other: no proof insurance				
<b>Log ID:</b> 699490	<b>Date:</b> 6/19/2018 11:48 PM	<b>Location:</b> GEDDES/DIXBORO	<b>Ticket #:</b>	<b>Deputy:</b> FARMER HEWITT, HOLLY
<b>Log ID:</b> 699490	<b>Date:</b> 6/19/2018 11:17 PM	<b>Location:</b> GEDDES/DIXBORO	<b>Ticket #:</b>	<b>Deputy:</b> FARMER HEWITT, HOLLY
<b>Log ID:</b> 699584	<b>Date:</b> 6/20/2018 2:18 PM	<b>Location:</b> BERKSHIRE/ SHEFFIELD	<b>Ticket #:</b>	<b>Deputy:</b> MERCURE, THOMAS
<b>Log ID:</b> 699593	<b>Date:</b> 6/20/2018 1:39 PM	<b>Location:</b> GOTFREDSON/PLYMOUTH	<b>Ticket #:</b>	<b>Deputy:</b> ROSS, JEREMY
<b>Log ID:</b> 699599	<b>Date:</b> 6/20/2018 2:59 PM	<b>Location:</b> MACARTHUR / STAMFORD	<b>Ticket #:</b> N/A	<b>Deputy:</b> HOUK, RICHARD
<b>Log ID:</b> 699599	<b>Date:</b> 6/20/2018 4:45 PM	<b>Location:</b> PROSPECT / GEDDES	<b>Ticket #:</b> 18WD5425	<b>Deputy:</b> HOUK, RICHARD
<b>Citation 1:</b> C/I TAILGATING <b>Citation 2:</b> C/I SPEED <b>Citation3:</b> C/I IMPEDED TRAFFIC				
<b>Log ID:</b> 699599	<b>Date:</b> 6/20/2018 2:28 PM	<b>Location:</b> CLARK / DAWN	<b>Ticket #:</b> N/A	<b>Deputy:</b> HOUK, RICHARD
<b>Log ID:</b> 699599	<b>Date:</b> 6/20/2018 6:37 PM	<b>Location:</b> PLYMOUTH /DIXBORO	<b>Ticket #:</b> 18WD5427	<b>Deputy:</b> HOUK, RICHARD
<b>Citation 1:</b> C/I DEFECTIVE EQUIPMENT <b>Citation 2:</b> MISD UNREGISTERED VEHICLE <b>Citation3:</b> MISD EXPIRED LICENSE				
<b>Log ID:</b> 699663	<b>Date:</b> 6/20/2018 10:39 PM	<b>Location:</b> FORD/GOTFREDSON	<b>Ticket #:</b> 18WD05435	<b>Deputy:</b> MCGRADY, PATRICK
<b>Citation 1:</b> C/I impeding				
<b>Log ID:</b> 699663	<b>Date:</b> 6/20/2018 11:08 PM	<b>Location:</b> FORD/NAPIER	<b>Ticket #:</b>	<b>Deputy:</b> MCGRADY, PATRICK
<b>Log ID:</b> 699684	<b>Date:</b> 6/21/2018 2:07 AM	<b>Location:</b> FORD / PROSPECT	<b>Ticket #:</b> N/A	<b>Deputy:</b> HUNT, CHARLES
<b>Log ID:</b> 699684	<b>Date:</b> 6/21/2018 12:35 AM	<b>Location:</b> PROSPECT / FORD	<b>Ticket #:</b> 18WD05440	<b>Deputy:</b> HUNT, CHARLES
<b>Citation 1:</b> C/I Defective headlights <b>Citation 2:</b> C/I Other: No Proof Ins. <b>Citation3:</b> MISD No ops on person				
<b>Log ID:</b> 699693	<b>Date:</b> 6/20/2018 11:13 PM	<b>Location:</b> WIARD/CLARK	<b>Ticket #:</b>	<b>Deputy:</b> SMITH, JESSE
<b>Log ID:</b> 699693	<b>Date:</b> 6/21/2018 2:41 AM	<b>Location:</b> PROSPECT/CROSS	<b>Ticket #:</b>	<b>Deputy:</b> SMITH, JESSE
<b>Log ID:</b> 699693	<b>Date:</b> 6/21/2018 12:15 AM	<b>Location:</b> DIXBORO/GEDDES	<b>Ticket #:</b> 5439	<b>Deputy:</b> SMITH, JESSE
<b>Citation 1:</b> C/I defective headlight				
<b>Log ID:</b> 699766	<b>Date:</b> 6/21/2018 3:46 PM	<b>Location:</b> CLARK/ SWEET	<b>Ticket #:</b>	<b>Deputy:</b> WOOLLAMS, JOHNNY
<b>Log ID:</b> 699837	<b>Date:</b> 6/21/2018 8:57 PM	<b>Location:</b> MACARTHUR & HARRIS	<b>Ticket #:</b>	<b>Deputy:</b> GONTARSKI, JEFFREY
<b>Log ID:</b> 699839	<b>Date:</b> 6/22/2018 1:17 PM	<b>Location:</b> PROSPECT & CHERRY HILL	<b>Ticket #:</b>	<b>Deputy:</b> GONTARSKI, JEFFREY

## Activity Log Citation by Area Report

<b>Log ID:</b> 699851	<b>Date:</b> 6/21/2018 4:44 PM	<b>Location:</b> SHEFFIELD/BERKSHIRE	<b>Ticket #:</b>	<b>Deputy:</b> MCGRADY, PATRICK
<b>Log ID:</b> 699873	<b>Date:</b> 6/22/2018 3:41 AM	<b>Location:</b> BERKSHIRE/WHILTSHIRE	<b>Ticket #:</b>	<b>Deputy:</b> SMITH, JESSE
<b>Log ID:</b> 699873	<b>Date:</b> 6/21/2018 8:54 PM	<b>Location:</b> FORD/CLARK	<b>Ticket #:</b>	<b>Deputy:</b> SMITH, JESSE
<b>Log ID:</b> 699889	<b>Date:</b> 6/22/2018 2:22 AM	<b>Location:</b> PANAMA/STAMFORD	<b>Ticket #:</b>	<b>Deputy:</b> BUFFA, DANIEL
<b>Log ID:</b> 700058	<b>Date:</b> 6/23/2018 11:24 PM	<b>Location:</b> GEDDES/SUPERIOR	<b>Ticket #:</b> 18WD05535	<b>Deputy:</b> SMITH, JESSE
<b>Citation 1:</b> C/I child restraint				
<b>Log ID:</b> 700084	<b>Date:</b> 6/23/2018 1:17 PM	<b>Location:</b> PLYMOUTH/BERRY	<b>Ticket #:</b>	<b>Deputy:</b> ROSS, JEREMY
<b>Log ID:</b> 700084	<b>Date:</b> 6/23/2018 1:34 PM	<b>Location:</b> GEDDES/GALE	<b>Ticket #:</b>	<b>Deputy:</b> ROSS, JEREMY
<b>Log ID:</b> 700084	<b>Date:</b> 6/23/2018 1:57 PM	<b>Location:</b> STAMFORD/WIARD	<b>Ticket #:</b>	<b>Deputy:</b> ROSS, JEREMY
<b>Log ID:</b> 700099	<b>Date:</b> 6/23/2018 7:36 PM	<b>Location:</b> DAWN / PANAMA	<b>Ticket #:</b> N/A	<b>Deputy:</b> HOUK, RICHARD
<b>Log ID:</b> 700099	<b>Date:</b> 6/23/2018 7:54 PM	<b>Location:</b> DAWN/ PANAMA	<b>Ticket #:</b> 18WD5529	<b>Deputy:</b> HOUK, RICHARD
<b>Citation 1:</b> C/I SPEED <span style="margin-left: 150px;"><b>Citation 2:</b> C/I IMPEDED TRAFFIC</span> <span style="margin-left: 150px;"><b>Citation3:</b> MISD FAIL TO DISPLAY VALID LICENSE</span>				
<b>Log ID:</b> 700217	<b>Date:</b> 6/24/2018 11:45 AM	<b>Location:</b> STAMFORD/STEPHENS	<b>Ticket #:</b>	<b>Deputy:</b> ROSS, JEREMY
<b>Log ID:</b> 700217	<b>Date:</b> 6/24/2018 3:36 PM	<b>Location:</b> PROSPECT/GEDDES	<b>Ticket #:</b>	<b>Deputy:</b> ROSS, JEREMY
<b>Log ID:</b> 700230	<b>Date:</b> 6/24/2018 8:49 PM	<b>Location:</b> PROSPECT / AUTUM WOODS	<b>Ticket #:</b> N/A	<b>Deputy:</b> HOUK, RICHARD
<b>Log ID:</b> 700230	<b>Date:</b> 6/24/2018 3:31 PM	<b>Location:</b> GEDDES / GALE	<b>Ticket #:</b> 18WD5545	<b>Deputy:</b> HOUK, RICHARD
<b>Citation 1:</b> C/I SPEED <span style="margin-left: 150px;"><b>Citation 2:</b> C/I IMPEDED TRAFFIC</span>				
<b>Log ID:</b> 700230	<b>Date:</b> 6/24/2018 8:49 PM	<b>Location:</b> DAWN / CLARK	<b>Ticket #:</b> N/A	<b>Deputy:</b> HOUK, RICHARD
<b>Log ID:</b> 700264	<b>Date:</b> 6/24/2018 11:23 PM	<b>Location:</b> BERKSHIRE/PROSPECT	<b>Ticket #:</b>	<b>Deputy:</b> MCGRADY, PATRICK
<b>Log ID:</b> 700273	<b>Date:</b> 6/25/2018 3:37 AM	<b>Location:</b> PROSPECT/BELLERS T	<b>Ticket #:</b>	<b>Deputy:</b> FARMER HEWITT, HOLLY
<b>Log ID:</b> 700273	<b>Date:</b> 6/25/2018 3:29 AM	<b>Location:</b> DIXBORO/PLYMOUTH	<b>Ticket #:</b> 18WD	<b>Deputy:</b> FARMER HEWITT, HOLLY
<b>Citation 1:</b> C/I License & Registration				
<b>Log ID:</b> 700315	<b>Date:</b> 6/25/2018 10:47 AM	<b>Location:</b> BERKSHIRE/ WILTSHIRE	<b>Ticket #:</b>	<b>Deputy:</b> MERCURE, THOMAS
<b>Log ID:</b> 700315	<b>Date:</b> 6/25/2018 11:02 AM	<b>Location:</b> BERKSHIRE/ WILTSHIRE	<b>Ticket #:</b>	<b>Deputy:</b> MERCURE, THOMAS
<b>Log ID:</b> 700315	<b>Date:</b> 6/25/2018 8:41 AM	<b>Location:</b> BERKSHIRE/ WILTSHIRE	<b>Ticket #:</b>	<b>Deputy:</b> MERCURE, THOMAS
<b>Log ID:</b> 700315	<b>Date:</b> 6/25/2018 9:12 AM	<b>Location:</b> BERKSHIRE/ WILTSHIRE	<b>Ticket #:</b> 18WD05551	<b>Deputy:</b> MERCURE, THOMAS
<b>Citation 1:</b> C/I SPEED				
<b>Log ID:</b> 700430	<b>Date:</b> 6/26/2018 12:16 AM	<b>Location:</b> GEDDES / HICKMAN	<b>Ticket #:</b> N/A	<b>Deputy:</b> HUNT, CHARLES



**Activity Log Citation by Area Report**

<b>Log ID:</b> 700460	<b>Date:</b> 6/26/2018 3:59 AM	<b>Location:</b> CLARK/RIVER	<b>Ticket #:</b>	<b>Deputy:</b> FARMER HEWITT, HOLLY
<b>Log ID:</b> 700464	<b>Date:</b> 6/26/2018 5:16 AM	<b>Location:</b> PROSPECT/ GEDDES	<b>Ticket #:</b>	<b>Deputy:</b> MERCURE, THOMAS
<b>Log ID:</b> 700499	<b>Date:</b> 6/26/2018 10:37 AM	<b>Location:</b> PROSPECT/FORD	<b>Ticket #:</b>	<b>Deputy:</b> ROSS, JEREMY
<b>Log ID:</b> 700499	<b>Date:</b> 6/26/2018 8:16 AM	<b>Location:</b> PROSPECT/GEDDES	<b>Ticket #:</b>	<b>Deputy:</b> ROSS, JEREMY
<b>Log ID:</b> 700499	<b>Date:</b> 6/26/2018 9:27 AM	<b>Location:</b> BERKSHIRE/WILTSHIRE	<b>Ticket #:</b>	<b>Deputy:</b> ROSS, JEREMY
<b>Log ID:</b> 700506	<b>Date:</b> 6/26/2018 1:48 PM	<b>Location:</b> BERKSHIRE/ SHEFFIELD	<b>Ticket #:</b> 18WD05590	<b>Deputy:</b> MERCURE, THOMAS
<b>Citation 1:</b> C/I SPEED				
<b>Log ID:</b> 700506	<b>Date:</b> 6/26/2018 12:43 PM	<b>Location:</b> BERKSHIRE/ WILTSHIRE	<b>Ticket #:</b>	<b>Deputy:</b> MERCURE, THOMAS
<b>Log ID:</b> 700506	<b>Date:</b> 6/26/2018 9:36 AM	<b>Location:</b> SUPERIOR/ FIRST	<b>Ticket #:</b> 18WD05576	<b>Deputy:</b> MERCURE, THOMAS
<b>Citation 1:</b> C/I IMPED				
<b>Log ID:</b> 700506	<b>Date:</b> 6/26/2018 2:09 PM	<b>Location:</b> BERKSHIRE/ SHEFFIELD	<b>Ticket #:</b>	<b>Deputy:</b> MERCURE, THOMAS
<b>Log ID:</b> 700506	<b>Date:</b> 6/26/2018 3:07 PM	<b>Location:</b> PLYMOUTH/ CHURCH	<b>Ticket #:</b> 18WD05595	<b>Deputy:</b> MERCURE, THOMAS
<b>Citation 1:</b> C/I BRAKE LAMP				
<b>Log ID:</b> 700527	<b>Date:</b> 6/26/2018 12:53 PM	<b>Location:</b> DAWN / PANAMA	<b>Ticket #:</b> 18WD5588	<b>Deputy:</b> HOUK, RICHARD
<b>Citation 1:</b> C/I SPEED <b>Citation 2:</b> C/I IMPEDED TRAFFIC				
<b>Log ID:</b> 700527	<b>Date:</b> 6/26/2018 12:43 PM	<b>Location:</b> DAWN / PANAMA	<b>Ticket #:</b> N/A	<b>Deputy:</b> HOUK, RICHARD
<b>Log ID:</b> 700602	<b>Date:</b> 6/27/2018 12:22 AM	<b>Location:</b> GEDDES/PROSPECT	<b>Ticket #:</b>	<b>Deputy:</b> WALLACE, SAMUEL
<b>Log ID:</b> 700602	<b>Date:</b> 6/27/2018 2:30 AM	<b>Location:</b> LEFORGE AND CLARK	<b>Ticket #:</b>	<b>Deputy:</b> WALLACE, SAMUEL
<b>Log ID:</b> 700602	<b>Date:</b> 6/27/2018 1:45 AM	<b>Location:</b> LEFORDGE AND CLARK	<b>Ticket #:</b>	<b>Deputy:</b> WALLACE, SAMUEL
<b>Log ID:</b> 700621	<b>Date:</b> 6/27/2018 7:43 AM	<b>Location:</b> FORD AND OLD FORD	<b>Ticket #:</b>	<b>Deputy:</b> BUFFA, DANIEL
<b>Log ID:</b> 700750	<b>Date:</b> 6/27/2018 11:10 PM	<b>Location:</b> DIXBORO/PLYMOUTH	<b>Ticket #:</b>	<b>Deputy:</b> FARMER HEWITT, HOLLY
<b>Log ID:</b> 700750	<b>Date:</b> 6/27/2018 11:07 PM	<b>Location:</b> BERKSHIRE/STEPHENS	<b>Ticket #:</b>	<b>Deputy:</b> FARMER HEWITT, HOLLY
<b>Log ID:</b> 700750	<b>Date:</b> 6/27/2018 5:17 PM	<b>Location:</b> RIDGE/SCARLET OAK	<b>Ticket #:</b> 18WD05646	<b>Deputy:</b> FARMER HEWITT, HOLLY
<b>Citation 1:</b> MISD Suspended/revoked ops				
<b>Log ID:</b> 700754	<b>Date:</b> 6/27/2018 5:54 PM	<b>Location:</b> 510 PROSPECT	<b>Ticket #:</b>	<b>Deputy:</b> FARMER HEWITT, HOLLY
<b>Log ID:</b> 700754	<b>Date:</b> 6/27/2018 10:31 PM	<b>Location:</b> CLARK/PROSPECT	<b>Ticket #:</b> 18WD	<b>Deputy:</b> FARMER HEWITT, HOLLY
<b>Citation 1:</b> C/I Other: no proof insurance				
<b>Log ID:</b> 700785	<b>Date:</b> 6/28/2018 6:27 AM	<b>Location:</b> FORD AND OLD FORD	<b>Ticket #:</b>	<b>Deputy:</b> BUFFA, DANIEL
<b>Log ID:</b> 700785	<b>Date:</b> 6/28/2018 7:08 AM	<b>Location:</b> LEFORGE AND GEDDES	<b>Ticket #:</b>	<b>Deputy:</b> BUFFA, DANIEL

**Activity Log Citation by Area Report**

<b>Log ID:</b> 700817	<b>Date:</b> 6/28/2018 11:23 AM	<b>Location:</b> BERKSHIRE/ SHEFFIELD	<b>Ticket #:</b>	<b>Deputy:</b> MERCURE, THOMAS
<b>Log ID:</b> 700817	<b>Date:</b> 6/28/2018 12:07 PM	<b>Location:</b> BERKSHIRE/ SHEFFIELD	<b>Ticket #:</b>	<b>Deputy:</b> MERCURE, THOMAS
<b>Log ID:</b> 700817	<b>Date:</b> 6/28/2018 11:42 AM	<b>Location:</b> BERKSHIRE/ SHEFFIELD	<b>Ticket #:</b> 18WD05686	<b>Deputy:</b> MERCURE, THOMAS
<b>Citation 1:</b> MISD NO OPS		<b>Citation 2:</b> C/I BRAKE LAMP		
<b>Log ID:</b> 700817	<b>Date:</b> 6/28/2018 12:59 PM	<b>Location:</b> BERKSHIRE/ SHEFFIELD	<b>Ticket #:</b>	<b>Deputy:</b> MERCURE, THOMAS
<b>Log ID:</b> 700817	<b>Date:</b> 6/28/2018 12:38 PM	<b>Location:</b> BERKSHIRE/ SHEFFIELD	<b>Ticket #:</b>	<b>Deputy:</b> MERCURE, THOMAS
<b>Log ID:</b> 700927	<b>Date:</b> 6/28/2018 5:56 PM	<b>Location:</b> FORD & OLD FORD	<b>Ticket #:</b>	<b>Deputy:</b> GONTARSKI, JEFFREY
<b>Log ID:</b> 700931	<b>Date:</b> 6/28/2018 7:47 PM	<b>Location:</b> SUPERIOR / GEDDES	<b>Ticket #:</b> N/A	<b>Deputy:</b> HUNT, CHARLES
<b>Log ID:</b> 700947	<b>Date:</b> 6/28/2018 10:59 PM	<b>Location:</b> GEDDES/TOWSLEY	<b>Ticket #:</b>	<b>Deputy:</b> SMITH, JESSE
<b>Log ID:</b> 700947	<b>Date:</b> 6/28/2018 10:36 PM	<b>Location:</b> GEDDES/DIXBORO	<b>Ticket #:</b>	<b>Deputy:</b> SMITH, JESSE
<b>Log ID:</b> 700947	<b>Date:</b> 6/28/2018 9:45 PM	<b>Location:</b> GEDDES/PROSPECT	<b>Ticket #:</b>	<b>Deputy:</b> SMITH, JESSE
<b>Log ID:</b> 700963	<b>Date:</b> 6/29/2018 1:59 AM	<b>Location:</b> CLARK/GOLFSIDE	<b>Ticket #:</b>	<b>Deputy:</b> BUFFA, DANIEL
<b>Log ID:</b> 701037	<b>Date:</b> 6/29/2018 11:39 AM	<b>Location:</b> BERKSHIRE/ SHEFFIELD	<b>Ticket #:</b> 18WD05728	<b>Deputy:</b> MERCURE, THOMAS
<b>Citation 1:</b> C/I INSURANCE				
<b>Log ID:</b> 701037	<b>Date:</b> 6/29/2018 12:09 PM	<b>Location:</b> BERKSHIRE/ SHEFFIELD	<b>Ticket #:</b>	<b>Deputy:</b> MERCURE, THOMAS
<b>Log ID:</b> 701133	<b>Date:</b> 6/29/2018 10:42 PM	<b>Location:</b> CLARK/MACARTHUR	<b>Ticket #:</b>	<b>Deputy:</b> SMITH, JESSE
<b>Log ID:</b> 701133	<b>Date:</b> 6/29/2018 10:40 PM	<b>Location:</b> GEDDES/PROSPECT	<b>Ticket #:</b>	<b>Deputy:</b> SMITH, JESSE
<b>Log ID:</b> 701137	<b>Date:</b> 6/30/2018 2:36 AM	<b>Location:</b> PROSPECT / CLARK	<b>Ticket #:</b> 18WD05762	<b>Deputy:</b> KRINGS, NICHOLAS
<b>Citation 1:</b> C/I Disobey traff signal				
<b>Log ID:</b> 701143	<b>Date:</b> 6/30/2018 1:46 AM	<b>Location:</b> GEDDES/ARBOR WOODS	<b>Ticket #:</b>	<b>Deputy:</b> BUFFA, DANIEL
<b>Log ID:</b> 701153	<b>Date:</b> 6/30/2018 9:32 AM	<b>Location:</b> PLYMOUTH/OLD FORD	<b>Ticket #:</b>	<b>Deputy:</b> ROSS, JEREMY
<b>Log ID:</b> 701153	<b>Date:</b> 6/30/2018 11:53 AM	<b>Location:</b> STAMFORD/BERKSHIRE	<b>Ticket #:</b>	<b>Deputy:</b> ROSS, JEREMY
<b>Log ID:</b> 701178	<b>Date:</b> 6/30/2018 5:48 PM	<b>Location:</b> PROSPECT / CLARK	<b>Ticket #:</b> N/A	<b>Deputy:</b> HOUK, RICHARD
<b>Log ID:</b> 701178	<b>Date:</b> 6/30/2018 12:32 PM	<b>Location:</b> DAWN / CLARK	<b>Ticket #:</b> N/A	<b>Deputy:</b> HOUK, RICHARD
<b>Log ID:</b> 701178	<b>Date:</b> 6/30/2018 12:09 PM	<b>Location:</b> CLARK / DAWN	<b>Ticket #:</b> N/A	<b>Deputy:</b> HOUK, RICHARD
<b>Log ID:</b> 701178	<b>Date:</b> 6/30/2018 11:43 AM	<b>Location:</b> DAWN / CLARK	<b>Ticket #:</b> N/A	<b>Deputy:</b> HOUK, RICHARD
<b>Log ID:</b> 701178	<b>Date:</b> 6/30/2018 7:04 PM	<b>Location:</b> PROSPECT / CLARK	<b>Ticket #:</b> 18WD5776	<b>Deputy:</b> HOUK, RICHARD
<b>Citation 1:</b> C/I IMPEDED TRAFFIC		<b>Citation 2:</b> C/I STOP SIGN		
<b>Log ID:</b> 701228	<b>Date:</b> 6/30/2018 10:32 PM	<b>Location:</b> MACARTHUR /HEATHER	<b>Ticket #:</b>	<b>Deputy:</b> FARMER HEWITT, HOLLY

Activity Log Citation by Area Report

Log ID: 701228	Date: 6/30/2018 10:37 PM	Location: PROSPECT/FORD	Ticket #:	Deputy: FARMER HEWITT, HOLLY
Log ID: 701228	Date: 6/30/2018 7:42 PM	Location: PROPSECT/GEDDES	Ticket #:	Deputy: FARMER HEWITT, HOLLY
Log ID: 701237	Date: 6/30/2018 6:17 PM	Location: GEDDES/DIXBORO	Ticket #:	Deputy: MCGRADY, PATRICK

Total Traffic Stops: 319

Total Citations Issued: 109

Total Citation 1s: 77

Total Citation 2s: 24

Total Citation 3s: 8

Tickets Not Issued: 242

Traffic stops that ended in an arrest: 2



# Washtenaw County Sheriff's Activity Log

**Area:** 142

AA/SUT: DDACTS Zone 2 -  
MacArthur Blvd

**Date Range:** 6/1/2018 - 6/30/2018

## Activity Log Citation by Area Report

<b>Log ID:</b> 697452	<b>Date:</b> 6/6/2018 9:55 PM	<b>Location:</b> MACARTHUR/ CLARK	<b>Ticket #:</b>	<b>Deputy:</b> WOOLLAMS, JOHNNY
<b>Log ID:</b> 698016	<b>Date:</b> 6/10/2018 5:14 PM	<b>Location:</b> PANAMA/ STAMFORD	<b>Ticket #:</b>	<b>Deputy:</b> WOOLLAMS, JOHNNY
<b>Log ID:</b> 699106	<b>Date:</b> 6/17/2018 6:25 PM	<b>Location:</b> ANDOER/ GEDDES	<b>Ticket #:</b>	<b>Deputy:</b> WOOLLAMS, JOHNNY
<b>Log ID:</b> 699106	<b>Date:</b> 6/17/2018 3:07 PM	<b>Location:</b> PANAMA/ STAMFORD	<b>Ticket #:</b>	<b>Deputy:</b> WOOLLAMS, JOHNNY
<b>Log ID:</b> 699766	<b>Date:</b> 6/21/2018 4:31 PM	<b>Location:</b> MACARTHUR/ HARRIS	<b>Ticket #:</b>	<b>Deputy:</b> WOOLLAMS, JOHNNY
<b>Log ID:</b> 699766	<b>Date:</b> 6/21/2018 2:27 PM	<b>Location:</b> STAMFORD/ MACARTHUR	<b>Ticket #:</b>	<b>Deputy:</b> WOOLLAMS, JOHNNY
<b>Log ID:</b> 700019	<b>Date:</b> 6/22/2018 8:22 PM	<b>Location:</b> 9318 MACARTHUR BLVD	<b>Ticket #:</b>	<b>Deputy:</b> WOOLLAMS, JOHNNY
<b>Log ID:</b> 700146	<b>Date:</b> 6/23/2018 11:30 PM	<b>Location:</b> MACARTHUR/ DEERING	<b>Ticket #:</b> 18WD05536	<b>Deputy:</b> WOOLLAMS, JOHNNY
<b>Citation 1:</b> MISD EXP. LICENSE				
<b>Log ID:</b> 700146	<b>Date:</b> 6/23/2018 10:20 PM	<b>Location:</b> GEDDES/ HARRIS	<b>Ticket #:</b> 18WD05532	<b>Deputy:</b> WOOLLAMS, JOHNNY
<b>Citation 1:</b> MISD DWLS				
<b>Log ID:</b> 700235	<b>Date:</b> 6/24/2018 4:51 PM	<b>Location:</b> MACARTHUR/ STAMFORD	<b>Ticket #:</b> 18WD05546	<b>Deputy:</b> WOOLLAMS, JOHNNY
<b>Citation 1:</b> MISD DWLS				
<b>Log ID:</b> 700727	<b>Date:</b> 6/27/2018 8:56 PM	<b>Location:</b> MACARTHUR/ HEATHER	<b>Ticket #:</b> 18ED05652	<b>Deputy:</b> WOOLLAMS, JOHNNY
<b>Citation 1:</b> MISD NO INSURANCE				
<b>Log ID:</b> 700727	<b>Date:</b> 6/27/2018 9:48 PM	<b>Location:</b> HARRIS/ GEDDES	<b>Ticket #:</b>	<b>Deputy:</b> WOOLLAMS, JOHNNY

**Total Traffic Stops:** 12

**Total Citations Issued: 4**

**Total Citation 1s: 4**

**Total Citation 2s: 0**

**Total Citation 3s: 0**

**Tickets Not Issued: 8**

**Traffic stops that ended in an arrest: 1**



# Washtenaw County Sheriff's Activity Log

Assist Into Unassigned Area Report (Sorted by Date/Time, then Log ID)

07/03/2018

12:00 AM

Assistance Into Area: **Superior Twp.**

6/1/2018 - 6/30/2018

Log #	Deputy ID / Name	Date/Time	Type
696861	797 KITTLE, BRIAN	6/3/2018 8:00 AM	Service Request Assist
<b>Location:</b> 1515 RIDGE 265		<b>Minutes:</b> 15	<b>Assignment Area:</b> Ypsilanti Twp
<b>Comments:</b> Secure, Cleared to assist by Sgt Campbell		Assist Into: Superior Twp.	
697120	2171 BEEVER, JESSE	6/5/2018 12:40 AM	Service Request Assist
<b>Location:</b> 9310 MACARTHUR		<b>Minutes:</b> 10	<b>Assignment Area:</b> Ypsilanti Twp
<b>Comments:</b> ASSIST ON VEHICLE SEARCH PER SGT HUNT		Assist Into: Superior Twp.	
697320	549 SMITH, KENNITH	6/6/2018 6:20 AM	Service Request Assist
<b>Location:</b> 5301 E.HURON RIVER DR		<b>Minutes:</b> 25	<b>Assignment Area:</b> Ypsilanti Twp
<b>Comments:</b> ASSIST 767 W/FELONY ARREST FROM ST JOE ER/PER SGT HOY		Assist Into: Superior Twp.	
697858	1952 PELTIER, LAUREN	6/9/2018 11:45 AM	Service Requests
<b>Location:</b> GEDDES / RIDGE		<b>Minutes:</b> 25	<b>Assignment Area:</b> Ypsilanti Twp
<b>Comments:</b> per Sgt. Gieske / UTL		Assist Into: Superior Twp.	
697998	1137 RISHA, MATTHEW	6/10/2018 8:10 AM	Service Request Assist
<b>Location:</b> 10101 PLYMOUTH		<b>Minutes:</b> 30	<b>Assignment Area:</b> Salem Twp
<b>Comments:</b> Disp: Assisted Deputy Buffa on open door with alarm. Accidental set off-Sgt. Campbell approved back up		Assist Into: Superior Twp.	
698252	2295 PEARSON, AUSTIN	6/12/2018 3:45 AM	Service Requests
<b>Location:</b> 9134 MACARTHUR BLVD		<b>Minutes:</b> 30	<b>Assignment Area:</b> Ypsilanti Twp
<b>Comments:</b> CFS; APPROVED BY SGT MAHALICK		Assist Into: Superior Twp.	
698254	797 KITTLE, BRIAN	6/12/2018 3:50 AM	Service Requests
<b>Location:</b> 9138 MACARTHUR BLVD		<b>Minutes:</b> 25	<b>Assignment Area:</b> Ypsilanti Twp
<b>Comments:</b> CFS Cleared to assist by Sgt Mahalick		Assist Into: MacArthur Blvd Contract	
698267	736 KOVACH, EDWARD	6/12/2018 6:55 AM	Self-Initiated Activity
<b>Location:</b> 8608 MACARTHUR		<b>Minutes:</b> 20	<b>Assignment Area:</b> Ypsilanti Twp
<b>Comments:</b> 8608 MACARTHUR WELFARE CHECK ASST 767 18-44811		Assist Into: Superior Twp.	
698604	1714 YEE, RAY	6/14/2018 5:30 AM	Service Request Assist
<b>Location:</b> 8888 MACARTHUR		<b>Minutes:</b> 150	<b>Assignment Area:</b> Ypsilanti Twp
<b>Comments:</b> 18-45426 PER SGT KRINGS		Assist Into: MacArthur Blvd Contract	
699032	2171 BEEVER, JESSE	6/17/2018 3:15 AM	Service Request Assist
<b>Location:</b> MCARTHUR BLVD		<b>Minutes:</b> 15	<b>Assignment Area:</b> Ypsilanti Twp
<b>Comments:</b> DISP: ASSIST 768 WITH LARGE LOUD PARTY O K PER SGT. MAHALICK		Assist Into: Superior Twp.	
699182	1693 WILLIAMS, SCOTT	6/18/2018 1:10 AM	Service Request Assist
<b>Location:</b> 8860 MACARTHUR BLVD		<b>Minutes:</b> 50	<b>Assignment Area:</b> Ypsilanti Twp
<b>Comments:</b> ASSIST ON BLVD		Assist Into: MacArthur Blvd Contract	
567384	1690 MORRISON, HEATHER	6/19/2018 5:00 AM	Service Request Assist
<b>Location:</b> 9256 MACARTHUR		<b>Minutes:</b> 40	<b>Assignment Area:</b> Ypsilanti Twp



# Washtenaw County Sheriff's Activity Log

Assist Into Unassigned Area Report (Sorted by Date/Time, then Log ID)

07/03/2018

Assistance Into Area: **Superior Twp.**

12:00 AM

6/1/2018 - 6/30/2018

Log #	Deputy ID / Name	Date/Time	Type
<b>Comments:</b> assist 767 per 428			Assist Into: MacArthur Blvd Contract
699410	1355 LARKIN, ERIN	6/19/2018 4:25 PM	Service Request Assist
<b>Location:</b>	9170 MACARTHUR BLVD	<b>Minutes:</b> 15	<b>Assignment Area:</b> Ypsilanti Twp
<b>Comments:</b> DISP: ASSIST 767			Assist Into: MacArthur Blvd Contract
699741	2087 ROBERTS, BRANDON	6/21/2018 12:30 PM	Service Request Assist
<b>Location:</b>	AVONDALE/WEXFORD	<b>Minutes:</b> 35	<b>Assignment Area:</b> Ypsilanti Twp
<b>Comments:</b> Sgt. Fox approved; checked area, UTL/GOA			Assist Into: Superior Twp.
699905	2221 RUSSELL, TYREESE	6/22/2018 4:30 AM	Service Request Assist
<b>Location:</b>	SAWN / STAMFORD	<b>Minutes:</b> 15	<b>Assignment Area:</b> Ypsilanti Twp
<b>Comments:</b> ONLY SUPERIOR CAR AT HOSPITAL ON DV / ASSIST DEP MONTGOMERY / TOT HVA			Assist Into: Superior Twp.
700182	2221 RUSSELL, TYREESE	6/24/2018 6:00 AM	Service Request Assist
<b>Location:</b>	4373 FORD RD	<b>Minutes:</b> 60	<b>Assignment Area:</b> Ypsilanti Twp
<b>Comments:</b> ONLY AA TOWNSHIP DEPUTY TIED UP ON STOP / MAN WITH AX TRYING TO ATTACK BROTHER / MAINTAIN SCENE UNTIL DEPUTY WAS AVAILIABLE			Assist Into: Ann Arbor Twp.
700407	2170 TRASKOS, RICHARD	6/25/2018 5:10 PM	Service Requests
<b>Location:</b>	1515 RIDGE	<b>Minutes:</b> 60	<b>Assignment Area:</b> Ypsilanti Twp
<b>Comments:</b> EDP SUBJECT REQUESTED ME FOR TRANSPORT TO PES UOFM			Assist Into: Superior Twp.
700512	1654 GUYNES, THOMAS	6/26/2018 2:50 PM	Service Request Assist
<b>Location:</b>	PROSPECT/CLARD	<b>Minutes:</b> 10	<b>Assignment Area:</b> Ypsilanti Twp
<b>Comments:</b> ASST TO 7K91 S1 IN CUSTODY 623 AWARE			Assist Into: Superior Twp.
701006	981 WIESE, DEREK	6/29/2018 10:45 AM	Service Request Assist
<b>Location:</b>	1243 STAMFORD CT	<b>Minutes:</b> 50	<b>Assignment Area:</b> Ypsilanti Twp
<b>Comments:</b> DISPO: UNFOUNDED			Assist Into: MacArthur Blvd Contract

<b>Total Minutes:</b>	<b>680</b>	<b>( 11 hours 20 minutes )</b>
-----------------------	------------	--------------------------------

Salem Twp	1	trip totaling	30 minutes
Ypsilanti Twp	18	trips totaling	650 minutes
<b>Total:</b>	<b>19</b>	<b>trips totaling</b>	<b>680 minutes</b>

## Superior Twp - Burglary Alarms

AGENCY	INCIDENT NO.	STREET NAME	TYPE OF CALL	REPORT DATE
WCSO	180048346	7518 MYRTLE CT, SUPERIOR TWP, MI, 48198	Burglary	20180624
WCSO	180048119	5950 WARREN RD, SUPERIOR TWP, MI, 48198	Burglary	20180623
WCSO	180046732	8530 OLD OAK DR, SUPERIOR TWP, MI, 48198	Burglary	20180618
WCSO	180046725	8425 BARRINGTON DR, SUPERIOR TWP, MI, 48198	Burglary	20180618
WCSO	180046718	5477 W CLARK RD, SUPERIOR TWP, MI, 48198	Burglary	20180618
WCSO	180046448	8447 BERKSHIRE DR, SUPERIOR TWP, MI, 48198	Burglary	20180617
WCSO	180046407	6739 FLEMING CREEK DR, SUPERIOR TWP, MI, 48198	Burglary	20180617
WCSO	180043706	1900 PROSPECT RD, SUPERIOR TWP, MI, 48198	Burglary	20180608
WCSO	180042433	8314 LAKEVIEW DR, SUPERIOR TWP, MI, 48198	Burglary	20180604

## Superior Twp - Open Alarms

AGENCY	INCIDENT NO.	STREET NAME	TYPE OF CALL	REPORT DATE
WCSO	180047689	8425 BARRINGTON DR, SUPERIOR TWP, MI, 48198	Open	20180621
WCSO	180047401	3895 ALBERT RD, SUPERIOR TWP, MI, 48198	Open	20180620

## Superior Twp - Panic Alarms

WCSO	180049945	1739 SHEFFIELD DR, SUPERIOR TWP, MI, 48198	Panic	20180629
WCSO	180049425	1735 HAMLET DR, SUPERIOR TWP, MI, 48198	Panic	20180628
WCSO	180042329	2065 SHEFFIELD DR, SUPERIOR TWP, MI, 48198	Panic	20180603
WCSO	180041867	5417 WALDENHILL CT, SUPERIOR TWP, MI, 48198	Panic	20180601





# Washtenaw County Sheriff's Activity Log

07/03/2018

## Activity Log Area Summary Report

8:03 AM

Area: Superior Twp.  
Date Range: 6/1/2018 - 6/30/2018

CSO/ACO/Support Staff Log	Total Administrative Duty:	5 for a total of	282 minutes
	Total Follow Up:	2 for a total of	85 minutes
	Total Proactive Patrol:	15 for a total of	609 minutes
	Total Service Request:	6 for a total of	311 minutes
	<b>Total # of Activities:</b>	<b>28 for a total of</b>	<b>1287 minutes</b>
Deputy Log	Total Administrative Duty:	356 for a total of	10735 minutes
	Total Briefing:	105 for a total of	2260 minutes
	Total Court (Regular Time):	1 for a total of	145 minutes
	Total Community Relations:	13 for a total of	380 minutes
	Total Court Off-Duty:	2 for a total of	450 minutes
	Total Deputy Join Shift:	29 for a total of	0 minutes
	Total Deputy Left Shift:	30 for a total of	0 minutes
	Total Follow Up:	85 for a total of	4830 minutes
	Total Out of Service:	12 for a total of	30 minutes
	Total Property Check:	119 for a total of	2455 minutes
	Total Proactive Patrol:	479 for a total of	11830 minutes
	Total Special Detail:	3 for a total of	175 minutes
	Total Selective Enforcement:	174 for a total of	4420 minutes
	Total Self-Initiated Activity:	23 for a total of	635 minutes
	Total SM:	100 for a total of	2665 minutes
	Total Service Request:	341 for a total of	14980 minutes
	Total Service Request Assist:	41 for a total of	1440 minutes
	Total Training:	5 for a total of	215 minutes
	Total Traffic Stop:	312 for a total of	4665 minutes
	Total Other:	9 for a total of	230 minutes
<b>Total # of Activities:</b>	<b>2239 for a total of</b>	<b>62540 minutes</b>	
Detective Log	Total Administrative Duty:	1 for a total of	90 minutes
	Total Briefing:	1 for a total of	15 minutes
	Total Court (Regular Time):	1 for a total of	240 minutes
	Total Follow Up:	13 for a total of	1565 minutes
	Total Property Check:	1 for a total of	15 minutes
	Total Proactive Patrol:	4 for a total of	100 minutes
	Total SM:	1 for a total of	25 minutes
	Total Service Request:	1 for a total of	20 minutes
	<b>Total # of Activities:</b>	<b>23 for a total of</b>	<b>2070 minutes</b>

General Fund Patrol	Total Administrative Duty:	1 for a total of	120 minutes
	<b>Total # of Activities:</b>	<b>1 for a total of</b>	<b>120 minutes</b>
Secondary Road Patrol Log	Total Proactive Patrol:	1 for a total of	20 minutes
	Total Service Request:	1 for a total of	65 minutes
	<b>Total # of Activities:</b>	<b>2 for a total of</b>	<b>85 minutes</b>
Supervisor Log	Total Administrative Duty:	96 for a total of	4450 minutes
	Total Briefing:	23 for a total of	465 minutes
	Total Community Relations:	9 for a total of	85 minutes
	Total Follow Up:	1 for a total of	15 minutes
	Total Out of Service:	18 for a total of	0 minutes
	Total Property Check:	13 for a total of	130 minutes
	Total Proactive Patrol:	69 for a total of	1000 minutes
	Total Self-Initiated Activity:	1 for a total of	150 minutes
	Total Service Request:	3 for a total of	75 minutes
	Total Service Request Assist:	15 for a total of	455 minutes
	Total Traffic Stop:	7 for a total of	95 minutes
	<b>Total # of Activities:</b>	<b>255 for a total of</b>	<b>6920 minutes</b>
	<b>Total Superior Twp.:</b>	<b>2548 for a total of</b>	<b>73022 minutes ( 1217 hours 2 minutes)</b>



# Washtenaw County Sheriff's Activity Log

07/03/2018

## Activity Log Area Summary Report

8:03 AM

Area: AA/SUT: DDACTS Zone 1 - Oakbrook Park  
Date Range: 6/1/2018 - 6/30/2018

Deputy Log	Total Proactive Patrol:	20 for a total of	785 minutes
	<b>Total # of Activities:</b>	<b>20 for a total of</b>	<b>785 minutes</b>
	<b>Total AA/SUT: DDACTS Zone 1 - Oakbrook Park:</b>	<b>20 for a total of</b>	<b>785 minutes ( 13 hours 5 minutes)</b>



# Washtenaw County Sheriff's Activity Log

07/03/2018

## Activity Log Area Summary Report

8:03 AM

Area: AA/SUT: DDACTS Zone 2 - MacArthur Blvd  
Date Range: 6/1/2018 - 6/30/2018

Deputy Log	Total Property Check:	2 for a total of	80 minutes
	Total Proactive Patrol:	80 for a total of	2700 minutes
	Total Selective Enforcement:	1 for a total of	20 minutes
	Total Service Request:	1 for a total of	15 minutes
	Total Traffic Stop:	12 for a total of	130 minutes
	<b>Total # of Activities:</b>	<b>96 for a total of</b>	<b>2945 minutes</b>
	<b>Total AA/SUT: DDACTS Zone 2 - MacArthur Blvd:</b>	<b>96 for a total of</b>	<b>2945 minutes ( 49 hours 5 minutes)</b>

**CHARTER TOWNSHIP OF SUPERIOR  
BOARD OF TRUSTEES**

**A RESOLUTION TO APPROVE AN AGREEMENT BETWEEN SUPERIOR  
TOWNSHIP AND THE WASHTENAW COUNTY ROAD COMMISSION FOR 2018  
ROAD IMPROVEMENTS**

**Resolution Number: 2018-17**

**Date: July 16, 2018**

**THIS AGREEMENT** made and entered into this 16<sup>th</sup> day of July, 2018 by and between the Board of Superior Charter Township (the “Township”) and the Board of Washtenaw County Road Commissioners (the “Road Commission”).

**WHEREAS**, both parties desire improvements of local roads located within Superior Township; and,

**WHEREAS**, included within their 2018 Annual Meeting report, the Road Commission has provided the Township with a list of proposed road improvement; and,

**WHEREAS**, the Township has historically contributed funds to the Road Commission for improvement of the local roads; and,

**NOW THEREFORE, BE IT AGREED** that the Township approves the Road Commission to complete following road improvement projects in 2018:

1. HARVEST LANE, RUSSETT ROAD TO MCINTOSH ROAD Work to include cold milling the existing pavement, the placement of 2.5” HMA resurfacing, structure adjustments, concrete curb and gutter removal and installation, and project restoration.

**Estimated project cost: \$ 81,500**

2. OVERBROOK COURT Work to include cold milling the existing pavement, the placement of 3” HMA resurfacing, and project restoration.

**Estimated project cost: \$ 38,000**

**NOW THEREFORE**, the Township approves the Superior Township Supervisor to sign the necessary agreements and the funds for the road improvements will be debited from G.L. 466-866.

**CHARTER TOWNSHIP OF SUPERIOR  
WASHTENAW COUNTY, MICHIGAN**

**RESOLUTION TO ACCEPT BID FROM  
HUTCH PAVING FOR REPAVING  
TIMBERWOOD COURT**

**Resolution Number: 2018-18**

**Date: July 16, 2018**

**WHEREAS**, Timberwood Court, a public road in Superior Township is in need of repair; and,

**WHEREAS**, Hutch Paving has extensive experience in supplying paving and associated work to the township for many years; and,

**WHEREAS**, the township requested a bid for repairs from the Washtenaw County Road Commission (WCRC) and the bid price was \$92,000.00; and,

**WHEREAS**, Hutch Paving will mill and replace the existing surface for \$38,500.00

**NOW THEREFORE, BE IT RESOLVED** that the Superior Township Board of Trustees hereby approves Hutch Paving to repair and replace Timberwood Court for an amount not to exceed \$38,500.00.

June 20, 2018

Kenneth Schwartz  
Superior Township  
3040 North Prospect Road  
Ypsilanti, MI 48198

RE: **TIMBERWOOD COURT  
ASPHALT REPAIR & OVERLAY APRON PACKAGE**

Dear Kenneth,

We have completed our evaluation for the proposed project.

This proposal presents the results of our observations and analysis, and our recommendations for the project construction methods as well as pertinent construction considerations.

All are in accordance with our meeting conducted 6/15/2018.

If you should have any questions or comments please contact me at your earliest convenience.

Otherwise I will follow up with you on a later date.

We look forward to working with you.

Respectfully Submitted,

**Mike A. Chunko**

Mike A. Chunko  
Sales Consultant  
Hutch Paving, Inc.  
The Professional Paving People™  
mchunko@hutchpaving.com  
Mobile 248.514.6922

**Client Information:**

Kenneth Schwartz  
Superior Township  
3040 North Prospect Road  
Ypsilanti, MI 48198

**Project Information:**

**Date:** 6/20/2018 9:03 AM

**Phone:** 734.482.6099

**Fax:** 734.482.3842

**Mobile:** 7344802060

**Email:** kenschwartz@superior-twp.org

**Bid No:** 71071

---

**ASPHALT REPAIR & OVERLAY WITH NEW CONCRETE CATCH BASIN APRON PACKAGE**

---

**ENGINEERING & SAFETY**

1. Provide all engineering and layout to perform this construction.
2. Maintain sufficient safety barricading during construction

**2.00" ASPHALT RESURFACING PACKAGE – 27,000 SF**

1. CLEAN EXISTING PAVEMENT
2. Wedge in & repair all low areas, holes, voids & deviations in the existing asphalt surface with #1100 20AA Leveling course asphalt ensuring asphalt is smooth before the installation of the 2.00" wearing course this will promote & yield improved consistency of new surface thickness.
3. Apply SS-1h emulsion (tack coat) asphalt binder to promote adhesion of bituminous concrete
4. Install 2.00" #1100 20AA MDOT SPEC Wearing course asphalt and compact.
5. Remove all debris associated with our work.

**OUR PRICE IS..... \$ 38,500.00**

**INCLUDES:** TWO YEAR LIMITED WRITTEN WARRANTY Excluding Reflective Cracking

**EXCLUDES:** Permits, Inspections, Undercutting of unsuitable sub base, restoration of Striping, restoration of landscaping, repair to hidden structures, such as but not limited to irrigation lines, electrical lines, or anything not marked by the miss dig system, repair to asphalt under milled surface.

By signing below, Superior Township \ agent agrees to the payment terms detailed and Terms and Conditions set forth below on all pages of this contract.

X

Print Name / Tile / Date

X

Superior Township \ Agent Authorized Agent Signature



## STANDARD TERMS & CONDITIONS

**WARRANTY COVERAGE:** Work quoted in our proposals is covered by our standard warranty against defects in materials and workmanship for a period of 12 months (unless specified otherwise) subject to the terms and conditions contained herein. Due to the volatility of the crude oil market and the potential for geopolitical issues, prices quoted are valid for 30 days from issue date of the proposal, unless specified otherwise.

**STANDARD TERMS:** This contract shall be subject to the following general conditions and standard terms of the contract printed below. Hutch Paving, Inc., will be referred to as contractor or HPI. The owner, architect, client or customer to whom this proposal/contract is addressed and authorized by will be referred to as "Customer".

A finance charge of 1-1/2% per month will be added to all past due accounts; an annum of 18%.

Payment is due in full upon completion or upon invoicing of completed work.

**NO ORAL AGREEMENTS:** It is expressly understood that all terms, agreements, and conditions relating to this contract are only those expressed in writing herein, and that there are no oral representations, undertakings, terms, agreements or conditions of any kind.

**CHANGES:** No changes or alterations in the specifications shall be allowed except in writing and at prices agreed upon at the time the changes are authorized.

**EXTRA WORK:** Any additional work requested beyond the specifications on the reverse side will be outlined in writing on a separate proposal form. Extra work performed on a time & material basis shall be signed for at the time the work is performed. The lack of a representative of the Customer does not relieve the Customer from payment obligation for the work billed.

**ESTIMATED OR APPROXIMATE QUANTITIES:** Quantities and areas in this proposal are approximate, arrived at for estimating purposes only. In addition, it is understood that payment is to be made on actual quantities of work completed and actual areas covered unless otherwise indicated.

**PROPERTY LINES:** The Customer shall establish and designate property lines, and shall be obligated to pay for work performed as ordered in the event the property lines established and designated by Customer trespass on other property. Also, the Customer shall be responsible for any damages caused hereby to the owner of any property encroached on by work specified in this proposal.

**DELAYS/TIME OF COMPLETION:** HPI shall complete this work within a reasonable time, but shall not be held responsible for delays beyond the control of the contractor.

**SUB GRADES:** No material shall be placed on a wet, unstable or frozen subgrade. A suitable subgrade is a condition precedent to the requirement of performance of this contract.

**MINIMUM GRADE:** HPI reserves the right to refuse to construct a pavement unless minimum grades of 1% are possible for surface drainage. If construction is performed with less than a minimum grade of 1%, it is understood that waterponding may occur and that there is no warranty attached to the work as to satisfactory surface drainage. Depressions over 3/4" can be filled.

**WATER DRAINAGE:** HPI will make water drain as best as possible. However, we make no guarantees against drainage of new or old pavement of any type when resurfacing and not replacing the project in its entirety.

**PERMITS:** Customers of the work shall obtain and pay for any and all permits, inspections or assessments if they are required, unless otherwise noted.

**ZONING REQUIREMENTS & REGULATIONS:** HPI assumes no responsibility for determining whether Customer has the legal right or authority to perform the work as specified. Notwithstanding that such work might be deemed to violate any ordinance, zoning regulation, or other law, the Customer shall, nevertheless, be obligated to pay for the work performed as ordered.

**REPRODUCTION OF CRACKS:** When resurfacing existing pavement of any type, HPI is not responsible for the reproduction of cracks ("reflective cracking") which may occur when resurfacing existing asphalt.

**STOCKPILING MATERIALS:** HPI shall be permitted to stockpile materials necessary to perform its work on the Customer's property or adjacent to the site of the work at no cost.

X

Client \ Agent Please Initial Here

**HIDDEN OBJECTS:** HPI assumes no responsibility for removing hidden objects encountered during the performance of their work, nor the cost associated with same.

**THICKNESS OF ASPHALT PAVEMENT:** All descriptions of pavement in this proposal refer to average thickness. Variations in subgrade and technical limitations may result in variations from the average. HPI warrants that sufficient material will be used on the project as to result in the average thickness specified.

**SOIL CONDITIONS:** HPI assumes no responsibility for any unusual soil conditions encountered that are not specifically referred to in this proposal. Also, HPI assumes no responsibility for the excavation, removal or disposal of any contaminated soils encountered during any excavation for the Customer. The Customer will pay any extra cost for such conditions incurred by HPI.

**TREE ROOTS:** Contractor shall not be responsible for any damage to trees occasioned by the removal of tree or tree roots in preparing the site.

**UNDERGROUND STRUCTURES:** It is the Customer's responsibility to advise contractor of the existence and location of all underground structures such as sewers, water lines, gas lines, etc., which might be encountered by HPI in the performance of its work. HPI shall be deemed to have notice of the existence of only those structures specifically referred to in this proposal and of the location thereof as indicated in this proposal. If a condition develops in the performance of HPI's work where the identity or location of the underground structures varies from those specified herein, any extra cost incurred thereby in moving, protecting or covering same, or otherwise, shall be borne by the Customer.

**COLD WEATHER CONDITIONS:** Effective October 1<sup>st</sup>, jobs are subject to winter conditions (50 degrees or below). Roller marks and asphalt marks may be visible due to cold weather temperatures.

**STREET PRINT®** The sample card replicates as closely as possible the Street Bond Surface System. Natural pigments are used in the colorants, and as a result some color variation may occur. It is recommended that these colors be applied in an inconspicuous area of asphalt to verify color choice.

**STAMPED CONCRETE:** Color samples shown represent the color of the finished product as closely as possible when sealed with two coats of hard bright sealer. Variations occur due to differences in cement aggregate, water/cement ratio, weather, finishing and application methods.

**NOTICE OF COMMENCEMENT:** Notice of Commencement is requested per Sec. 570.1108a (1)(9)(10)(11) of the Michigan Construction Lien Act 497 of 1980, on any signed contract.

**STANDARD TERMS OF CONTRACT:** Customer shall not withhold payment to HPI in the event of any dispute arising out of this contract. In the event of a dispute, Customer will deposit any unpaid balance due on this contract with a mutually agreed upon bank, which will act as an Escrow Agent until the dispute is resolved.

Any dispute arising out of this contract that cannot be resolved between the Customer and HPI shall be submitted to an arbitrator who shall be a registered engineer or architect selected by both parties. In the event the parties cannot agree upon such an arbitrator, the American Institute of Architects shall select the arbitrator and the arbitration proceedings shall be governed by their rules.

The decision of the arbitrator shall be binding upon the parties and enforceable in a Circuit Court for the State of Michigan. The arbitrator shall be empowered to direct the Escrow Agent to disburse the funds held in escrow to the proper party and to direct such other relief as he determines necessary.

The cost of the arbitration shall be borne equally by both parties.

In the event of an anticipatory breach of this contract by Customer, HPI shall be entitled to liquidated damages equal to 25% of the total contract amount.

The Customer shall pay HPI all costs, including actual attorney's fees, incurred by contractor in enforcing this contract, including collection of any payment due herein.

I have read all pages and agreed to these general conditions. The general conditions and prices and specifications associated with this contract are hereby accepted. Hutch Paving Inc. is authorized to perform this work.

**SUPERIOR CHARTER TOWNSHIP  
WASHTENAW COUNTY, MICHIGAN**

**A RESOLUTION TO APPROVE  
INFORMATION TECHNOLOGY PROVIDER**

**Resolution Number: 2018-19**

**Date: July 16, 2018**

**WHEREAS**, the Charter Township of Superior needs assistance with IT functions; and,

**WHEREAS**, the township's current IT provider has not met goals set forth between the administrative staff and the provider for many years; and,

**WHEREAS**, the township has requested updated computers, projectors and IT equipment for several years and has not received the promised equipment; and,

**WHEREAS**, township officials and staff have expressed great frustration with the current providers on a consistent, ongoing basis; and,

**WHEREAS**, speaking with township employee, all township employees have expressed frustration with the current providers and cannot get the simplest tasks resolved. For example, assessing has attempted to get the after hour's phone directory changed for three months to direct after hour's calls to the appropriate person. The current providers have not been able to implement such a simple change. Most computers are over ten years old with outdated operating systems, lack adequate security, and many other technical problems which are simple to fix but never get done; and,

**NOW THEREFORE, BE IT RESOLVED** that the Superior Township Board of Trustees accepts the bid from Nimble Systems of Ann Arbor to provide IT services to the township.



**Proposal for Superior Township  
IT Assessment  
July 9, 2018**

**Background.** We performed an assessment for you in February of 2014. At that time, we found your environment stable but under-managed, with two servers and 9 PCs at end of life, along with other issues. You had been receiving support for the past many years from a provider in Plymouth and chose to remain with that provider.

We recently met with you, and aside from one new server, you tell us that little else has changed, and you are now ready to make the switch to Nimble Systems. We both agree that the place to start is a fresh assessment.

This is a proposal for Nimble Systems to conduct an IT assessment that encompasses all five Township government locations (township hall, 2 fire department locations, 2 utility department locations). We can begin the assessment in late July/early August, upon your acceptance of this proposal and the Master Services Agreement.

You have indicated you wish ultimately to be on our Total-IT program. This assessment will identify any remediation required to be on a Total-IT plan and its cost, any recommended interim managed services and their cost, and the cost of Total-IT after remediation is complete.

**Assessment Deliverables.** Our assessment will produce the following:

- An inventory of Township hardware and software IT assets. Information will include when each computer or server was purchased, its warranty status, operating system, and associated recommendations.
- Produce an inventory of network equipment, including switches and routers, and associated recommendations.
- An enumeration of the top IT goals/needs of each department.
- Our assessment of the strengths and weaknesses of your current architecture in general and with respect to its ability to meet your stated goals.
- Our prioritized recommendations for addressing weaknesses and achieving goals.
- Recommended immediate managed services and costs.
- Total-IT costs post-remediation.

To help keep costs down, you have indicated a desire for an informal, verbal report with supporting documentation. Such documentation will include, at a minimum, a report detailing your inventory, a list of departmental goals, a list of strengths and weaknesses, and a list of recommendations and associated costs (including remediation, interim managed services, and Total-IT).

You indicated a desire for an IT plan. While this assessment won't produce a complete plan, it will provide a very sound basis for one, and will certainly identify any issues that require immediate remediation.

**Assessment Methodology and Schedule.** We'll use an updated version of the same methodology we used back in 2014, which is designed to surface any significant risks lurking in your IT environment and identify any areas you should focus on to reduce risk and improve efficacy. Some of the information we glean from staff interviews. We will also install our remote support agent on all Township computers, which will allow us to produce the inventory for reporting and analysis. Other facts come from taking a closer look at your servers.

Here are the questions the audit is designed to answer:

- What computers and software do you have in your inventory? How current are these assets? How well maintained?
- What network equipment do you have? Do you have a prudent level of protection against network intrusions?
- How well are you protected from risk of data loss?
- How well positioned are you to prevent significant outages of critical infrastructure, and to recover quickly from one if it occurs?
- At a general level, how well managed is your IT infrastructure?
- In general, how well is the infrastructure suited to meeting your goals?
- What immediate changes should be made, and what will that cost?
- What interim managed services make sense while remediation is in process?
- What will Total-IT cost once remediation is complete?

We can begin the assessment week of July 30. We will deliver results shortly after deploying the remote support agents and completing the staff interviews and site inspections.

**What you should plan to provide.** To complete the assessment, we will need:

- Up to one hour with Ken Schwartz and with each Department head to understand IT goals and unmet needs. This can be onsite or via phone interview. (If you prefer we interview this group together, we can do that.)
- A designated contact person at each site who can help us locate the IT assets on that site (computers, network equipment, etc.).
- Installed remote support agents. We've already provided a link for installing the remote support agent and your machines have begun to check in. The pricing herein assumes your users complete the installs.
- The Primary Administrator password for each of your servers.

- A list of the core applications that the Township uses for accounting, assessing/taxing, permitting, conducting elections, Fire Department incident reporting, utility services, and any other major Township government function/service. (We are aware of your BS&A and Firehouse use.)
- A sample recent Comcast bill (for each location if billed separately).

**Costs and payment terms.** We will conduct the assessment described herein for a flat, fixed fee of \$3,000, with half due upon proposal acceptance and half due upon delivery of our final report. We are happy to provide a money-back guarantee: if you are not satisfied with the assessment, we'll refund your down payment. Further, should you choose to become an on-going client, half the assessment fee will be credited toward future services.

**Accepted for Superior Township:**

By: \_\_\_\_\_ Date: \_\_\_\_\_  
signature

Name: \_\_\_\_\_ Title: \_\_\_\_\_  
please print



## **Nimble Systems Ad-Hoc Service Rates July 2018**

Hourly Rate: \$160

- Minimum charge 0.2 hours (\$32)
- Charged in increments of 0.1 hours (\$16)
- Satisfaction guaranteed: if we don't fix it, you don't pay
- Detailed statement of work performed included in every invoice

Service call (one per incident, even if multiple visits required): \$85  
(Many problems can be resolved remotely.)

Help Desk open at regular rates from 8:30-5:30 M-F.

Extended-hours support at \$230/hr, minimum charge 0.5 hours (\$115), charged in 15-minute increments. Available 7:30-8:30a and 5:30-7:30p Mon-Fri and 9:30-3:30 on weekends. (No extra charge for extended-hours server support if it is covered by a managed services plan.)

## MASTER SERVICE AGREEMENT

**THIS MASTER SERVICE AGREEMENT** (“**Agreement**”) is made this 19<sup>th</sup> day of December 2017 (“**Effective Date**”) by and between Shulman Clark Associates, LLC DBA Nimble Systems (“Nimble Systems”, “We” or “Us”), 3915 Research Park Drive Ste 13A, Ann Arbor, MI 48104 and Superior Charter Township (“You”).

1. **SCOPE OF AGREEMENT.** This Agreement serves as a master agreement and applies to your purchases from Nimble Systems of managed, project and ad-hoc services (collectively, “Services”), and of hardware and software. You hereby engage and retain Nimble Systems to render Services as set forth in various Statements of Work or Proposals or other mutually acceptable order documentation (collectively, “Orders”), all of which are incorporated herein by reference.

Ad-hoc, on-demand, hourly services and routine procurement will be provided under this Agreement. Provision of managed services or projects require the execution of one or more corresponding Orders, each of which must be executed by both of us and, upon such execution, are deemed incorporated in this Agreement for all purposes. You and we further agree that we may execute multiple Orders under this Agreement. In the event of any conflict between the terms of the Order and those of this Agreement, the terms of the Order will prevail over this Agreement.

2. **CONFIDENTIALITY AND NON-DISCLOSURE.** We both recognize that, from time to time, we may encounter information that the other Party considers confidential, and that we both desire to mutually and reciprocally protect each other’s confidential information. To that end, we jointly agree to the non-disclosure covenants as outlined in Appendix A.

3. **WARRANTY; DISCLAIMER.** We warrant our services to a reasonable standard or skill consistent with industry standards. We warrant that we will perform the Services substantially in accordance with the written specifications set forth under this Agreement, an Order or otherwise. We will use commercially-reasonable efforts to cure any services that do not conform to applicable specifications and that we rendered within the seven (7) business day period immediately preceding your notice to us specifying such non-conformance in reasonable detail. If we conclude that conformance is impracticable, then we will refund all fees you paid us, if any, directly allocable to such nonconforming Services.

Nimble Systems will pass through to you all third-party warranties applicable to hardware and software that we deliver to you. You acknowledge that no software is error-free and that all hardware is subject to breakdown or other failures. We disclaim any liability that results from unknown software errors or other anomalies and from hardware failures. If any of those problems occurs, we will use commercially reasonable good faith efforts to help you recover from them.

Nimble Systems disclaims all other warranties regarding its services. The remedies stated in this Section 3 are your only remedies for breach of warranty by Nimble Systems.

4. **INSURANCE.** Nimble Systems will maintain, at its own sole cost and expense, at least the following insurance covering its obligations under this Agreement: (a) Commercial General Liability including (i) bodily injury, (ii) property damage, (iii) contractual liability coverage, and (iv) personal injury, in an amount not less than One Million Dollars (\$1,000,000) per occurrence; (v) hired and non-owned vehicles in an amount of not less than One Million Dollars (\$1,000,000) for each accident; (c) Workers Compensation providing coverage of at least \$100,000 per accident or disease; and (d) Professional Liability Insurance covering errors and omissions and wrongful acts in the performance of the Services; such insurance will bear a combined single limit per occurrence of not less than One Million Dollars (\$1,000,000).

5. **OUR ACCESS AND MATERIALS REQUIRED TO DELIVER YOUR SERVICES.** You agree to provide us access to your facilities, equipment, personnel, documentation, access credentials and other resources we need to deliver you services under this Agreement. You also acknowledge that from time to time (a) Nimble Systems may identify additional items that you need to purchase, and (b) changes in your systems may be required for us to meet your requirements. You agree to work in good faith with us to provide such access and effectuate such purchases or

changes. You understand that if you fail to do so, we may be unable to perform our duties, and in that event, we may resign from that our work for you without liability.

**6. YOUR DATA AND SOFTWARE OWNERSHIP RESPONSIBILITY.** You shall have sole responsibility for the accuracy, quality, integrity, legality, reliability, appropriateness, and intellectual property ownership or right to use any data, information, software or material to which you give us access. If we are required to install any software provided by you as part of the Services, your act of providing such software to us will be deemed your affirmative acknowledgement to us that you have a valid license that permits us to install it. You are solely responsible for the installation of unlicensed software you provide unless we explicitly agree in a written Order that Nimble Systems agrees to assume responsibility. You will indemnify and hold us harmless against all damages and expenses we may incur (including reasonable attorney's fees and disbursements) related to your provision or use of software that infringes on its licensing terms.

**7. INTELLECTUAL PROPERTY.** We retain all intellectual property rights in any property we invent or compose during or incident to the performance of this Agreement, and any software, materials, or methods created prior to or after conclusion of any work. We grant you the limited right to use such intellectual property exclusively for your own benefit. You agree that your right to such property terminates if this agreement is terminated by either party for any reason. You agree not to disclose to or use such intellectual property for the benefit of third parties without our prior, written consent.

**8. LIMITATIONS OF LIABILITY.** Neither party shall be liable to the other party for incidental, consequential, special, indirect, punitive or exemplary damages, loss of good will or business profits, downtime, work stoppage, data loss, computer failure or malfunction and any other indirect damages, except for damages that result from the intentional infringement by Nimble Systems of a third party's intellectual property rights or other intentional misconduct by a Nimble Systems employee, officer, or agent. Under no circumstances shall the liability of Nimble Systems for damages of any kind exceed the greater of (a) the insurance coverage available to compensate for such damages, or (b) \$10,000.

Nimble Systems shall not be liable to you for any delay or failure of delivery or performance unless such delay or failure is the result of our sole negligence or willful misconduct.

You must give us written notice of your intent to claim damages within ninety (90) days following our provision of the service from which your claim results. You must make your claim in writing within one (1) year after the associated service was delivered. Failure to adhere to these provisions forever bars your claim

The express remedies set forth in this Agreement constitute your exclusive remedies, and our sole obligation and liability, for any claim (a) that a Service or deliverable provided hereunder does not conform to specifications or is otherwise defective, or (b) that the Services were performed improperly. Nimble Systems shall not be responsible for impairments to the Services caused by acts within control of you, your employees, agents, contractors, suppliers or licenses, the interoperability of Customer applications, or other cause reasonably within your control and not reasonably related to services provided under this Agreement.

**8. TERM AND TERMINATION.** This Agreement will begin on the Effective Date and will continue until it is terminated as provided in this Section. Nimble Systems may: (a) terminate a specific Order if you fail to pay any applicable fees due for that Order within ten (10) business days after receipt of written notice from Nimble Systems of non-payment; and/or (b) terminate this Agreement or an Order or (c) if you commit any other material breach of this Agreement and fail to cure such breach within thirty (30) days after receipt of written notice from us. If an Order for Services is terminated, you will promptly pay us for Services rendered and expenses incurred through the termination date.

You may terminate (a) an Order if Nimble Systems commits any material breach of this Agreement or terms and conditions in the Order and we fail to cure such a breach within thirty (30) days after you notify us in writing of the breach, (b) this Agreement, for any reason, with thirty (30) days written notice to us, provided that you promptly pay us for services rendered and products supplied by us prior to the effective date of termination.



9. **PAYMENT**. You will pay Nimble Systems all fees due upon receipt of an invoice specifying the amounts due ("**Fees**"). If payment is not received on or before any past due date, interest shall accrue and be payable at the rate of one and one-half percent (1.5%) per month from the date due until paid in full. You will pay all expenses, including attorneys' fees, incurred by Nimble Systems in enforcing its rights under this Agreement.
10. **SEVERABILITY**. If any provision of this Agreement is determined by a court to be illegal or unenforceable, such provision shall be revised and interpreted to the extent permitted by law or equity while preserving its original intent. The invalidity of any part of this Agreement shall not render invalid the remainder of this Agreement.
11. **AMENDMENT**. Parties may amend this agreement only in a written document signed by an authorized representative of each party.
12. **RELATIONSHIP**. The Parties are independent contractors; and this Agreement does not make the Parties principal and agent, partners, employer and employee; nor does it create a joint venture.
13. **LAW**. This Agreement shall be governed by and construed in accordance with the laws of the State of Michigan without reference to principles of conflicts of laws. The Parties irrevocably submit to the exclusive jurisdiction of the courts of the State of Michigan.
14. **WAIVER**. Failure by either Party to insist upon strict performance of any provision herein shall not be deemed a waiver by such Party of its rights or remedies, or a waiver by it of any subsequent default by the other Party.
15. **FORCE MAJEURE**. Except for your payment for service rendered, neither party shall be responsible for any failure to perform or delay caused where such failure or delay is due to circumstances reasonably beyond the party's control. This includes fire, flood, earthquake, volcanic eruption, explosion, lightning, wind, hail, tidal wave, landslide, act of God, acts of terrorism, cybercrimes, acts of war or any other event that is outside the control of the party whose performance is affected by that event.
16. **ASSIGNMENT**. Neither party may assign its rights or obligations under this Agreement without the other party's prior written consent which shall not be unreasonably withheld. Provided, however, that a party may assign this Agreement to a third party that acquires substantially all of the assets and business of that party, without seeking the consent of the other party.
17. **NOTICES**. All notices regarding this Agreement shall be given in writing and shall be delivered in person, by certified mail, return receipt requested, by overnight courier or by email, in each case with proof delivery. Notices shall be addressed to the recipient at the address below the recipient's signature line below or to another address designated by the recipient in writing. Notices shall be effective upon receipt.
18. **ENTIRE AGREEMENT**. This Agreement constitutes the entire agreement by and between the Parties regarding the subject matter contained herein, and supersedes all prior and contemporaneous undertakings and agreement of the Parties, whether written or oral, with respect to such subject matter.

Superior Charter Township

By: \_\_\_\_\_

3040 N Prospect Rd  
Superior Charter Twp, MI 48198

Date: \_\_\_\_\_

Nimble Systems

By: \_\_\_\_\_

3915 Research Park Dr, Suite 13A  
Ann Arbor, MI 48108

Date: \_\_\_\_\_

## **Appendix A. Confidentiality and Non-Disclosure**

Both parties acknowledge that they may have access to Confidential Information of the other party that is not in the public domain or which may be subject to specific legal protections, including but not limited to attorney-client privilege or attorney work-product privilege, the Health Insurance Portability and Accountability Act, the Payment Card Industry Data Security Standard, or other standards or laws. Confidential Information includes but is not limited to client/customer lists; business plans; operational standards and procedures; logos, domain names, and websites that are in use or planned; client/customer/vendor contracts; vendors and subcontractor names and contact information; business processes and procedures; financial information, business and product development plans; product designs, plans, and formulae; software source code and programmers' notes; financial records; all Client data, no matter how or where recorded; vendor account names, passwords, and account numbers; computer system user account names, passwords, and IP addresses; and any other information which by its nature is ordinarily treated as confidential in the information technology industry or is designated in writing as confidential.

The parties acknowledge that Nimble Systems may need to carry or have access to devices or information that permit access to Client's premises, equipment, data, or other assets. Such devices and information (collectively known as "Client Access Mechanisms") include but are not limited to keys, swipe cards, tokens, combinations, passcodes, usernames, and passwords. If such Client Access Mechanisms are lost or stolen, Nimble Systems agrees to report the loss to the client immediately. Nimble Systems will not disclose, duplicate, or permit the use of Client Access Mechanisms to or by anyone who is not duly authorized to have access.

Both parties shall, in perpetuity, keep in confidence and shall not use or disclose any Confidential Information without the written consent of the other party, unless such Confidential Information becomes publicly available through no fault of the party or except as may be necessary in the ordinary course of performing duties under this agreement, or as required by law after first providing the other party with advance notice and an opportunity to contest such a requirement.

Upon termination of this agreement for any reason, Nimble Systems agrees to turn over to client all Client Access Mechanisms in its possession, and Nimble System shall not use or disclose to any other party any Client Access Mechanisms.

The parties agree that the covenants set forth in this Appendix provide reasonable protection of the parties' interest in protecting its reputation and legal interests, and the parties will be entitled to injunctive relief to enforce these covenants.

**SUPERIOR CHARTER TOWNSHIP  
WASHTENAW COUNTY, MICHIGAN**

**A RESOLUTION AUTHORIZING THE SUPERIOR TOWNSHIP  
FIRE DEPARTMENT TO PARTICPATE IN A REGIONAL  
FEMA GRANT PROGRAM**

**Resolution Number: 2018-20**

**Date: July 16, 2018**

**WHEREAS**, the Superior Charter Township Fire Department been requested by FEMA to participate in a regional grant program for the purchase of “Self - Contained Breathing Apparatus (SCBA)”; and,

**WHEREAS**, Superior Township will be appointed the region-wide fiduciary and will be responsible for meeting the terms of the grant; and,

**WHEREAS**, Superior Township expects to receive up to sixteen (16) SCBA’s for the costs to the Township Fire Department of \$11,600.00 which equates to 10% of the total costs; and,

**WHEREAS**, FEMA requires the parties to the grant to sign a Memorandum of Understanding; and,

**NOW THEREFORE, BE IT RESOLVED** that the Superior Charter Township Board of Trustees authorizes the Fire Chief and/or the administrative staff to execute the memorandum of understanding.

## MEMO

**DATE:** July 10, 2018

**TO:** Superior Township Board of Trustees

**FROM:** Richard Mayernik, Building/Zoning Official

**RE:** Proposals for automatic door openers and cameras

At the request of the Officials, I have solicited proposals to install automatic door openers and cameras at the Township Hall.

**Automatic Door Operators**- Both public entrances into the Township Hall (General Offices and Board Room) consist of two sets of double doors with vestibules. These doors can be very difficult for people utilizing walkers or wheelchairs to navigate. The proposal would be to add automatic door operators to one interior and one exterior door at each location. Operator buttons would be located inside, outside and in the vestibule such that the doors could be opened automatically. The installation of these door operators will definitely improve the accessibility of our facility for those with disabilities.

We have received two proposals.....one from National Door Systems, LLC (\$7,349.00) and one from Record Automatic Doors, Inc. (\$9,200.00). Please note that electrical work is not included in either proposal. I would recommend the Board accept the proposal from National Door Systems, LLC. Additionally, I would recommend upgrading from the standard one year warranty to a two year warranty for an additional \$125.00 per operator (\$500.00 total). I would estimate the electrical work to be an additional \$2,500.00.

**Security Cameras**- I have received proposals to install a total of six (6) security cameras. Two cameras would be installed at the North parking lot and two cameras at the South lot for exterior coverage. One camera is proposed at the West wall of the Board Room (would view audience and entry doors) and a second interior camera would be located at the far North end of the General Office lobby (viewing the public service counters and entry doors).

We have received two proposals..... Allstar Alarm, LLC (\$4,365.00) and K & J Electric (\$6,355.10). I am expecting a third proposal from Knight Watch by 7/11/18. Of the two proposals in hand, I would recommend Allstar Alarm and would further recommend entering into the service agreement indicated on their proposal.

**From:** Rick Mayernik  
**Sent:** Thursday, July 12, 2018 9:43 AM  
**To:** Lynette Findley <[lynettefindley@superior-twp.org](mailto:lynettefindley@superior-twp.org)>  
**Subject:** FW: Proposal status

Lynette,

Please see the attached last proposal for the cameras that I was waiting for. I did notice that both the K & J quote and the Knight Watch quote indicate the exterior cameras to be vandal proof or protected. The Allstar Alarm quote does not indicate the same. If we are interested in that feature, I would recommend the Board approve an amount not to exceed \$6,500.00 for cameras. That would give us enough flexibility to have Allstar Alarm upgrade their bid.....or, switch and use K & J Electric if we wanted.

Rick M.

# Allstar Alarm LLC

---



June 21, 2018

Superior Township  
Rick Mayernik  
3040 N prospect Rd.  
Ypsilanti, MI 48198

Dear Rick,

Thank you for the opportunity to quote the install of your Camera System. This proposal includes the following:

## CAMERA SYSTEM

- One (1) HIK-Vision 8 Channel NVR
- Five (5) HIK-Vision 3MP 4MM High Definition Cameras
- One (1) HIK-Vision 3MP 2.8MM High Definition Cameras
- Wire & Hardware

Install Price: \$4,365.00 (includes tax)

Service Agreement: \$25.00 Trip charge; No-charge on parts or labor on all service calls \$36.00 per month.

50% due upon acceptance; remaining 50% due at completion.

## NOTES

1. Customer must have High Speed Internet to view Cameras remotely.
2. Customer to have their IT person available for programing Cameras to their server.

Please call me with any questions or let me know to proceed-I look forward to hearing from you soon.

Sincerely,

*Dave Csatari*

Dave Csatari

Accepted By \_\_\_\_\_ Date \_\_\_\_\_

**K & J Electric, Inc.**

7219 E. Highland Rd.  
 Howell, MI 48843  
 Phone: (517) 546-6245 Fax: (517) 548-7810  
 e-mail: donw@k-jelectric.com

**Proposal**

**Proposal Date:** 6/26/2018  
**Proposal #:** 1196

**Presented To:**

Charter Township of Superior  
 Richard Mayernik  
 3040 N. Prospect  
 Ypsilanti, MI 48198

Description	Project		
	Township Building Camera's		
	Estimated Hours/Qty.	Rate	Total
8 Channel NVR POE 2SATA HDMI 1TB Hard Drive	1	\$477.00	\$477.00
2MP Interior IR Dome IP Camera 4mm lens	2	\$172.00	\$344.00
2MP Exterior IR Vandal Dome IP Camera 2.8-12.0mm lens	4	\$335.00	\$1,340.00
Cat 6 cmp cable	1200	\$0.32	\$384.00
J-Hooks and bridle rings with beam clamps	40	\$2.90	\$116.00
3/4 EMT conduit, LB's, fittings	1	\$28.00	\$28.00
RJ-45 Connectors	12	\$0.80	\$9.60
Misc. materials, screws, sealers, etc.	1	\$26.50	\$26.50
Wall Mount Camera Bracket with Pendant Cap	4	\$50.00	\$200.00
Labor	1	\$3,430.00	\$3,430.00
<b>Total</b>			\$6,355.10

NOTE: Add \$45.00 to the quote for a 2TB Hard Drive  
 NOTE: This quote is based on using the conduit pipes in the meeting room to get out of the closet into the meeting room above the ceiling. There will be a extra charge if we have to install a conduit.

**Payment to be made as follows:**

\$6,355.10 Due upon completion of job. 15 days net.

All material is guaranteed to be as specified. All work to be completed in a workman-like manner according to standard practices. Any alteration or deviation from above specifications involving extra costs will be executed only upon written orders and will become an extra charge over and above the estimate. All agreements contingent upon strikes, accidents or delays beyond our control.

NOTE: This proposal will be withdrawn by said Company if not accepted within 30 days.

**Authorized Signature:** \_\_\_\_\_

**Date of Proposal:** 6/26/2018

**Acceptance of Proposal:** The above prices, specifications and conditions are satisfactory and are hereby accepted. You are authorized to do the work as specified. Payment will be made as outlined above. All accounts not paid within 30 days after billing date are subject to 1.5% Per Month (18% Per Year) Service Charge.

**Authorized Signature:** \_\_\_\_\_

**Date of Proposal:** \_\_\_\_\_





3005 Business One Drive  
Kalamazoo, MI 49048  
(269) 381-2100

1260 Rankin Dr. Suite G  
Troy, MI 48083  
(248) 850-8164

540 Leonard St. NW Suite G  
Grand Rapids, MI 49504  
(616) 235-2100

**Proposal**  
**EST09000**  
**07/11/18**

**Customer:** Superior Twp

**Project:** Superior Twp - CCTV

**Location:** 3040 N. Prospect  
Ypsilanti, MI 48198  
USA

**Prepared By:** Tom Kloc-tkloc@knightwatch.net

**Bill To:** 3040 N. Prospect  
Ypsilanti, MI 48198  
USA

Dear Rick Mayernik,

Knight Watch is pleased to provide this proposal for an IP based Video surveillance system manufactured by Hanwha Techwin America for the Superior Township Hall facility. Included in this proposal is a 4TB 8 channel video recording unit with camera licensing, (2) 2MP indoor dome cameras and (4) 5MP Outdoor vandal bullet cameras. All network cabling from Video appliance to the cameras is included in the proposal. Terminations, test and check as well as end user training is included as well as time to install the viewing client software on Township PC's if that is desired.

Qty	Description
700	CAT6 - Roll - Plenum - Blue - 1000' - Priced Per Foot
75	Cable Support - J Hook - 3/4" - with Clip
7	CAT6 - 1 Port Box - Surface Mount - White
14	CAT6 - Keystone Jack - White - EZ-Snap
1	CAT6 - Patch Panel - 1U - 24 Port - EZ-Snap
14	CAT6 - Patch Cable - Blue - 3'
1	1U - Brushed cable management tray
1	4K NVR, 4TB RAW, supports: 8 channels with 8 PoE/PoE+ ports, H.265/H.264/MJPEG, ARB (Automatic Recovery Backup), 2 fixed internal SATA HDDs (12TB max), WiseStream technology, max. resolution of 8MP recording/display and fisheye dewarping on web and CMS.
2	Wisenet III Network dome camera, 2MP, Full HD(1080p), Vari-Focal Lens 2.8x (3-8.5mm), H.264/MJPEG, 120dB WDR, SD/SDHC/SDXC, 12VDC/PoE
2	In-ceiling Flush Mount Accessory for HD-SDI, Wisenet III

Qty	Description
4	Wisenet X powered by Wisenet 5 network outdoor vandal bullet camera, 5MP @30fps, 7mm fixed lens (50.7°), triple codec H.265/H.264/MJPEG with WiseStream II technology, 120dB WDR, USB port for easy installation, advanced video analytics and sound classification and business analytics, high powered IR LEDs range of 98', true D/N, dual SD card, hallway view, HLC, defog detection, DIS, backbox included, 12VDC/PoE, IP67, IK10, Nema 4X
1	Rough-in Materials - Back Boxes, Fire-Stop, Etc.
1	Project Materials, Installation Hardware and Consumables
1	Freight
1	Install Remote Client Software
2	Labor Engineering
3	Labor Project Management
10	Programming
48	Labor Installation

- Proposal valid for 30 days.
- Labor included quoted at normal business hours.
- Payment is required within 30 days of invoice.
- 60% upon equipment order.
- Network connections for Viewing functionality provided by others
- Remote access is required to support the system

Sincerely,

Tom Kloc-tkloc@knightwatch.net

Subtotal	\$14,677.49
Tax	\$360.83
Total	\$15,038.32

Acceptance by you as the owner or authorized representative and subsequent approval by our authorized representative will be required to validate this agreement.

Customer Signature: \_\_\_\_\_

Date: \_\_\_\_/\_\_\_\_/\_\_\_\_



Optional  
mounting location

Superior Township Hall

Jack R. Smiley  
Nature Preserve

Cherry Hill Rd

Cherry Hill Rd

N Prospect Rd

N Prosp

Google



## NATIONAL DOOR SYSTEMS, LLC

---

715 Auburn Road ♦ Pontiac, Michigan 48343-0119  
(248) 332-0255 ♦ (248) 332-0256 FAX

6/19/2018

Proposal No. 06192018

Attention: Richard Mayernik  
Company: Charter Township of Superior

From: Adam Smith  
Project: ADA Operators, Push Plates and Bollard Posts

---

### Scope of Work – Furnish and Install

**NDS will furnish and install (4) ADA Operators, (4) Push Plate Transmitters, (2) Vestibule Push Plate Transmitters, (4) Receivers and (2) Bollard Posts.**

**\*Customer to provide electrical.**

**TOTAL PRICE: \$7,349.00**

#### Clarifications:

- Proposal based on walk through conducted on 06/18/2018
- We will only install swing operators to completed, finished openings
- Excludes Glass, Glazing and caulking
- Excludes Hollow metal doors and frame
- Assumes each opening and floor to be plumb and level
- Assumes header has support and backing to hang operator
- Assumes there is no medical testing required for this job-site
- Not responsible for structural or mechanical items interfering with the door opening prior to any demo work
- Site conditions are meet all OSHA standards and is free from snow, water and other foreign debris in work area.
- Excludes any Demolition
- Excludes any Access Control Hardware and Software or wiring, Alarm wiring or contacts
- Excludes any and all Keying
- Excludes all conduit, power or power wiring
- Excludes temporary security during installation
- Excludes Painting of door and surrounding area
- Excludes Barricades and Traffic Control
- Excludes any removal of concrete or concrete work
- Excludes any tile, carpet, masonry, drywall work or Painting
- Excluded Premium Time
- Excluded Structural Steel, Support Steel or Ancillary Steel
- Excludes Engineered Drawings (other than factory provided shop drawings)
- Excludes flashing, water management systems and/or breakmetal with any type of insulation material



Sincerely,  
*Adam Smith*  
Adam Smith  
asmith@[nds.nceusa.com](mailto:nds.nceusa.com)

The above prices, specifications and conditions are satisfactory and are hereby accepted. You are authorized to do the work as specified. Acceptance of this proposal also includes acceptance of all terms & conditions as noted below.

Date of Acceptance: \_\_\_\_\_

Signature: \_\_\_\_\_

Printed Name: \_\_\_\_\_

Company Name: \_\_\_\_\_

## PROPOSAL TERMS AND CONDITIONS

### Standard Terms and Conditions

- The above proposal is good for 30 days. After 30 days, we have the right to terminate completely, extend or amend the proposal accordingly.
- All work to be completed in a workmanlike manner according to standard practices. Any alteration or deviation from the above specifications involving extra costs will be executed only upon written orders, and will become an extra charge over and above the above. All agreements contingent upon strikes, accidents or delays beyond our control.

### Payments:

- Payments are to be upon completion of the work, if work is 30 days or less. If work is more than 30 days, monthly progress payments are to be made with final payment upon completion.
- Finance charge of 18% APR and legal costs to collect will be added to past due accounts

### Order Cancellation

- If order is cancelled during the approval process but prior to start of manufacturing or delivery of materials, or commencement of labor, there will be a 25% cancellation fee on the entire project amount
- If order is cancelled after materials have been manufactured and or delivered, then 100% of the material is to be paid plus 25% overhead fee and a 25% cancellation fee on the balance of the proposal will be due. Any costs associated with removal or re-shipping of materials, will be 100% due plus 25% overhead costs. In addition, if any labor has been performed, 100% of the labor costs will be due, plus 25% overhead.
- All title (ownership) of materials will stay with our company, until paid in full.

### General Conditions

- Any Permits, Licenses and Fees are not included, unless noted otherwise
- In the event that we incur any legal fees or costs in order to collect monies owed, those legal fees and costs shall be paid by the individual or business entity entering into this agreement. In addition, if we are sued for any reason relating to this agreement and we prevail in defending ourselves (meaning less than the full amount sought by the party instituting the lawsuit is awarded to that party or that we are not ordered to specifically



perform is such a lawsuit seeks a specific performance), then we are entitled to recover all legal fees and costs that we incur relating to such a lawsuit.

- Governing Law – Any and all disputes related to the above proposal, terms and conditions and any transaction between the parties, shall be brought in Oakland County, Michigan. The Parties hereby consent to the jurisdictions of said Court and waive any and all defenses of personal jurisdiction and venue.

**Termination**

- National Door Systems, LLC shall have the right at any time, upon written notice, to terminate this Subcontract in whole or in part; such termination shall be rightful as against executor of this contract whether undertaken because of executor default or for the convenience of NDS.

# record automatic doors, inc.

2185 Pontiac Road – Auburn Hills, MI 48326  
248-547-5933 Fax 248-547-2521 Cell: 810-499-2518  
E-mail: [lou.villalta@recorddoors.com](mailto:lou.villalta@recorddoors.com)

---

Date: Wednesday, June 20, 2018

Ph: 734-826-0819  
Attn: Rick Mayernik

**Project:** Superior Township. We are pleased to submit the following quotation for this project.

**Scope of work:** The scope of work, based on the project requirements and/or discussions with me is as follows: Furnish and install **record 8100 series** low energy operators with stainless steel push plates and bollard post per phone conversation with customer.

**Materials:**

- (4) **record 8100 series** low energy operators
- Surface Mounted
  - Microprocessor Controls
  - Activation per ANSI 156.19
  - 36" Wide Doors – Push side mounted
  - Finish: Clear Anodized

(8) Wireless Remote or Hard Wired Stainless steel push plates

(2) Bollard Posts

Furnished and installed; Net \$ 9,200.00  
Pricing is good for 30 days  
**Two** year warranty parts and labor included

**Schedule:** Upon formal acceptance of this proposal and receipt of approved shop drawings, if applicable, we will process pending projected installation schedule. Estimated lead time is **2-4 weeks**, materials and installation.

**Payment Terms:**

1. First time orders are subject to credit department approval and may require a 50% deposit, with the balance due upon substantial completion of installation, or net terms.
2. Visa, Master Card, or American Express will be accepted in lieu of credit application approval process.
3. Customers in our data base having not ordered equipment during the past 18 months will be subjected to credit approval.
4. Ordering of equipment, scheduling of work, and/or final tune of equipment, may not occur if it is determined by our credit department that customers account is more than 90 days in arrears. Past due balances may be subject to an interest rate of 1.75% per month.

**Qualifications:**

1. A notice of commencement is required prior to execution of this proposal.
2. Ordering of required materials and scheduling of the work cannot occur until this document is signed and returned to me either via fax: 248-547-2521, email [lou.villalta@recorddoors.com](mailto:lou.villalta@recorddoors.com), or

U.S. mail to: record automatic doors, inc., 2185 Pontiac Road, Auburn Hills, MI 48326. Or a hard copy purchase order is forwarded as indicated above.

3. Work shall be performed by factory-trained, union and AAADM certified employee during normal business hours. (Mon thru Friday 8:00 AM to 4:30 PM)
4. The project site will be kept free and clear of material and interruption by others to the best of the customer's ability. If a delay occurs, record automatic doors, inc. may invoice for the additional cost at applicable rates.
5. Any permits or bonds required by any governmental agency or to meet project requirements will be at the customer's expense and are not included in this proposal.
6. Please let us know if a certified payroll is required or if the job is prevailing wage.
7. Cancellations are subject to design, restocking and/or engineering cancellation charged.
8. The materials that have been installed will remain the property of record automatic door, inc. until payment has been made in full.

**By others:**

- a) Power supply to terminate at each control unit.
- b) Preparation to receive and support automatic door equipment.
- c) Conduits, back boxes and wires to complete installation.

If you have any questions or comments, please call me at your convenience.

Sincerely,

*Lou Villalta*

Lou Villalta  
Territory Sales Manager  
**record automatic doors, inc.**



This quotation, including the above information, is accepted

By: \_\_\_\_\_

Title: \_\_\_\_\_

Date: \_\_\_\_\_

P.O. # \_\_\_\_\_

**CONDITIONS:** Acceptance of this offer by the purchaser shall constitute an order and contract for the purchase of the items described herein. We shall not be liable for the non-performance of this contract, in whole or in part, if such non-performance is the result of any cause or causes beyond our reasonable control, including (but without limitation by reason of enumeration) the following: fires, strikes, differences with employees, casualties, delays in transportation, shortage of cars, government restrictions or other causes: nor shall these exceptions be limited or waived by any other terms of the contract, whether printed or written. In the event it shall become necessary for record automatic doors, inc. to enforce any of the provisions of this agreement, purchaser agrees to pay all cost and expenses associated with such enforcement including without limitation, the fee of a collection agency and attorney.



## 1 Description

The Bollard (P/N: 10BOLLARDBLK-black, 10BOLLARDBRZ-bronze, 10BOLLARDSLVS-silver) is used for mounting pushplates that activate automatic doors. It will accept BEA's 4 1/2" Square Pushplate, 4 3/4" Square Pushplate, 4 3/4" Panther Pushplate, Dual Vestibule Pushplate and 4 1/2" Round Pushplate. The post is made of durable carbon steel and the mounting bracket is made of stainless steel for strength. It can be mounted on either existing concrete or newly poured concrete.

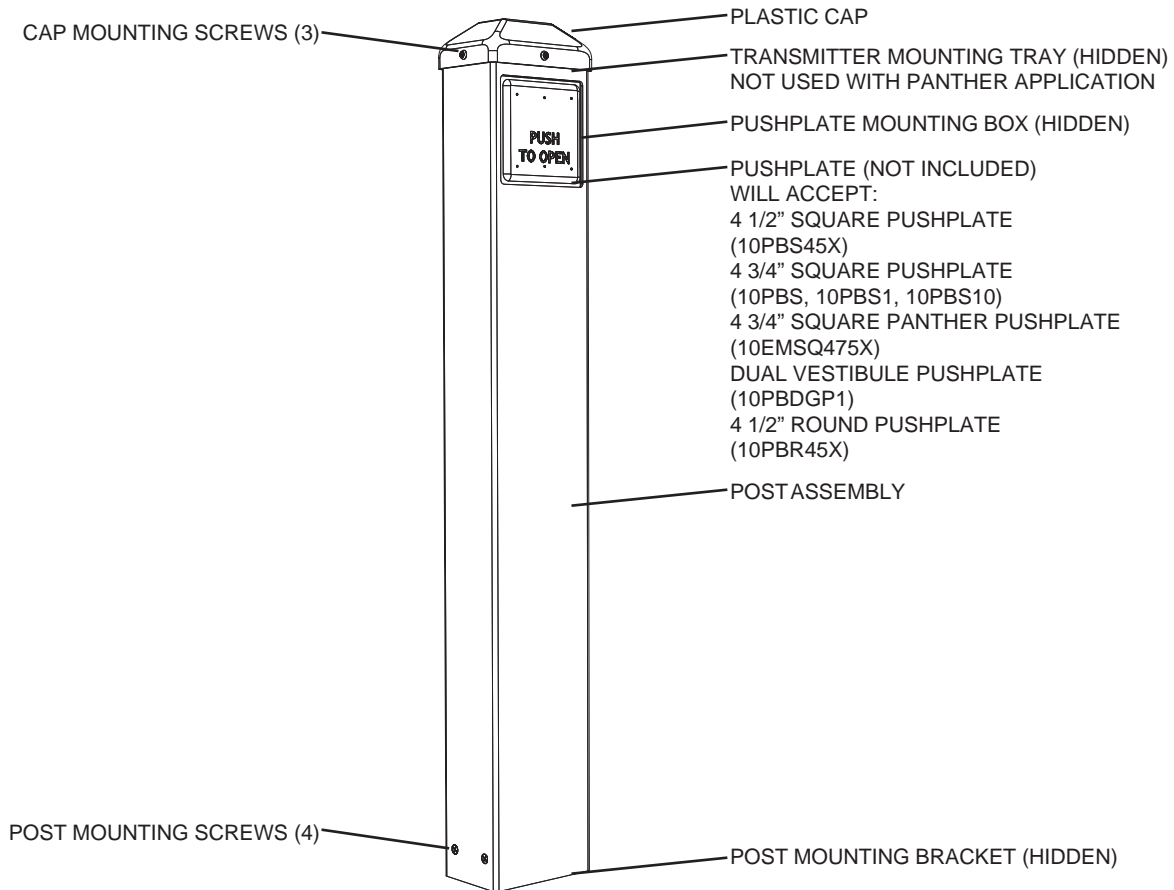

## 2 Specifications

DESCRIPTION	SPECIFICATION
Dimensions (with cap attached)	41 1/2"H x 6 1/4" W x 4 1/4"D
Material <ul style="list-style-type: none"> <li>• Post</li> <li>• Cap</li> <li>• Mounting Bracket</li> </ul>	Powder-Coated (Inside and Out) Carbon Steel UV-Resistant ABS Plastic Stainless Steel
Pushplate Options	4 1/2" Square Pushplate, 4 3/4" Square Pushplate, 4 3/4" Square Panther Pushplate, Dual Vestibule Pushplate and 4 1/2" Round Pushplate
Weight	35 lbs (16 kilos)
35 lbs (16 kilos)	Black, Bronze, Silver
Mounting Hardware	L-anchor, Expansion Anchor, Split Washer and Nut (Included)

### 3 Precautions



CAUTION

- Shut off all power going to header before attempting any wiring procedures.
- Maintain a clean & safe environment when working in public areas.
- Constantly be aware of pedestrian traffic around the door area.
- Always stop pedestrian traffic through the doorway when performing tests that may result in unexpected reactions by the door.
- Always check placement of all wiring before powering up to insure moving door parts will not catch any wires and cause damage to equipment.
- Ensure compliance with all applicable safety standards (i.e. ANSI A156.10) upon completion of installation.
- DO NOT attempt any internal repair of the sensor. All repairs and/or component replacements must be performed by BEA, Inc. Unauthorized disassembly or repair:
  1. May jeopardize personal safety and may expose one to the risk of electrical shock.
  2. May adversely affect the safe and reliable performance of the product will result in a voided product warranty.

### 4 Pre Installation Check

1. When preparing to wire multiple devices together for a "system" configuration, it is best to ensure the correct operation of each device independently before starting to help reduce troubleshooting time later in the event of a discrepancy.
2. Prior to installing any equipment, ensure correct line voltage and stability. When applying equipment on a new installation utilizing new electrical supply circuits, always ensure correct line voltage exists and is stable. Remember to shut the power back off after this is checked and before performing any wiring to the system.

### 5 Installation

#### 1 Hardwire Bracket - Optional

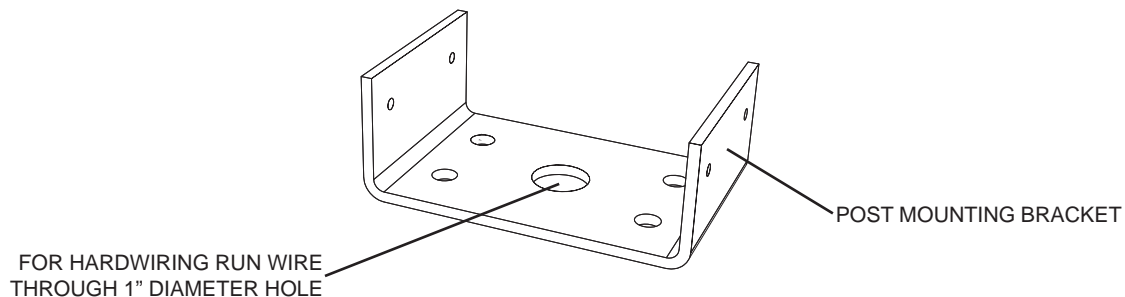

1. The Bollard is designed to house a pushplate used to activate a door by either a remote controlled transmitter or hardwired directly to the door control. If the door is hardwired, pass the wire through the 1 inch diameter hole in the mounting bracket.

#### 2 Attach Mounting Bracket Using Expansion Anchors - Existing Concrete

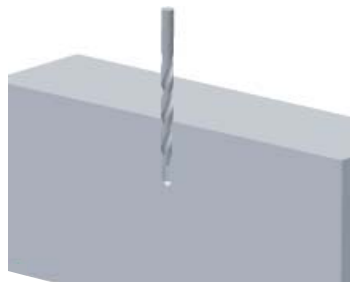

1. Mark and drill 3/8" diameter hole in four locations.

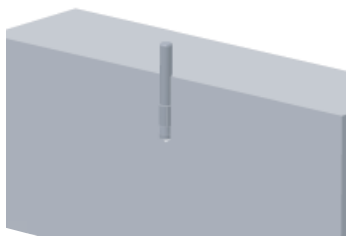

2. Hammer in and set anchor in four hole locations.

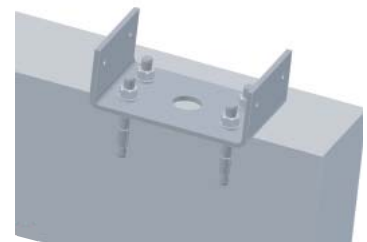

3. Install and tighten nuts to secure mounting bracket.

## 5 Installation (Continued)

### 3 Attach Mounting Bracket Using 'L' Shaped Anchors - New Concrete

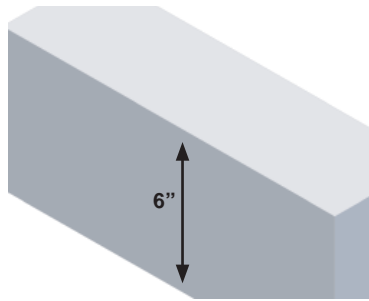

1. Pour concrete at least 6 inches deep.

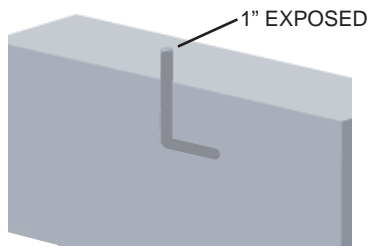

2. Insert anchors into curing concrete. Leave at least 1 inch exposed.

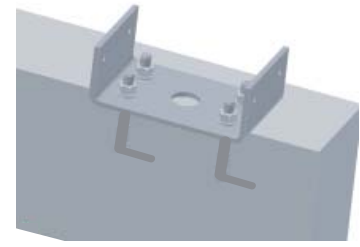

3. Once concrete has cured attach anchor and tighten nuts onto mounting bracket.

### 4 Attach Post to Mounting Bracket

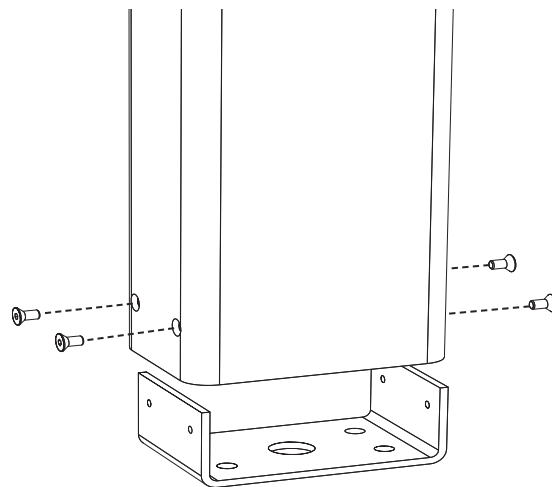

1. Align post to mounting bracket and attach post to mounting bracket with four post mounting screws.

### 5 Install Pushplate

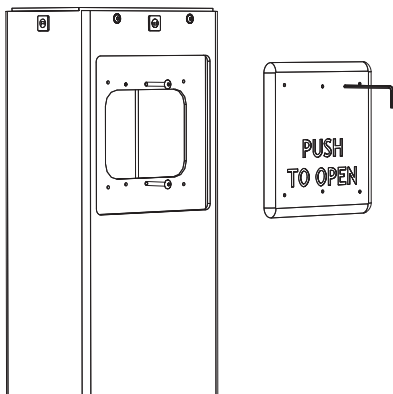

PUSHPLATE INSTALLATION

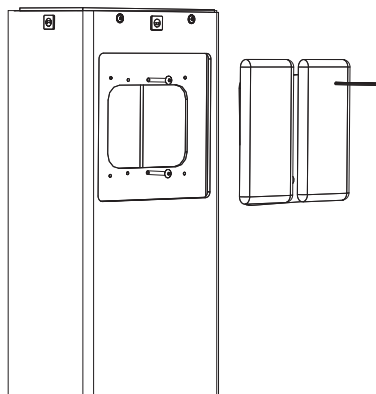

DUAL VESTIBULE INSTALLATION

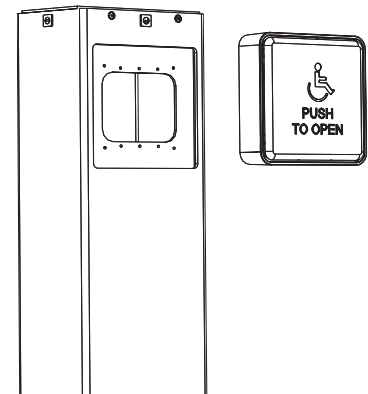

PANTHER PUSHPLATE INSTALLATION

1. Thread the pushplate screws into the mounting box leaving a majority of the screw exposed. Attach the pushplate to the mounting screws, then use the hex key provided to fully tighten the screws. Refer to the appropriate Pushplate User's Guide for detailed installation and setup instructions.

## 5 Installation (Continued)

### 6 Attach Transmitter

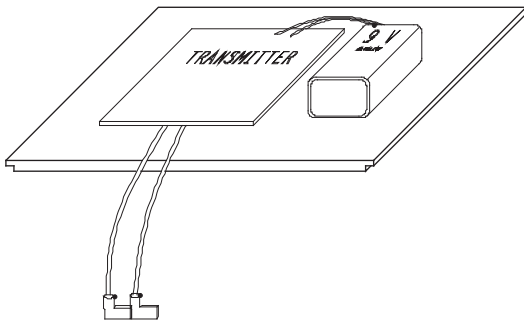

TRANSMITTER MOUNTING TRAY

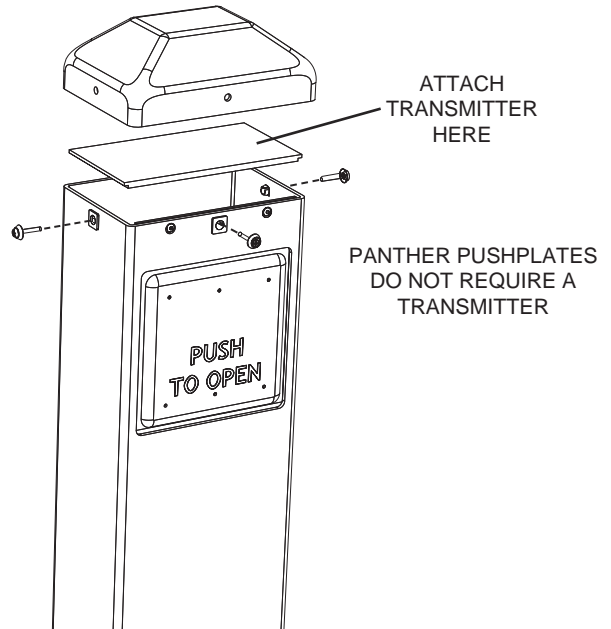

**CAUTION:** IF THE TRANSMITTER IS ALLOWED TO HANG DOWN INSIDE THE BOLLARD ERRATIC OPERATION MAY OCCUR.

1. If using the transmitter for this application, attach transmitter to mounting tray with velcro pad included in the package. Hardwired systems do not require this step.

2. Attach plastic cap to top of the post with three cap mounting screws. Tighten screws with hex key included in the pushplate package.

## 6 Company Contact



Do not leave problems unresolved. If a satisfactory solution cannot be achieved after troubleshooting a problem, please call BEA, Inc. If you must wait for the following workday to call BEA, leave the door inoperable until satisfactory repairs can be made. Never sacrifice the safe operation of the automatic door or gate for an incomplete solution.

The following numbers can be called 24 hours a day, 7 days a week. For more information visit [www.beasensors.com](http://www.beasensors.com).

West: 1-888-419-2564  
South-East: 1-800-407-4545  
US and Canada: 1-866-249-7937

Mid-West: 1-888-308-8843  
North-East: 1-866-836-1863  
Canada: 1-866-836-1863

# THE PANTHER EMS475 SERIES

LOW ENERGY DOOR ELECTRONICS



 Panther

EASY INSTALLATION  
NEMA-4 RATED  
SLIM PROFILE ONLY 1.5 in.

**Quality**  
**Intelligence**  
**Precision**

Easy mount wireless 4.75" square style push plate integrated with an RF433 code-encrypted security transmitter

- All-active surface made of durable stainless steel with a lifetime warranty
- Tamper-resistant recessed faceplate with beveled edges
- Aesthetically pleasing slim-line profile with no visible mounting holes
- The fully-assembled unit installs easily with a mounting plate or a standard two or four bolt gang box
- The housing can be directly installed to any flat surface such as a wall or mounting post (Bollard) using standard screws

WWW.BEASENSORS.COM

## EMS475 TECHNICAL SPECS

### Outer Dimensions

#### (Housing Assembly)

5.12 in. (W) x 5.12 in. (H)  
x 1.42 in. (D)

### Mounting Options

EasyMount kit  
Standard single gang box  
Standard double gang box  
Flat surface direct mounting  
without mounting kit or  
gang box

### Transmitter Operation

Wireless design  
433 Mhz digital frequency  
Rolling code encrypted  
for security  
FCC IC part 15 approved

### Power Source

12V Type A23 Battery (included)

### Finish

16 gauge, 304 2B  
stainless steel

## EMS475 DRAWINGS

### Front View

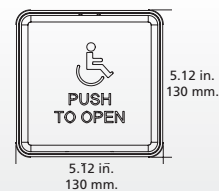

### Side View

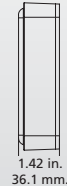

### 3D Perspective

Housing allows for  
direct mounting  
without mounting kit  
or gang box

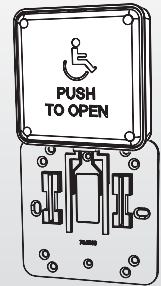

## EMS475 FAMILY OF PRODUCTS



10EMS475 - Text only



10EMS475L - Logo only



10EMS4751 - Text and Logo

## EMS475 APPLICATIONS



Slight pressure applied to anywhere on the all-active surface plate will open the low energy door.

## EMS475 DETAIL

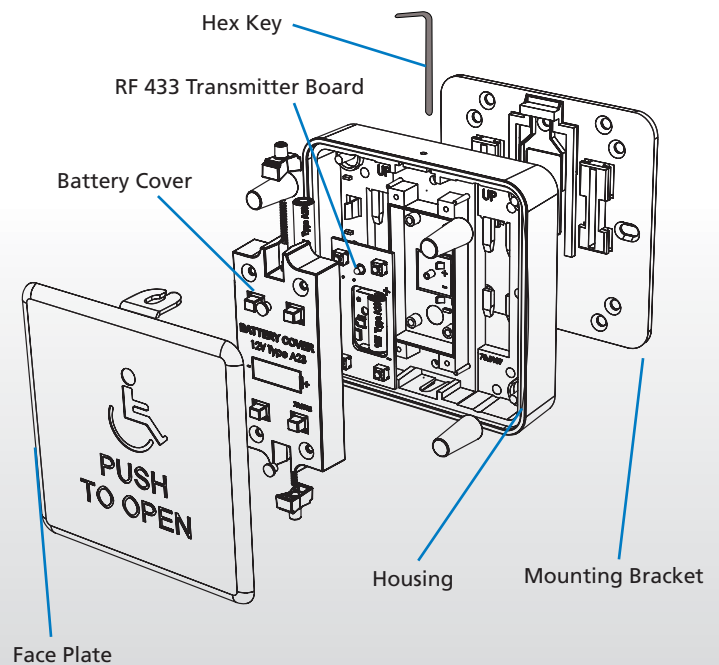

## EMS475 RELATED PRODUCTS



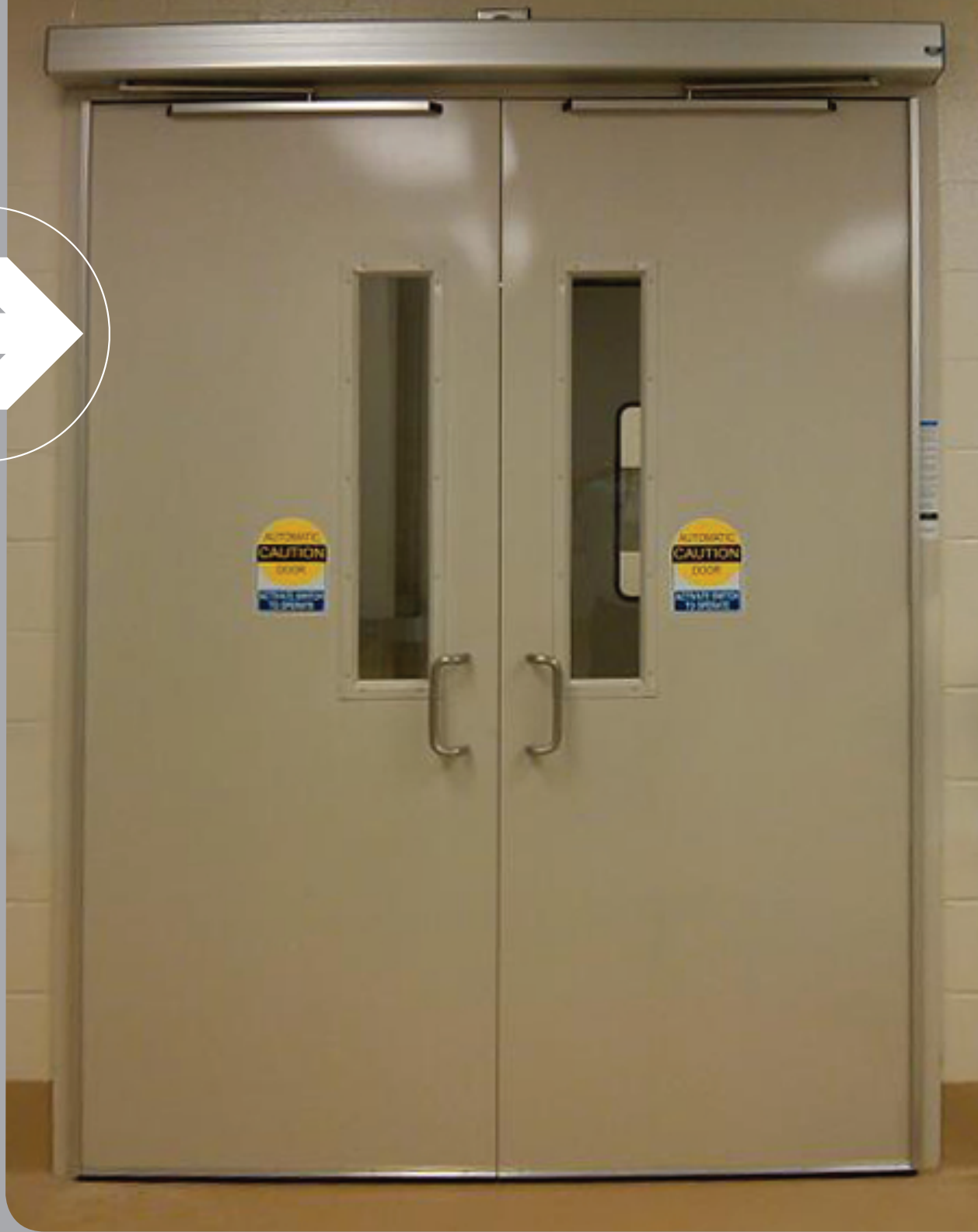
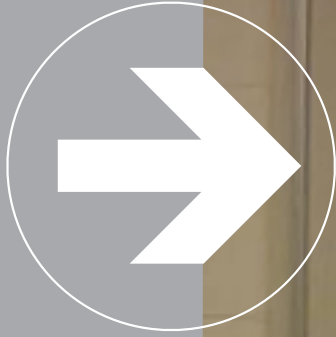

# 8100 Series Swing Door Heavy Duty Operator

Automatic door technology as you've never seen it before!



**record**

your global partner for entrance solutions

## 8100 Series

A proven planetary gear system in tandem with a perfected lever-system arm assures the smoothest, most quiet operation available without exception. Libraries, doctor offices, and healthcare facilities demand that their daily routines proceed without the common noisy distractions associated with many competitive products. Eliminate your worry of post install performance by specifying record-usa's 8100 series without hesitation.

Combined with World famed Swiss precision technology and a patented control system with 32 bit processor technology, the 8100 series is powerful and intelligent. The 8100 guarantees rapid and reliable door control performance, even when complex functions are desired.

When programming the 8100 series with record-usa's available hand held remote you will be greatly impressed with the quick and easy diagnostics and software updates that make field adjustment easy to configure and program. Using state of the art computer chip technology incorporating flash memory, the installing contractor can program multiple entranceways to open and close at the exact same speed with each and every opening.



record-usa's 8100 series swinging door operator makes everyone's decision making process simpler in that it truly can be selected for most any application. An ingenious design platform allows each unit to be used on virtually any door configuration including:

- Right hand or left hand doors
- Inswinging or outswinging doors
- Single, pairs or double egress doors
- Balanced doors
- Swing clear doors
- Interior doors
- Surface applied
- Center hung doors
- Butt hung doors
- Deep reveal applications
- Libraries, elderly care facilities, universities, hospitality, storefronts
- Front entrances in retail applications
- Meets ANSI A 156.19 requirements when adjusted properly
- Meets ANSI A 156.10 requirements when adjusted properly
- Exterior doors
- Fire rated openings
- Available clear or dark bronze anodized, custom painted, and clad
- ADA applications
- Electric strikes without additional relays or delays
- Up to 350 pounds per door leaf
- 30" doors through 96" door openings
- Push to start applications eliminate the need for additional activation accessories and complex field wiring
- Latch assist function assures closing in areas with heavy stack conditions commonly associated with doors in air conditioned and heated environments
- Specify 8200 Series when a squared header is desired.

## Brake Feature

An optional feature for the 8000 series Swing Door Operator systems is an internal clutch/ brake to maintain door position at the full-open and/ or full closed position(s). This electro-mechanical unit is integrated within the encoder assembly and will hold door position with 90 ft-lbs. torque. If forces are applied to the door which exceeds this force, the clutch feature of the unit will allow rotation without physical damage to the operator.

## Arm Options



The Standard Arm Assembly, 9-80-0010-CL, will work in out swing (push) applications up to a 12" reveal, and in swing (pull) applications up to a 6" reveal.

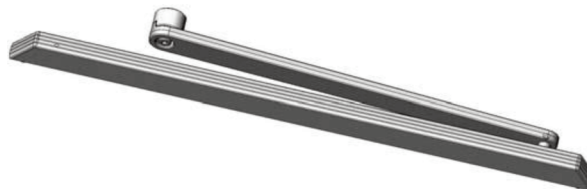

The Slide Track Arm Assembly, 9-80-0012-CL, will work in out swing (push) applications up to a 3" reveal, and in swing (pull) applications up to a 6" reveal.



The Offset Arm Adapter, 9-80-0011-CL, can be used with the above Slide Track Arm Assembly to provide a solution for special applications, such as center-pivoted doors with breakout capability, or double-egress installations using a continuous header.

Extended Reveal Applications will require an extension of the secondary (adjustable) arm portion of the Standard Arm Assembly. This is accomplished by combining two secondary arm assemblies. Reveals of up to 24" are possible.

# 8100 Series







RICK SNYDER  
GOVERNOR

State of Michigan  
Bureau of State Lottery  
101 E. Hillsdale • P.O. BOX 30023 • Lansing, Michigan 48909  
www.michigan.gov/cg • (517) 335-5780 • FAX (517) 267-2285



Aric Nesbitt  
COMMISSIONER

February 21, 2018

Organization ID: 139716

Eric Fretz  
Region 9 Veterans Community Action Team  
5860 Geddes Road  
Superior Twp, MI 48198



Dear Eric Fretz:

We have received documentation to qualify your organization as a Local Civic organization to conduct licensed gaming events as allowed by Act 382 of the Public Acts of 1972, as amended.

To complete the qualification process, please submit the following information:

1. A copy of the organization's current bylaws or constitution, including membership criteria, signed and dated by your principal officer.
2. A copy of the letter from the IRS stating the organization is exempt from federal income tax under IRS code 501(c) or copies of one bank statement per year for the previous five years, excluding the current year, from 2/21/2013 to 2/21/2017.
3. If incorporated, a complete filed copy of your Articles of Incorporation, including all amendments.
4. A provision in your bylaws, constitution, or Articles of Incorporation that states should the organization dissolve, all assets, and real and personal property will revert:
  - A. If exempt under 501(c)3, to another 501(c)3 organization.
  - B. If not exempt under 501(c)3, to the local government.
5. A copy of a resolution passed by the local government stating the organization is a recognized nonprofit organization in the community; form enclosed.
6. A revenue and expense statement for the previous 12 month period to prove all assets are used for charitable purposes, i.e. 990's, treasurer's report, audit. Do not send check registers or cancelled checks. Explain the purpose of each expenditure made to an individual. Once the organization has conducted licensed gaming events, the Bureau may require the organization to provide additional proof that all assets are being used for charitable purposes.
7. A provision in the bylaws, constitution, or Articles of Incorporation indicating the organization will remain nonprofit forever.
8. A written statement defining your membership criteria, if any. The Charitable Gaming rules require the licensed gaming event chairperson(s) be a bona fide member for 6 months. If you do not have general membership criteria, your chairperson(s) must be members of your board of directors.
9. Proof of a current bank account in the name of the organization.

Please enclose a copy of this letter with the requested information and mail, fax to 517/267-2285, or email to [CG-Additional-Info@michigan.gov](mailto:CG-Additional-Info@michigan.gov). Be sure to include your organization ID number 139716 on all correspondence submitted to our office.

We look forward to working with you in the future. If you have any questions or need further assistance, please contact us at 517/335-5780.

Sincerely,

Charitable Gaming Division



Charitable Gaming Division  
Box 30023, Lansing, MI 48909  
OVERNIGHT DELIVERY:  
101 E. Hilldale, Lansing MI 48933  
(517) 335-5780  
www.michigan.gov/cg

**LOCAL GOVERNING BODY RESOLUTION FOR CHARITABLE GAMING LICENSES**  
(Required by MCL 432.103(K)(ii))

At a \_\_\_\_\_ meeting of the \_\_\_\_\_  
REGULAR OR SPECIAL TOWNSHIP, CITY, OR VILLAGE COUNCIL/BOARD

called to order by \_\_\_\_\_ on \_\_\_\_\_  
DATE

at \_\_\_\_\_ a.m./p.m. the following resolution was offered:  
TIME

Moved by \_\_\_\_\_ and supported by \_\_\_\_\_

that the request from \_\_\_\_\_ of \_\_\_\_\_  
NAME OF ORGANIZATION CITY

county of \_\_\_\_\_, asking that they be recognized as a  
COUNTY NAME

nonprofit organization operating in the community for the purpose of obtaining charitable

gaming licenses, be considered for \_\_\_\_\_  
APPROVAL/DISAPPROVAL

**APPROVAL**

**DISAPPROVAL**

Yeas: \_\_\_\_\_

Yeas: \_\_\_\_\_

Nays: \_\_\_\_\_

Nays: \_\_\_\_\_

Absent: \_\_\_\_\_

Absent: \_\_\_\_\_

I hereby certify that the foregoing is a true and complete copy of a resolution offered and

adopted by the \_\_\_\_\_ at a \_\_\_\_\_  
TOWNSHIP, CITY, OR VILLAGE COUNCIL/BOARD REGULAR OR SPECIAL

meeting held on \_\_\_\_\_  
DATE

SIGNED: \_\_\_\_\_  
TOWNSHIP, CITY, OR VILLAGE CLERK

PRINTED NAME AND TITLE

ADDRESS

COMPLETION: Required.  
PENALTY: Possible denial of application.  
BSL-CG-1153(R6/09)

**From:** McGow, Patrick F. [<mailto:mcgow@millercanfield.com>]  
**Sent:** Friday, June 29, 2018 6:17 PM  
**To:** Ken Schwartz  
**Cc:** McGow, Patrick F.  
**Subject:** Miller Canfield Consent Request

Mr. Schwartz-

As a follow up to our phone conversation earlier this week, our firm has been asked to represent the Ann-Hua Chinese School (the "School") in connection with the property acquisition, zoning and other real estate matters relating to their potential purchase of property located at 5800 Cherry Hill Road to be used as a school. My colleagues in our Troy office, Alex Clark and Xuanzhong Van Oosterhout, have been asked to assist the School with matters relating to the project, including any necessary zoning, Master Plan or site plan approvals or amendments.

As you know, we have represented Superior Township in the past on various bond and finance matters and although we do not have any current projects, hope to do so again in the future. As you are aware, Rule 1.7 of the Michigan Rules of Professional Conduct establishes the general rule that a lawyer or firm may not represent a client if the representation of that client will be directly adverse to another client unless (i) we reasonably believe that the representation will not adversely affect the relationship with the other client; and (ii) consent from both clients is obtained. We do not believe that our representation of the School in this matter will affect our ability to represent the Township on the other matters that we may be asked to assist with. The project is not related in any way to the other legal work our firm performs for the Township. The work for the School will not be performed by attorneys who work with the Township, and similarly, the attorneys at our firm who work for the Township would not be working with or for the School. Furthermore, if this becomes adversarial, the consent would not extend to our representation of the School in litigation proceedings and we would not represent the School in any litigation against the Township.

I understand that you anticipate taking this request to the Township Board meeting on July 16<sup>th</sup>. If approved, I would appreciate it if you could send a written response to this e-mail indicating whether the Township would consent to our representation of the School in this matter.

If you have any questions or want to discuss this further, please let me know. I will be on vacation from June 30<sup>th</sup> through July 6<sup>th</sup>, returning to the office on July 9<sup>th</sup>. Thank you.

---

**Patrick F. McGow** | Attorney and Counselor at Law  
**Miller Canfield**  
150 West Jefferson, Suite 2500  
Detroit, Michigan 48226  
T 313.496.7684 | F 313.496.8451  
[mcgow@millercanfield.com](mailto:mcgow@millercanfield.com) | [View Profile + VCard](#)

---

This electronic message and all of its contents and attachments contain information from the law firm of Miller, Canfield, Paddock and Stone, P.L.C. which may be privileged, confidential or otherwise protected from disclosure. The information is intended to be for the addressee only. If you are not the addressee, then any disclosure, copying, distribution or use of this message, or its contents or any of its attachments, is prohibited. If you have received this electronic message in error, please notify us immediately and destroy the original message and all copies.



June 8, 2018

**To:** *Huron River Watershed Council Member Communities*  
**From:** *Laura Rubin, Executive Director*

I'm writing to thank you for your support of the Huron River Watershed Council (HRWC), to provide you with a brief update on the accomplishments of the past year, and to submit an invoice for services in the coming year.

First, thank you for your continued support of the HRWC's work. I know that your budgets are tight and that every dollar counts. Your membership counts; it goes directly to protect clean water, recreational opportunities, and a high quality of life. It allows us to provide services and conduct research not otherwise provided through grant funding and provide matching funds for grants. And, very importantly, your membership, compounded by the many government entities in our watershed who are also members, amplifies your voices and allows HRWC to weigh in on issues of importance if and when they arise. The HRWC currently matches each dollar of government member dues with just under **twenty three dollars** from other sources.

This past year the HRWC continued to expand its programs and services and to receive accolades for that work. For a brief summary of our successes in 2017, please go to <https://www.hrwc.org/wp-content/uploads/HRWC-Annual-Report-2016-2017.pdf>. That is the link to our annual report. You can also go to [www.hrwc.org](http://www.hrwc.org) and click on About Us, Annual Reports and Financial Statements and then the year.

The formula for calculating dues for membership in the Watershed Council remains the same:

- The formula for cities, villages, and townships is \$0.10 per capita;
- The formula for counties is \$0.05 per capita plus \$1.50 per square mile in the watershed.

Dues have been calculated based on the 2016 estimated census data per SEMCOG; the minimum value for annual dues remains at \$400; dues for larger communities have no cap; and communities are only billed for the percentage of their population estimated to live within the watershed.

We understand the financial pressures on local resources and are happy to come to your board meeting to talk about the benefits of membership and answer questions. Please feel free to call me or your HRWC Board representative.

If you have any questions about the attached bill, please contact our Operations Director, Jennifer Kangas, at (734)769-5123 x 604 or [jkangas@hrwc.org](mailto:jkangas@hrwc.org).

Again, thank for your membership in HRWC. We look forward to another year of working collectively to protect and restore the Huron.

Yours truly,

A handwritten signature in blue ink that reads "Laura".

Laura Rubin  
Executive Director  
[lrubin@hrwc.org](mailto:lrubin@hrwc.org)



## **HURON RIVER WATERSHED COUNCIL**

### **Services Provided to Member Governments**

The Huron River Watershed Council is a public, nonprofit coalition of local governments, businesses, and citizens established to protect the Huron River and its tributary streams, lakes, wetlands, and groundwater. Membership is voluntary for municipalities located wholly or partially within the Huron River Watershed. Annual membership dues for townships, cities, and villages are assessed at a rate of \$0.10 per capita (based on 2010 census figures). Annual dues for counties are assessed at a rate of \$0.05 per capita (watershed population) plus \$1.50 per square mile of watershed area. Each community is able to appoint one representative and an alternate to the Council for each 20,000 in population. For counties, representation is based upon the population of eligible communities not otherwise represented. The following are programs and services of the Council that communities receive for their membership.

#### ***I. Water Quality Monitoring and Education***

##### **A. Promote and Coordinate Studies Regarding Water Resources**

1. HRWC staff, board members, and volunteers serve on local river/watershed related committees and work with lake associations, municipal agencies and departments as requested;
2. The Council performs fieldwork to generate water quality information (stream and river quality, too), and utilizes that and other existing water quality and quantity information to develop watershed management plans for priority areas of the Huron River Basin;
3. The Adopt-A-Stream program generates creek reports for the creeks and streams in the monitoring program.

##### **B. Prepare periodic reports concerning emerging issues within the Huron River Watershed**

##### **C. Provide specific information to the public regarding the Huron River, its lakes, streams, flood plains, wetlands and groundwater, and research conducted by the Council**

##### **D. Distribute a quarterly newsletter on water resource issues**

The newsletter informs members of Council activities and emerging issues regarding water quality and the Huron River. Copies are provided for each member of the community's governing board and planning commission. Additional copies are provided for distribution to the public visiting the municipal offices and through area public libraries. Additional action bulletins/e-mails are distributed when the need arises to detail important initiatives affecting the river.

##### **E. Conduct presentations, workshops, and hands-on educational programs on the Huron River and its ecosystem**

1. We train teachers in the use of environmental education materials on rivers, wetlands, and groundwater, and develop new curricula to augment existing curricula;
2. The Council has developed the State's premiere Adopt-A-Stream program through which citizen volunteers receive hands-on training to

- learn stream ecology, assess the health of area creeks and take action locally to protect these sensitive systems;
3. Staff is available to do video and slide presentations.

**II. *Technical Assistance and Policy Development***

**A. Provide technical analysis of data and reports regarding water resources**

**B. Provide technical assistance in the development of water resource protection policy and ordinances**

1. We assist local planners in stormwater management planning, and in developing ordinances/policies for protecting wetlands, flood plains, riparian zones and groundwater resources;
2. The Council also provides statewide leadership in issues related to watershed protection.

**C. Permit and development proposal review/assessment of potential impacts to surface and groundwater resources**

1. HRWC staff and technical advisors review permit applications under Michigan's Goemaere-Anderson Wetland Protection Act, Inland Lakes and Streams Act, Flood Plain Regulatory Authority, and National Pollution Discharge Elimination Program and other programs administered by State and Federal Agencies;
2. We also provide technical assistance on proposed development plans and environmental management plans and practices.

**III. *Regional, State and Federal Representation***

**A. Provide member governments with a forum for the resolution of inter-governmental disputes or inter-jurisdictional problems arising from the management of shared water resources.**

**B. Provide regional representation by serving on committees**

**C. Comment upon State and Federal legislation, polity or planning initiatives that affect local governments and water resources.**

In addition, the Council will perform more in-depth work on each of the above services on a fee-for-service based system. Some additional services not mentioned above include:

- Informational and educational "tip" cards providing steps/ideas on how to conserve water in the home, care for a septic system, use watershed-friendly lawn care products, properly dispose of hazardous waste and more.
- Land Use planning tools
- Stormwater permits
- Natural feature mapping/GIS
- Facilitation of inter-governmental planning



Huron  
River  
Watershed  
Council

1100 N. Main St. Suite 210  
Ann Arbor, MI 48104

# Invoice

DATE            INVOICE #  
6/11/2018       2170

BILL TO

CLERK'S OFFICE  
SUPERIOR TOWNSHIP  
3040 N. PROSPECT RD.  
YPSILANTI, MI 48198

(734) 769-5123 x 604  
jkangas@hrwc.org  
www.hrwc.org

TERMS

DESCRIPTION	AMOUNT	
2018 HRWC Membership Dues	746.93	
	Total	\$746.93



# Washtenaw County Clean Up Day

**Saturday, October 20, 2018**  
**9AM - 2PM**

Eastern Michigan University  
Parking lot across from Rynearson Stadium  
799 N. Hewitt, Ypsilanti

## What to bring

- Traditional recyclable materials  
(glass, cardboard, plastic, paper, scrap metal)
- Appliances  
(refrigerator, dryer, a/c unit, etc.)
- Household hazardous materials  
(paint, pesticides, cleaning supplies, oil, etc.)
- Tires
- Electronics  
(TV, computer, etc.)
- Bulky household items  
(mattress, furniture, etc.)
- Construction and demolition waste  
(drywall, concrete, wood, bricks, etc.)

***No household garbage will be accepted!***



## Suggested donations

Please consider a **minimum donation of \$10.00** to help support this effort.

Bring 4 tires for free. We request a donation of \$5 for each additional tire.

Bring 1 TV, computer or appliance for free. We request a donation of \$10 for each additional item.

***This event is for Washtenaw County residents. Sorry, but we can't accept materials from businesses or out-of-county residents.***

Call **734-222-3810** or visit **[www.washtenaw.org/cleanup](http://www.washtenaw.org/cleanup)** for more info!



### **Sponsored by:**

Washtenaw County Water Resources Commissioner's Office  
Board of Public Works • Eastern Michigan University  
City of Ann Arbor • Superior Township • Saint Joseph Mercy Health System



# SUPERIOR TOWNSHIP BILLS FOR PAYMENT

Date: July 16, 2018

GENERAL FUND	NONE TO SUBMIT
FIRE	NONE TO SUBMIT
LAW	NONE TO SUBMIT
PARK	NONE TO SUBMIT
BUILDING	NONE TO SUBMIT
UTILITY	NONE TO SUBMIT



# SUPERIOR TOWNSHIP

## Record of Disbursements

Date: July 16, 2018

\*Contains all checks written since last report for the following funds:

General Bank - includes all checks written from the following funds:

101 - General Fund

204 - Legal Defense Fund

219 - Streetlight Fund

220 - Side Street Maintenance Fund

249 - Building Fund

266 - Law Fund

508 - Park Fund

701 - Trust & Agency Fund

206 - Fire Fund

592 - Utility Dept.

**Total amount for all disbursements - \$735,729.36**

Note: Some of these checks were presented to the board for approval. All others are either pre-approved or under \$3,000.00 for Government Funds and \$5,000 for Utility Dept.

Check Date	Bank	Check	Vendor Name	Description	Amount
Bank GENL GENERAL BANK					
Check Type: Paper Check					
06/19/2018	GENL	40592	ALL SEASONS LANDSCAPING CO. INC.	WEED WHIP REPAIR	124.01
06/19/2018	GENL	40593	ANN ARBOR AREA TRANSPORTATION AUTH.	JUNE 2018	7,197.69
06/19/2018	GENL	40594	BLUE CROSS/BLUE SHIELD-M	MEDICAL INSURANCE - 2018	7,632.42
06/19/2018	GENL	40595	BRENDA MCKINNEY	CELL PHONE STIPEND - 2018	50.57
06/19/2018	GENL	40596	CINTAS CORPORATION - 300	RUG SERVICE WEEK OF 6/14/18	131.27
06/19/2018	GENL	40597	CONSUMERS LIFE INSURANCE CO	LIFE INSURANCE 2018	164.58
06/19/2018	GENL	40598	CORBET GRIFFITH	DUMP TICKET REIMBURSEMENT	18.75
06/19/2018	GENL	40599	DELTA DENTAL	DENTAL INSURANCE 2018	677.17
06/19/2018	GENL	40600	DONALD PENNINGTON LAND USE PLANNERS	CONSULTING SERVICES	5,039.25
06/19/2018	GENL	40601	DTE ENERGY	LED LIGHTING COVERSON MACARTHUR (BETWEE	6,273.28
06/19/2018	GENL	40602	FEDEX	OVERNIGHT TO COMERICA BANK	28.88
06/19/2018	GENL	40603	JALEEN WILSON	TRASH PICK-UP MACARTHUR	195.00
06/19/2018	GENL	40604	JUAN BRADFORD	NAME BADGES	45.02
06/19/2018	GENL	40605	KENNETH SCHWARTZ	DUMP TICKET REIMBURSEMENT	22.00
06/19/2018	GENL	40606	LEE MATTHEWS	DUMP TICKET REIMBURSEMENT	34.50
06/19/2018	GENL	40607	PARHELION TECHNOLOGIES	ANTI-SPAM/EMAIL/SERVER - JAN 2017	6,796.25
06/19/2018	GENL	40608	VOID		0.00 V
			Void Reason: Created From Check Run Process		
06/19/2018	GENL	40609	VOID		0.00 V
			Void Reason: Created From Check Run Process		
06/19/2018	GENL	40610	VOID		0.00 V
			Void Reason: Created From Check Run Process		
06/19/2018	GENL	40611	VOID		0.00 V
			Void Reason: Created From Check Run Process		
06/19/2018	GENL	40612	VOID		0.00 V
			Void Reason: Created From Check Run Process		
06/19/2018	GENL	40613	VOID		0.00 V
			Void Reason: Created From Check Run Process		
06/19/2018	GENL	40614	VOID		0.00 V
			Void Reason: Created From Check Run Process		
06/19/2018	GENL	40615	PAULA CALOPISIS	CELL PHONE STIPEND - 2018	50.57
06/19/2018	GENL	40616	PRINTING SYSTEMS, INC.	AV POST CARDS	530.30
06/19/2018	GENL	40617	RICHARD AQUILINE	DUMP TICKET REIMBURSEMENT	50.00
06/19/2018	GENL	40618	RICHARD MAYERNIK	CELL PHONE STIPEND - 2018	50.57
06/19/2018	GENL	40619	ROBERT BUTLER	2018 CONTRACT	1,519.55
06/19/2018	GENL	40620	S.E.M.M.I.A.	MEMEBERSHIP DUES OCT 2018 - SEPT 2019	40.00
06/19/2018	GENL	40621	SUPERIOR TOWNSHIP CREDIT CARD ACCT	NEW TIRE FOR TRUCK	162.00
06/19/2018	GENL	40622	TRUGREEN PROCESSING CENTER	LAWN SERVICE - APRIL	124.84
06/19/2018	GENL	40623	WEX BANK	FUEL - JUNE 2018	87.64
06/25/2018	GENL	40624	AL'S CLEANING SERVICE	MISC CLEANING @ TOWN HALL	112.00
06/25/2018	GENL	40625	DANIEL SMOKE	DUMP TICKET REIMBURSEMENT	23.00
06/25/2018	GENL	40626	EDWIN MANIER	15 -ELECTRICAL INSPECTIONS	525.00
06/25/2018	GENL	40627	JALEEN WILSON	TRASH PICK-UP MACARTHUR	165.00
06/25/2018	GENL	40628	JESSIE BOWERS	DUMP TICKET REIMBURSEMENT -FINAL PAYMENT	1.00
06/25/2018	GENL	40629	JOHN DIEFENBACHER	57- BUILDING INSPECTIONS	1,995.00
06/25/2018	GENL	40630	PARHELION TECHNOLOGIES	EMAIL - JUNE 2018	5.00
06/25/2018	GENL	40631	PARKWAY SERVICES	PORTAJOHN - SUPERIOR DAYS	215.00
06/25/2018	GENL	40632	PETTY CASH	2018 TAX COLLECTION REGISTER DRAWER LOAN	200.00
06/25/2018	GENL	40633	PITTSFIELD TOWNSHIP	4 - INSPECTIONS MAY 24, 2018	140.00
06/25/2018	GENL	40634	RON PEATRY	MILEAGE REIMBURSEMENT 6/11/18-6/22/18	147.15
06/25/2018	GENL	40635	SPARTAN DISTRIBUTORS INC	TORO MOWER PARTS	451.57
06/25/2018	GENL	40636	STARKS CLEANING LLC	MONTHLY CLEANING SERVICES - TOWN HALL	1,600.00

Check Date	Bank	Check	Vendor Name	Description	Amount
06/25/2018	GENL	40637	STATE OF MICHIGAN	2018 UNCLAIMED PROPERTY - ESCHEATS	34.70
06/25/2018	GENL	40638	SUPERIOR TWP PAYROLL FUND	ADD'L MONEY OWED FOR PENSION	41,895.46
06/25/2018	GENL	40639	TAYLOR CHAPPLE	BOND REFUND - 990 W CLARK ROAD	500.00
06/25/2018	GENL	40640	VISION SERVICE PLAN	VISION INSURANCE - JULY 2018	151.80
06/25/2018	GENL	40641	WALMART COMMUNITY/SYNCB	SUPERIOR DAYS - SHOP SUPPLIES	175.61
06/25/2018	GENL	40642	WASHTENAW COUNTY TREASURER	OVERTIME - MAY 2018	7,021.00
06/25/2018	GENL	40643	WEST STAR PLUMBING & HEATING	REPAIR TOILET IN WOMEN'S RESTROOM IN MTG	497.00
06/25/2018	GENL	40644	WEX BANK	FUEL - JUNE 2018 & SUPERIOR DAYS	481.41
07/10/2018	GENL	40645	DTE ENERGY	STREETLIGHTS - JUNE 2018	6,596.61
07/10/2018	GENL	40646	ABSOPURE WATER COMPANY	COOLER RENTAL - 2018	66.75
07/10/2018	GENL	40647	ANN ARBOR CLEANING SUPPLY	BUILDING SUPPLIES	150.68
07/10/2018	GENL	40648	ARC DOCUMENT SOLUTIONS LLC	BLUE PRINT COPIES	35.17
07/10/2018	GENL	40649	COMCAST	INTERNET/PHONE SERVICES -JUNE 2018	160.70
07/10/2018	GENL	40650	D.R.A.C.O.	MEMBERSHIP DUES SEPT 2018-AUG 2019	75.00
07/10/2018	GENL	40651	DTE ENERGY	APT "1" GAS - JUNE 2018	1,062.93
07/10/2018	GENL	40652	EDWIN MANIER	8-ELECTRICAL INSPECTIONS 6/25/18-7/7/18	280.00
07/10/2018	GENL	40653	FEDEX	OVERNIGHT TO PSI	29.12
07/10/2018	GENL	40654	GIOVANY MURILLO	DUMP TICKET REIMBURSEMENT	34.50
07/10/2018	GENL	40655	HEATHER BROUGHTON	DUMP TICKET REIMBURSEMENT	22.00
07/10/2018	GENL	40656	HOWLETT LOCK & DOOR, INC.	NEW LOCK FOR LAW OFFICE TO GARAGE	263.00
07/10/2018	GENL	40657	JALEEN WILSON	TRASH PICK-UP MACARTHUR	375.00
07/10/2018	GENL	40658	JOHN DIEFENBACHER	36- BUILDING INSPECTIONS 6/25/18-7/7/18	1,260.00
07/10/2018	GENL	40659	LOWE'S	PPE FOR STAFF/OFFICE WINDOW SHADE	108.61
07/10/2018	GENL	40660	LUCAS NURSERIES & LANDSCAPING	GEDDESS ROAD TREES - ROW	3,889.36
07/10/2018	GENL	40661	MAILFINANCE	POSTAGE METER LEASE - 04/24/18-07/23/18	934.59
07/10/2018	GENL	40662	MARGOLIS COMPANIES, INC.	TOP SOIL - OAKBROOK PARK	76.00
07/10/2018	GENL	40663	MICHELLE ARKENS	DUMP TICKET REIMBURSEMENT	28.00
07/10/2018	GENL	40664	MLIVE MEDIA GROUP	JUNE 2018	1,299.82
07/10/2018	GENL	40665	PARKWAY SERVICES	PORTA-JOHN OAKBROOK PARK - JULY 2018	115.00
07/10/2018	GENL	40666	PRINTING SYSTEMS, INC.	ELECTION SUPPLIES, STICKERS, BALLOT INST	754.69
07/10/2018	GENL	40667	ROBERT BUTLER	2018 CONTRACT	1,369.55
07/10/2018	GENL	40668	RON PEATRY	MILEAGE REIMBURSEMENT 6/25/18-7/6/18	154.78
07/10/2018	GENL	40669	SAXON LEE	FUEL REIMBURSEMENT FOR CLASS/TEST	31.50
07/10/2018	GENL	40670	SITEONE LANDSCAPE SUPPLY, LLC	GRASS SEED - OAKBROOK PARK	106.67
07/10/2018	GENL	40671	STAPLES BUSINESS CREDIT	OFFICE SUPPLIES	52.84
07/10/2018	GENL	40672	STEFANI A CARTER PLLC	LEGAL SERVICES - JUNE 2018	1,170.00
07/10/2018	GENL	40673	SUPERIOR TOWNSHIP CREDIT CARD ACCT	DETAIL OF TRUCK	274.99
07/10/2018	GENL	40674	SUPERIOR TWP PAYROLL FUND	CASH TRANSFER 7/12/18 PAYROLL	42,769.95
07/10/2018	GENL	40675	SUPERIOR TWP UTILITY DEPARTMENT	CELL PHONES - JUNE 2018	110.39
07/10/2018	GENL	40676	SWEAT SHOP CUSTOM EMBROIDERY, LLC	MAINTENANCE STAFF UNIFORMS	125.00
07/10/2018	GENL	40677	TERMINIX PROCESSING CENTER	PEST CONTROL - JUNE 2018	87.00
07/10/2018	GENL	40678	VERIZON WIRELESS	HOT SPOT CHARGES - JUNE 2018	80.16
07/10/2018	GENL	40679	WALLACE BRYANT	DUMP TICKET REIMBURSEMENT	9.75
07/10/2018	GENL	40680	WASHTENAW COUNTY TREASURER	2018 CONTRACT - JULY	133,875.00
07/10/2018	GENL	40681	WEX BANK	FUEL -JUNE 2018	178.76

Total Paper Check: 291,396.68

GENL TOTALS:

Total of 90 Checks:	291,396.68
Less 7 Void Checks:	0.00
Total of 83 Disbursements:	291,396.68

Check Date	Bank	Check	Vendor Name	Description	Amount
Bank FIRE FIRE FUND					
Check Type: Paper Check					
06/19/2018	FIRE	23828	BLUE CROSS/BLUE SHIELD-M	MEDICAL INSURANCE 2018	9,189.78
06/19/2018	FIRE	23829	COMCAST	ADD'L OUTLET ADDED AT STATION #1	23.26
06/19/2018	FIRE	23830	CONSUMERS LIFE INSURANCE CO	LIFE INSURANCE 2018	102.15
06/19/2018	FIRE	23831	CORRIGAN OIL COMPANY	183.8 GALLONS DIESEL	487.06
06/19/2018	FIRE	23832	DELTA DENTAL	DENTAL INSURANCE 2018	918.00
06/19/2018	FIRE	23833	NFPA	2018 MEMBERSHIP	1,575.00
06/19/2018	FIRE	23834	PARHELION TECHNOLOGIES	SERVER/ANTI-SPAM/EMAIL - JAN 17	1,920.00
06/19/2018	FIRE	23835	VOID		0.00 V
			Void Reason: Created From Check Run Process		
06/19/2018	FIRE	23836	VOID		0.00 V
			Void Reason: Created From Check Run Process		
06/19/2018	FIRE	23837	PHILIP W. DICKINSON	HEALTH INSURANCE REIMBURSEMENT 2018	152.43
06/25/2018	FIRE	23838	ANN ARBOR WELDING SUPPLY	MEDICAL OXYGEN	91.93
06/25/2018	FIRE	23839	COMCAST	INTERNET/PHONE SERVICES STATION #2 -JJUL	261.85
06/25/2018	FIRE	23840	DINGES FIRE COMPANY	FIRE TOOLS	1,091.54
06/25/2018	FIRE	23841	DTE ENERGY	GAS - STATION #1 JUNE 2018	49.50
06/25/2018	FIRE	23842	MANER COSTERISAN	SINGLE AUDIT ON FEMA GRANT FOR NEW FIRE	8,500.00
06/25/2018	FIRE	23843	MOORE MEDICAL LLC	AUTOPULSE LIFE BAND REPLACEMENT	986.71
06/25/2018	FIRE	23844	PARHELION TECHNOLOGIES	RESTORE PHONE SYSTEM	93.75
06/25/2018	FIRE	23845	PAYETTE SALES & SERVICE, INC.	INSTALLED NEW AUTO EJECT	732.90
06/25/2018	FIRE	23846	RICOH USA, INC	COPIER LEASE -JUNE 2018	182.93
06/25/2018	FIRE	23847	SAFETY- KLEEN CORP.	OIL RECYCLE	120.00
06/25/2018	FIRE	23848	SUPERIOR TWP PAYROLL FUND	CASH TRANSFER 6/28/18 PAY	34,430.37
06/25/2018	FIRE	23849	VISION SERVICE PLAN	VISION INSURANCE - JULY 2018	198.00
06/25/2018	FIRE	23850	WASHTENAW COUNTY HAZMAT AUTHORITY	ANNUAL DUES -2018	500.00
07/10/2018	FIRE	23851	ANN ARBOR CLEANING SUPPLY	STATION SUPPLIES	326.44
07/10/2018	FIRE	23852	AUTO VALUE YPSILANTI	SHOP SUPPLIES - WASHER FLUID TRUCKS	111.41
07/10/2018	FIRE	23853	CARPET EXCHANGE & FLOORS	CARPET - STATION #2	3,442.56
07/10/2018	FIRE	23854	COMCAST	INTERNET/PHONE SERVICES - STATION #1 -JU	190.70
07/10/2018	FIRE	23855	COMSOURCE, INC	MAGNETIC MIC CONVERSION KIT	205.00
07/10/2018	FIRE	23856	CONGDON'S ACE HARDWARE	BUILDING SUPPLIES	16.97
07/10/2018	FIRE	23857	CORRIGAN OIL COMPANY	135 GALLONS DIESEL FUEL	359.60
07/10/2018	FIRE	23858	CUMMINS SALES AND SERVICE	TRUCK PARTS FOR E11-1	271.46
07/10/2018	FIRE	23859	CUMMINS SALES AND SERVICE	REPAIR OF E11-1	8,562.09
07/10/2018	FIRE	23860	DINGES FIRE COMPANY	VULCAN 180 STANDARD SYSTEM	392.89
07/10/2018	FIRE	23861	DTE ENERGY	ELECTRIC & GAS - STATION #2 -JUNE 2018	1,061.42
07/10/2018	FIRE	23862	EMERGENT HEALTH PARTNERS	JULY 2018	1,848.80
07/10/2018	FIRE	23863	SUPERIOR TOWNSHIP CREDIT CARD ACCT	CREDIT CARD - UPS	106.22
07/10/2018	FIRE	23864	SUPERIOR TWP GENERAL FUND	ACCOUNTING FEES 2018	833.33
07/10/2018	FIRE	23865	SUPERIOR TWP PAYROLL FUND	CASH TRANSFER 7/12/18 PAYROLL	34,633.07
07/10/2018	FIRE	23866	TIMOTHY WINTERS	HEALTH INSURANCE REIMBURSEMENT -2018	150.23
07/10/2018	FIRE	23867	VERIZON WIRELESS	CELL PHONES - JUNE 2018	464.38
07/10/2018	FIRE	23868	WASHTENAW COUNTY TREASURER	RADIO MAINTENANCE FEES 2018	960.00
07/10/2018	FIRE	23869	WETPRO, INC	INTERIOR PAINTING OF STATION #2	1,300.00
07/10/2018	FIRE	23870	WEX BANK	FUEL - CHIEF JUNE 2018	189.16
07/10/2018	FIRE	23871	WINDSTREAM	FINAL PAYMENT ON ACCOUNT	147.55
			Total Paper Check:		117,180.44

FIRE TOTALS:

Total of 44 Checks:  
 Less 2 Void Checks:

117,180.44  
 0.00

07/10/2018 01:00 PM  
User: NANCY  
DB: Superior Twp

CHECK REGISTER FOR CHARTER TOWNSHIP OF SUPERIOR  
CHECK DATE FROM 06/19/2018 - 07/16/2018

Check Date	Bank	Check	Vendor Name	Description	Amount
Total of 42 Disbursements:					117,180.44

1:15 PM  
 07/10/18  
 Accrual Basis

Superior Township Utility Department  
 Check Register  
 June 19 through July 16, 2018

Date	Num	Name	Memo	Amount
100 · CASH - O&M				
101 · Checking - Chase 205000485529				
06/19/18	11094	Amazon Capital Services, Inc.	Earplugs & Insect repellent	(65.63)
06/19/18	11095	Ashlee Aragon/Robert Moss	Refund W/S Overpayment - 1520 Dawn	(105.93)
06/19/18	11096	Auto-Wares Group (Auto Value)	Mower Oil	(31.92)
06/19/18	11097	Blue Cross Blue Shield	Medical Insurance - July 18	(5,224.24)
06/19/18	11098	Comcast	Internet - Adm. Bldg. - May18	(145.70)
06/19/18	11099	Commercial Lawnmower	Mower parts	(287.27)
06/19/18	11100	Congdon's Ace Hardware	Misc. Supplies	(4.17)
06/19/18	11101	Consumer's Life Insurance Company	Life Insurance - July 18	(62.43)
06/19/18	11102	Core & Main	Hydrant Extensions & Stopbox Caps	(1,074.40)
06/19/18	11103	Cummins Sales and Service	Battery Replaced - Prospect Pte.	(671.71)
06/19/18	11104	Delta Dental Plan of Michigan	Dental Insurance - July 2018	(526.64)
06/19/18	11105	DTE	Elect. & Gas @ 1799 N. Prospect - May18	(183.48)
06/19/18	11106	Duke's Root Control, Inc.	Root Control Service	(6,916.13)
06/19/18	11107	International Controls & Equipment	Maint. on Front Gate	(175.00)
06/19/18	11108	MailFinance	Folding Machine Lease - May-Jul18	(867.45)
06/19/18	11109	Parhelion Technologies	Replacement check for 2017 services	(6,707.50)
06/19/18	11110	Pitney Bowes	Postage Meter Lease - 2nd/18	(434.37)
06/19/18	11111	Select Portfolio Servicing	Refund W/S Overpayment - 1644 Greenway	(48.44)
06/19/18	11112	Standard Printing	Business Cards & window envelopes	(455.00)
06/19/18	11113	TruGreen	Lawn Maintenance	(214.48)
06/19/18	11114	Weingartz	Hedge Trimmer	(423.96)
06/19/18	11115	Ypsilanti Comm. Utilities Authority	W/S- May 18	(237,803.75)
06/25/18	11116	Badger Meter	Orion Cellular Service Unit - May18	(347.10)
06/25/18	11117	Vision Service Plan	Vision Insurance - Jul18	(107.80)
06/25/18	11118	Wex Bank	Fuel - June 2018	(357.08)
06/25/18	11119	Superior Twp. Payroll Fund	Payroll - 6/28/18	(21,333.72)
07/10/18	EFT	Magic-Wrighter	Monthly Fee - Jun18	(68.42)
07/10/18	11120	American Water Works Association	Annual Dues - 2018-2019	(330.00)
07/10/18	11121	Arbor Inspection Services, LLC	Fire Sprinkler Inspection	(385.00)
07/10/18	11122	AT&T	Booster Sta. Phone - Jun18	(152.88)
07/10/18	11123	Auto-Wares Group (Auto Value)	Misc. Supplies	(16.17)
07/10/18	11124	Badger Meter	Orion Cellular Service Unit - Jun18	(354.44)
07/10/18	11125	Chapter 13 Trustee, Tammy L. Terry	Refund W/S Payment Made in Error	(515.23)
07/10/18	11126	Charter Twp. of Ypsilanti	Use of Clark Road dump station	(34.50)
07/10/18	11127	Comcast	June 2018 - Admin & Maintenance Building	(306.40)
07/10/18	11128	Commercial Lawnmower	Mower Parts	(101.80)
07/10/18	11129	Core & Main	Hydrant Extensions & Stopbox Caps	(2,863.86)



1:15 PM  
07/10/18  
Accrual Basis

Superior Township Utility Department  
Check Register  
June 19 through July 16, 2018

Date	Num	Name	Memo	Amount
07/10/18	11130	Cummins Sales and Service	Maint. - Clark Booster Sta.	(1,276.43)
07/10/18	11131	DTE	Gas/Elec - June 2018	(980.35)
07/10/18	11132	Etna Supply	Meter Supplies	(1,700.50)
07/10/18	11133	General Bank	Replace Check # 10275 - Turned over to Escheats	(14.90)
07/10/18	11134	Home Depot	Misc. Supplies	(93.35)
07/10/18	11135	Ingersoll Rand	Semi-Annual Maintenance on PM T-30 Air Compressor	(712.00)
07/10/18	11136	Mary Burton	Mileage - 06/05-07/05/18	(78.75)
07/10/18	11137	Midwest Maintenance	Yard Restoration for Sewer Replacement - McArthur	(1,200.00)
07/10/18	11138	Millennium Business Systems	Toshiba Copier Lease - Jun18	(279.02)
07/10/18	11139	Paragon Laboratories	Water Samples	(75.00)
07/10/18	11140	Purchase Power	Postage Meter Refill	(500.00)
07/10/18	11141	Sam's Club	Annual Membership Dues 2018 & supplies	(328.30)
07/10/18	11142	Share Corporation	Degreaser	(1,318.71)
07/10/18	11143	Staples Credit Plan	Office Supplies	(153.78)
07/10/18	11144	Starks Cleaning, LLC	Adm. Bldg. Cleaning - Jun18	(400.00)
07/10/18	11145	Stericycle Communications	Answering Service - Jun18	(291.91)
07/10/18	11146	Superior Twp. Payroll Fund	Payroll - 07/12/18	(21,874.72)
07/10/18	11147	Terminix Processing Center	Pest Control	(53.00)
07/10/18	11148	TruGreen	Weed Control - Maint. Bldg.	(567.27)
07/10/18	11149	UIS	Troubleshoot Comm. Failures	(695.00)
07/10/18	11150	Verizon	Cell Phones - Jun18	(558.46)
07/10/18	11151	Windstream	Phones - Maint. Fac. - Final billing	(230.12)
07/10/18	11152	Ypsilanti Comm. Utilities Authority	W/S Purch. - AR Properties - Jun18	(376.67)
Total 101 · Checking - Chase 205000485529				(323,462.24)
Total 100 · CASH - O&M				(323,462.24)
120 · CASH - CAPITAL RESERVE				
125 · CR Chkg. - Chase 639918234				
125-YC · Cap. Reserves Checking - YCUA				
07/10/18	652	Bostwick Co., Inc.	Oakbrook Concrete Restoration - New Hydrants	(2,490.00)
07/10/18	653	Midwest Maintenance	Yard Restoration for New Hydrants	(1,200.00)
Total 125-YC · Cap. Reserves Checking - YCUA				(3,690.00)
Total 125 · CR Chkg. - Chase 639918234				(3,690.00)
Total 120 · CASH - CAPITAL RESERVE				(3,690.00)
TOTAL				<u>(327,152.24)</u>



FYI

## Public Hearing Notice City of Ypsilanti Zoning Board of Appeals

Wednesday, July 25, 2018, 7:00 p.m.  
Council Chambers, City Hall  
1 S Huron, Ypsilanti, MI 48197

A public hearing will be held by the Zoning Board of Appeals at their regular meeting to consider the following item:

### **Variance Requests: Dimensional Variances for 539 S Huron and 569 S Huron**

The Zoning Board of Appeals will hear an application, hold a public hearing, and make a determination regarding the following variance requests:

- From §122-477(H), Frontage Buildout, to permit a building with less than 50% of frontage buildout.
- From §122-477, Private Frontages, to permit a frontage to be constructed that does not adhere to the provisions of §122-484.

The properties in question are currently zoned GC, General Corridor, with a building type of Single-Story Commercial. The addresses, parcel numbers, and legal descriptions are:

- Address: 539 S. Huron  
Parcel Number: 11-11-37-101-002  
Legal Description: BEGINNING AT THE INTERSECTION OF THE CENTERLINE OF MONROE STREET (NOW ABANDONED) AND THE CENTERLINE OF HURON STREET THENCE N 31 DEG 00' 48" E ALONG THE CENTERLINE OF HURON STREET 126.52 FT THENCE N 72 DEG 53' 48" E ALONG THE S RIGHT-OF-WAY OF KRAMER ST 167.67 FT THENCE S17 DEG 06' 12" E 132.00 FT THENCE S 72 DEG 53'48" W 138.61 FT THENCE S 50 DEG 49' 47" E 152.92 FT THENCE S31 DEG 02' 51" W 121.83 FT THENCE N 60 DEG 30' 47" W 269.07 FT THENCE ALONG THE CENTERLINE OF HURON STREET N31 DEG 00' 48" E 90.67 FT TO THE POINT OF BEGINNING EXCEPT THAT PORTION TAKEN DEEDED OR USED FOR HIGHWAY PURPOSES.
- Address: 569 S. Huron  
Parcel Number: 11-11-37-101-006  
Legal Description: COMM AT THE INTER OF CL OF HURON AND MONROE; TH S 31.00'48" W 91.51'; TH S 60.26'12" E 60' + TO PT OF BEG; TH S 60.26'12" E 210' +; TH S31.00'48" W 179.39'; TH N 58.59'12" W 86.00'; TH S31.00'48" W 138' +; TH N 27.38'50" W 50'+; TH N 07.41'52" E 111.81'; TH N17.57'08" E 190'+ TO PT OF BEG. 41,765 SQ FT

Zoning Board of Appeals agendas and packets, including applications, staff reviews, and digital plans when possible, are available at [cityofypsilanti.com/ZBA](http://cityofypsilanti.com/ZBA). For further information, please call **734-483-9646** or email Cynthia Kochanek, Preservation Planner, at [ckochanek@cityofypsilanti.com](mailto:ckochanek@cityofypsilanti.com). For a full calendar of City events, please go to our website at [cityofypsilanti.com/calendar.aspx](http://cityofypsilanti.com/calendar.aspx).

The City invites all interested persons to attend this meeting or to send written comments to the City of Ypsilanti, Community & Economic Development Department, One South Huron Street, Ypsilanti, Michigan 48197. The City of Ypsilanti will provide necessary reasonable auxiliary aids and services, such as signers for the hearing impaired, Limited English Proficiency (LEP) services, and audios of printed materials being considered at the meeting. Individuals requiring auxiliary aids or services should provide two (2) days' notice to the City, and contact the City by writing the City Clerk's Office, One South Huron Street, Ypsilanti, Michigan 48197; or by calling the Clerk's Office at (734) 483-1100.

Frances McMullan  
City Clerk

**LANDLORDS, PLEASE POST THIS  
INFORMATION FOR YOUR TENANTS.**



FYI

**Public Hearing Notice  
City of Ypsilanti Planning Commission**

**Wednesday, 15 August 2018, 7:00 p.m.  
Council Chambers, City Hall  
1 S Huron, Ypsilanti, MI 48197**

A public hearing will be held by the Planning Commission at their regular meeting to consider the following item:

**Special Use Permit: 11 N Normal St: more than 4 dwelling units**

The Planning Commission will hear a presentation, hold a public hearing, and make a determination regarding an application for a special use permit at 11 N Normal St. The parcel is currently zoned **CN, Core Neighborhood**. The applicant is requesting a special use permit to resume the use as a multiple family dwelling with 5 units. The address, parcel number, and legal description of the parcel are: 11 N Normal: 11-11-40-431-011, N 50 FT OF S 215 FT OF E 155.5 FT OF A PARCEL OF LAND LYING AT NW COR NORMAL AND CONGRESS STS. **This item has been moved from its originally scheduled Planning Commission Meeting on July 18, 2018.**

Planning Commission agendas and packets, including applications, staff reviews, and digital plans, are available at [cityofypsilanti.com/PlanningCommission](http://cityofypsilanti.com/PlanningCommission). For further information, please call **734-483-9646** or email Bonnie Wessler, City Planner, at [bwessler@cityofypsilanti.com](mailto:bwessler@cityofypsilanti.com). For a full calendar of City events, please go to our website at [cityofypsilanti.com/calendar.aspx](http://cityofypsilanti.com/calendar.aspx).

The City invites all interested persons to attend this meeting or to send written comments to the City of Ypsilanti, Community & Economic Development Department, One South Huron Street, Ypsilanti, Michigan 48197. The City of Ypsilanti will provide necessary reasonable auxiliary aids and services, such as signers for the hearing impaired, Limited English Proficiency (LEP) services, and audios of printed materials being considered at the meeting. Individuals requiring auxiliary aids or services should provide two (2) days' notice to the City, and contact the City by writing the City Clerk's Office, One South Huron Street, Ypsilanti, Michigan 48197; or by calling the Clerk's Office at (734) 483-1100.

Frances McMullan  
City Clerk

**LANDLORDS, PLEASE POST THIS  
INFORMATION FOR YOUR TENANTS.**