

**CHARTER TOWNSHIP OF SUPERIOR
REGULAR BOARD MEETING
SUPERIOR CHARTER TOWNSHIP HALL
3040 N. PROSPECT, YPSILANTI, MI 48198
APRIL 18, 2016
7:00 p.m.
AGENDA**

1. CALL TO ORDER
2. PLEDGE OF ALLEGIANCE
3. ROLL CALL
4. ADOPTION OF AGENDA
5. APPROVAL OF MINUTES
 - a. Regular Meeting of March 21, 2016
6. CITIZEN PARTICIPATION
7. PRESENTATIONS AND PUBLIC HEARINGS
 - a. Road Commission Annual Meeting
 - b. AATA Service Upgrades Starting May 1
8. REPORTS
 - a. Supervisor
 - b. Departmental Reports: Building Department, Fire Department, Ordinance Officer, Park Commission Minutes, Sheriff's Report, Utility Department
9. COMMUNICATIONS
 - a. Letter from the Parks and Recreation Commission RE: Pedestrian Crosswalk at Fireman's Park
 - b. Letter from Parks Administrator Juan Bradford, Building Healthy Communities Grant
 - c. Letter from Parks Administrator Juan Bradford, Kelly Miller Circus August 13, 2016
10. UNFINISHED BUSINESS
 - a. Ordinance 174-18 Sutton Ridge-Redwood Acquisition LLC, Area Plan Amendment
11. NEW BUSINESS
 - a. Appointment of Parks Commissioner
 - b. Utility Department Purchase of Mower
 - c. Resolution 2016-06, Brookside Judgment
 - d. Resolution 2016-07, Butler Side Street Maintenance Agreement
 - e. Resolution 2016-08, Township Hall Staff Summer Hours
 - f. Farmers Market at Dixboro Village Green, Transient and Amusement Enterprises Application
 - g. Washtenaw County Water Resources Commission Invoice for Geddes Ridge Drain District Improvements
 - h. Ann Arbor Spark 2015 Due

- i. Final Payment to United Resources for Video Inspection of Sanitary Sewer pipes for the SAW grant

12. BILLS FOR PAYMENT AND RECORD OF DISBURSEMENTS
13. PLEAS AND PETITIONS
14. ADJOURNMENT

David Phillips, Clerk, Superior Township, 3040 N. Prospect, Ypsilanti, MI 48198
Telephone: 734-482-6099; Email: davidphillips@superior-twp.org

There will be a meeting of the Superior Township Election Commission immediately after the Board meeting.

**SUPERIOR CHARTER TOWNSHIP BOARD
REGULAR MEETING
MARCH 21, 2016
PROPOSED MINUTES
PAGE 1**

1. CALL TO ORDER

The regular meeting of the Superior Charter Township Board was called to order by the Supervisor Kenneth Schwartz at 7:00 p.m. on March 21, 2016, at the Superior Township Hall, 3040 North Prospect, Ypsilanti, Michigan.

2. PLEDGE OF ALLEGIANCE

The Supervisor Schwartz led the assembly in the pledge of allegiance to the flag.

3. ROLL CALL

The members present were Ken Schwartz, David Phillips, Nancy Caviston, and Alex Williams. Treasurer McKinney and Trustees Green and Lewis were absent.

4. ADOPTION OF AGENDA

It was moved by Caviston seconded by Williams, to adopt the agenda with the additions Washtenaw County Parks Acquisition of 53 acres in Section 33 under Presentations and Closed Session to Discuss Redwood Rezoning under item b. of Unfinished Business.

The motion carried by unanimous voice vote.

5. APPROVAL OF MINUTES

A. REGULAR MEETING OF FEBRUARY 16, 2016

It was moved by Caviston, seconded by Williams, to approve the minutes of the regular Board meeting of February 16, 2016, as presented.

The motion carried by a unanimous voice vote.

6. CITIZEN PARTICIPATION

A. CITIZEN COMMENTS

Martha Kern- Boprie explained that the Parks Commission recommended the candidate for the vacant Parks Commissioner position without interviews. She requested that the Board defer action on the appointment until after the Parks Commission both candidates.

Tracey Pitt inquired if the Valbridge study is going to be discussed tonight. Supervisor Schwartz replied that it has not yet been completed.

**SUPERIOR CHARTER TOWNSHIP BOARD
REGULAR MEETING
MARCH 21, 2016
PROPOSED MINUTES
PAGE 2**

Kathleen Hubbs, inquired if the Valbridge study is going to be made public.

Lynn Rose, president of the Lakeview Condo Owners Association inquired about drivers speeding down Berkshire and repairs to the public portion of Lakeview Drive.

Supervisor Schwartz indicated that April's Board meeting may be moved from April 18 to April 19 or April 20.

Albertina Baker, who resides in Bromley condos, said she supports the Redwood Apartment proposal as finishing Phase 2 will benefit the condos by adding fees.

Ken Hubbs, inquired about removing dead trees along Geddes Road that may fall on the road.

7. PRESENTATIONS

A. COUNTY PARKS AND RECREATION

Jack Smiley of the Southeast Michigan Land Conservancy and Tom Freeman, Washtenaw County Parks made a presentation to the Board about the County Parks purchasing 53 acres from the SLMC for use as a passive recreation park. Parks and Recreation found the property to be high quality for preservation and hope to add soft walking trails that may connect to other walking trails in the area. Board members had questions and comments. Clerk Phillips indicated that he felt it was important to retain the easement for the sewer line through the property as it is an important link to provide sewer service to Prospect Pointe and the former Meadows subdivisions and other lands planned for development in the area. The sewer line is not needed now but may be needed in the future. Tom Freeman indicated that the County is aware of the easement and intends to preserve the easement.

8. REPORTS

A. SUPERVISOR REPORT

Supervisor Schwartz reported on the following: Last Wednesday, the Township and the Attorney General obtained judgments against the Fairfax Manor, 1900 N. Prospect Road, assisted living facility. The judgments will require buildings 1, 2 and 3 to be vacated and cannot be reopened and operated unless properly licensed by the State. The current owner is prohibited from obtaining a license for a period of five years. The building must be repaired, be inspected by the Township and comply with all building codes. The Township engineers completed a feasibility study on the proposed new fire station No. 2 at Geddes and Prospect. Board members will be provided with a copy of the study. There are two drain issues in the Township. There was a Board of Determination on the Geddes Ridge drain district. There is a meeting with the Water

**SUPERIOR CHARTER TOWNSHIP BOARD
REGULAR MEETING
MARCH 21, 2016
PROPOSED MINUTES
PAGE 3**

Resources Commission on March 22, 2016. There is expected to be a levy of about \$200 per year for 10 years for each of the 153 homes in Geddes Ridge. There was also a Board of Determination on the Bazely Foster drain district with an expected one-time levy of about \$18.00 for each of the homes in the district. The Township acquired two homes in the Harvest Lane subdivision from the County Tax sale. Both have been sold to the Habitat for Humanity, who completed the renovation on them. The Humane Society has requested the Township contribute \$66,000 towards the operation of the shelter. Woodside subdivision has been purchased by investors. A home builder has expressed an interest in purchasing the remaining lots from the investor and finishing the remaining 40 homes in Phase 1 and 90 homes in Phase 2. Supervisor Schwartz and Treasurer McKinney made a presentation to CTAP and requested \$10,000 for tree removal and signage, which requires a \$2,500 match from the Township. Supervisor Schwartz indicated that due to scheduling conflicts, he may reschedule the April 18 Board meeting until April 19 or April 20.

B. DEPARTMENT REPORTS: BUILDING DEPARTMENT, FIRE DEPARTMENT, ORDINANCE OFFICER REPORT, PARK COMMISSION MINUTES, SHERIFF'S REPORT, UTILITY DEPARTMENT

It was moved by Caviston, seconded by Williams, that the Superior Township Board receive all reports.

The motion carried by unanimous voice vote.

8. COMMUNICATIONS

A. ELLEN KURATH, CALCIUM CHLORIDE DUST CONTROL

Ellen Kurath provided a letter to the Board in which she recommended the Township use calcium chloride instead of brine for dust control.

It was moved by Caviston, seconded by Williams, for the Board to receive Ellen Kurath's communication.

9. UNFINISHED BUSINESS

A. RESOLUTION 2016-01, ORDINANCE NO. 190, ADOPTION OF THE 2012 INTERNATIONAL FIRE CODE

**SUPERIOR CHARTER TOWNSHIP BOARD
REGULAR MEETING
MARCH 21, 2016
PROPOSED MINUTES
PAGE 4**

Clerk Phillips indicated that no comments were received since the first reading of the ordinance and the draft ordinance has not changed from the first reading.

Supervisor Schwartz explained that it was necessary for the Township to adopt and operate under the 2012 International Fire Code.

It was moved by Caviston, seconded by Williams, for the Board to approve the following resolution:

**CHARTER TOWNSHIP OF SUPERIOR
WASHTENAW COUNTY, MICHIGAN**

RESOLUTION ESTABLISHING ORDINANCE NO: 190

Fire Prevention Code of the Charter Township of Superior

Resolution Number: 2016-01

Date: February 16, 2016

WHEREAS, the Charter Township of Superior is currently operating under Superior Township Ordinance 154, the "Fire Prevention Code of the Charter Township of Superior, Ordinance No. 154", passed by the Superior Township Board of Trustees October 15, 2001; and,

WHEREAS, fire science is an ever evolving subject with amendments and new procedures being adopted as public policy from time to time; and,

WHEREAS, the International Fire Code was updated and modified in 2012 as new rules and procedures were promulgated by the International Code Council thus requiring the repeal and replacement of inconsistent township ordinances thereof.

NOW THEREFORE, BE IT RESOLVED that the Superior Township Board of Trustees hereby introduces Ordinance 190 which shall be known as the "Fire Prevention Code of the Charter Township of Superior".

BE IT FURTHER RESOLVED that upon final approval and adoption, Superior Township Ordinance 154, effective October 15, 2001, is hereby repealed.

CERTIFICATION

**SUPERIOR CHARTER TOWNSHIP BOARD
REGULAR MEETING
MARCH 21, 2016
PROPOSED MINUTES
PAGE 5**

I, David Phillips, the duly qualified Clerk of the Charter Township of Superior, Washtenaw County, Michigan, do hereby certify that the foregoing is a true and correct copy of a resolution adopted at a regular meeting of the Superior Charter Township Board held on _____ and that public notices of said meeting were given pursuant to Act No. 267, Public Acts of Michigan, 1976, as amended.

David Phillips, Superior Township Clerk

The motion carried by a unanimous voice vote

**CHARTER TOWNSHIP OF SUPERIOR
WASHTENAW COUNTY, MICHIGAN**

ORDINANCE NUMBER 190

ORDINANCE FOR THE ADOPTION OF THE 2012 INTERNATIONAL FIRE CODE

AN ORDINANCE ADOPTING THE 2012 EDITION OF THE INTERNATIONAL FIRE CODE, REGULATING AND GOVERNING THE SAFEGUARDING OF LIFE AND PROPERTY FROM FIRE AND EXPLOSION HAZARDS ARISING FROM THE STORAGE, HANDLING AND USE OF HAZARDOUS SUBSTANCES, MATERIALS AND DEVICES, AND FROM CONDITIONS HAZARDOUS TO LIFE OR PROPERTY IN THE OCCUPANCY OF BUILDINGS AND PREMISES IN THE CHARTER TOWNSHIP OF SUPERIOR, WASHTENAW COUNTY; MICHIGAN, PROVIDING FOR THE ISSUANCE OF PERMITS FOR HAZARDOUS USES OR OPERATIONS, REPEALING ORDINANCE NUMBER 154 OF SUPERIOR CHARTER TOWNSHIP AND ALL OTHER ORDINANCES AND PARTS OF THE ORDINANCES IN CONFLICT THEREWITH.

THE CHARTER TOWNSHIP OF SUPERIOR WASHTENAW COUNTY, MICHIGAN ORDAINS:

Section 190.01. Short Title

This Ordinance shall be known and may be cited as the "Fire Prevention Code of the Charter Township of Superior."

Section 190.02. Adoption of Fire Prevention Code

**SUPERIOR CHARTER TOWNSHIP BOARD
REGULAR MEETING
MARCH 21, 2016
PROPOSED MINUTES
PAGE 6**

The International Fire Code, 2012 Edition, including Appendix Chapters A, B, C, D, E and G, (see International Fire Code Section 101.2.1, 2012 edition) as published by the International Code Council, is hereby adopted by reference as an ordinance of the Charter Township of Superior, with the additions, insertions and changes as hereafter provided in Section 190.03; and each and all of the regulations, provisions, conditions, and terms of such International Fire Code are hereby referred to, adopted and made a part hereof as if fully set out in this Ordinance. At least three (3) copies on file in the offices of the Charter Township of Superior,

Section 190.03. Changes in Code

That the following sections are hereby revised:

(A) **Section 101.1 Title.** These regulations shall be known as the Fire Code of Charter Township of Superior, hereinafter referred to as "this code."

(B) **Section 109.4 Violation penalties.** Persons who shall violate a provision of this code or shall fail to comply with any of the requirements thereof or who shall erect, install, alter, repair or do work in violation of the approved construction documents or directive of the fire code official, or of a permit or certificate used under provisions of this code, shall be responsible for a municipal civil infraction, punishable by a fine of not more than five hundred dollars (\$500). Each day that a violation continues after due notice has been served shall be deemed a separate offense.

(C) **Section 111.4. Failure to comply.** Any person who shall continue any work after having been served with a stop work order, except such work as that person is directed to perform to remove a violation or unsafe condition, shall be liable to a fine of not less than one hundred dollars (\$100) or more than five hundred dollars (\$500).

Section 190.04. Geographic Limits

The geographic limits referred to in certain sections of the 2012 International Fire Code are hereby established as follows:

(A) **Section 5704.2.9.6.1** (geographic limits in which the storage of Class I and Class II liquids in above-ground tanks outside of buildings is prohibited): within any residential zoning district in the township, or any non-agricultural zoned lot upon which a dwelling is located

(B) **Section 5706.2.4.4** (geographic limits in which the storage of Class I and Class II liquids in above-ground tanks is prohibited): within any residential zoning district in the township, or any non-agricultural zoned lot upon which a dwelling is located

(C) **Section 5806.2** (geographic limits in which the storage of flammable cryogenic

**SUPERIOR CHARTER TOWNSHIP BOARD
REGULAR MEETING
MARCH 21, 2016
PROPOSED MINUTES
PAGE 7**

fluids in stationary containers is prohibited): within any residential zoning district in the township, or any non-agricultural zoned lot upon which a dwelling is located

(D) **Section 6104.2** (geographic limits in which the storage of liquefied petroleum gas is restricted for the protection of heavily populated or congested areas): within any residential zoning district in the township, or any non-agricultural zoned lot upon which a dwelling is located

Section 190.05. Inconsistent Ordinances Repealed

All ordinances adopting the prior versions of the International Fire Code are repealed, including without limitation Ordinances 131 and 154, and all other ordinances or parts of ordinances in conflict herewith are hereby repealed.

Section 190.06. Saving clause

(A) That if any section, subsection, sentence, clause or phrase of this ordinance is, for any reason, held to be unconstitutional, such decision shall not affect the validity of the remaining portions of this ordinance. The Township Board hereby declares that it would have passed this ordinance, and each section, subsection, clause or phrase thereof, irrespective of the fact that anyone or more sections, subsections, sentences, clauses and phrases be declared unconstitutional.

(B) That nothing in this Ordinance or in the International Fire Code hereby adopted shall be construed to affect any suit or proceeding impending in any court, or any rights acquired, or liability incurred, or any cause or causes of action acquired or existing, under any act or ordinances hereby repealed as cited in Section 2 of this Ordinance; nor shall any just or legal right or remedy of any character be lost, impaired or affected by this Ordinance.

Section 190.07. Effective Date; Publication

This Ordinance shall be published in the Ann Arbor News, a newspaper having general circulation in said Township and shall become effective thirty (30) days after publication.

YEAS: Schwartz, Phillips, Caviston, Williams

NAYS: None

ABSENT: McKinney, Green, Lewis

Ordinance Declared Adopted on March 21, 2016.

Kenneth Schwartz
Township Supervisor

CERTIFICATE OF ADOPTION AND PUBLICATION

I, David Phillips, the duly elected Clerk of the Charter Township of Superior, certify that the foregoing ordinance is a true and correct copy of the ordinance enacted by the Township Board of the Charter Township of Superior on March 21, 2016 and published in a newspaper, circulated in the Charter Township of Superior on _____, 2016.

David Phillips, Clerk
Charter Township of Superior

B. ORDINANCE 174-18, SUTTON RIDGE – REDWOOD ACQUISITION LLC, AREA PLAN AMENDMENT

Supervisor Schwartz indicated that the Board was going to go into closed session and that the Board was not going to take any action on the Ordinance.

It was moved by Caviston, seconded by Williams to postpone action on Ordinance 174-18 until the Board's regularly scheduled meeting of April 18, 2016.

CLOSED SESSION TO DISCUSS SUTTON RIDGE-REDWOOD REZONING

It was moved by Caviston, seconded by Williams, for the Board to go into closed session to meet with the Township Attorney to discuss the Redwood rezoning

Ayes: Schwartz, Phillips, Caviston, Williams

Nays: None

Absent: Caviston, McKinney, Green

The motion carried. At 8:05 p.m., the Board exited the Board Room to go into closed session.

The Board returned to the Board Room at 8:35 p.m.

It was moved by Caviston, seconded by Williams, for the Board to return to open session.

Ayes: Phillips, Caviston, Williams, Schwartz

**SUPERIOR CHARTER TOWNSHIP BOARD
REGULAR MEETING
MARCH 21, 2016
PROPOSED MINUTES
PAGE 9**

Nays: None

Absent: Green, Lewis, McKinney

The motion carried. The Board returned to open session at 8:37 p.m.

It was moved by Caviston, seconded by Williams, for the Board to approve the minutes of the closed session, which were discussed for approval during the closed session.

The motion carried by unanimous voice vote.

10. NEW BUSINESS

A. PARKS AND RECREATION COMMISSIONER APPOINTMENT

It was moved by Williams, seconded by Caviston, for the Board to send the recommendation back to the Parks Commission.

The motion carried by unanimous voice vote.

B. PARKS AND RECREATION BUILDING HEALTHY COMMUNITIES GRANT

Parks Director Juan Bradford provided a letter to the Board and made a short presentation about the Building Healthy Communities Grant. The Parks Department has been approved by Michigan Parks and Recreation Association for \$24,000 for improvements to Fireman's Park and \$10,000 to hire staff to operate a wellness program. The program will provide fun, fitness and games for youth and walking for adults. There is no match required for this grant. The Parks Commission is requesting the Township Board's support of the grant prior to their acceptance of the grant.

It was moved by Williams, seconded by Caviston, for the Board to support the decision for the Parks Department to accept the MParks grant for the COAP and WWE programs.

The motion carried by unanimous voice vote.

C. RESOLUTION 2016-03, FEES PERTAINING TO ZONING ORDINANCE

Clerk Phillips provided a memo to the Board and explained the process for collecting application fees and escrow fees when an applicant applies for actions pertaining to the zoning ordinance. He indicated that the process has been cumbersome and inefficient. A number of years ago some of the applicants generated considerable costs to the Township for planning and engineering review fees and then disappeared. The Township lost thousands of dollars on these accounts. The

**SUPERIOR CHARTER TOWNSHIP BOARD
REGULAR MEETING
MARCH 21, 2016
PROPOSED MINUTES
PAGE 10**

proposed amendment attempts to prevent this from happening again by requiring increased escrow deposits and that the applicant maintain a minimum amount of escrow. Escrow deposits are pass-through costs and any monies not used are returned to the applicant.

The following resolution was moved by Williams, seconded by Caviston:

**SUPERIOR CHARTER TOWNSHIP
Washtenaw County, Michigan**

**A Resolution to Amend Fees Pertaining to the
Superior Charter Township Zoning Ordinance
March 21, 2016
Resolution 2016-03**

WHEREAS, this Board is authorized by the Zoning Ordinance of the Charter Township of Superior to set fees by resolution for various matters arising in the course of administration of the Zoning Ordinance to defray the cost of processing and evaluating applications, permits and requests; and

WHEREAS, this Board has reviewed the fees previously in effect and has found that they are in need of revision; and

LET IT THEREFORE BE RESOLVED that the Charter Township of Superior, Washtenaw County, Michigan, does hereby amend the fee schedule adopted on January 19, 2010, for

1. APPLICATION FEE REQUIRED

An application fee is required to cover the fixed costs and expenses incurred by the Township for processing of applications for planning review, engineering review, construction inspection and other actions as applicable. These fees are used to cover costs such as 1) The cost of the Planning Commission meetings; 2) Mailing and publication of notices; 3) Maintain the accounting of and processing payments to professionals and consultants; 4) In-house staff time for review of plans, development agreements, performance guarantees, etc.

Application fees are non-refundable.

2. ESCROW ACCOUNT ESTABLISHED

An escrow fund shall be established whenever an application is submitted. Escrow funds are used to defray anticipated variable costs and expenses incurred by the Township where professional input, study or review is desired before a final decision is made. This includes the Township consultants' engineering, planning, legal reviews and other costs as appropriate. All

**SUPERIOR CHARTER TOWNSHIP BOARD
 REGULAR MEETING
 MARCH 21, 2016
 PROPOSED MINUTES
 PAGE 11**

escrow funds shall be deposited in a non-interest bearing account and are refundable if they are not used.

3. ADDITIONAL DEPOSITS TO ESCROW FUND REQUIRED

Whenever the escrow account falls below a specific level, the applicant will be notified in writing and requested to submit additional escrow. For projects that require a minimum escrow deposit of \$2,500, if the escrow falls below \$1,000, the applicant will be required to deposit a minimum of \$2,500 plus an additional application fee. For projects at the engineering review stage or the construction inspection stage, if the escrow falls below \$5,000, the applicant will be required to deposit \$5,000 plus an additional application fee. If the deposit is not made in a timely manner, the Township may stop further reviews and Township work on the project until the requested deposit is made (See Superior Township Zoning Ordinance Section 1.12, B, 3, b). Any account balance remaining upon completion of the project and acceptance of the record plans will be returned to the applicant.

4. APPLICATION FEES AND MINIMUM ESCROW DEPOSITS REQUIRED

The following fees and minimum escrow deposits shall be paid by the petitioner to the Superior Charter Township Treasurer at the time of submittal of an application for each of the following. The Township may reduce or waive the escrow deposit and/or the application fee if it determines the project will require minimal review or application work.

Planning Commission Review	Escrow Deposit	Application Fee	Total
Area Plan/Rezoning for Special District*	\$5,000	\$900	\$4,400
Site Plan – Preliminary	\$5,000	\$900	\$4,400
Site Plan – Final	\$5,000	\$900	\$4,400
Site Plan – Revised	\$2,500	\$300	\$1,400
Major/Minor Change Determination by the PC	\$2,500	NA	\$ 500
Minor Site Plan Review	\$2,500	\$100	\$1,500
Application Review	\$2,500	NA	\$1,500
Extension of Site Plan	\$2,500	NA	\$1,500
Rezoning Petition, Other than a Special District	\$2,000	\$500	\$1,500

**SUPERIOR CHARTER TOWNSHIP BOARD
 REGULAR MEETING
 MARCH 21, 2016
 PROPOSED MINUTES
 PAGE 12**

Conditional Use Permit	\$2,500	\$500	\$1,500
Additional escrow when required	Either \$2,500 or \$5,000	\$100 for each \$2,500 of added escrow	\$2,600
Zoning reviews for new homes, additions, agricultural buildings, property divisions and re-descriptions	\$2,500 if there is a need for consultant review	\$50	\$50 or \$1,050

*Includes Major Change Amendments to previously approved Area Plans

Engineering Review	Escrow Deposit	Application fee
At the time of submittal of detailed construction plans, specifications, and detailed estimates of total costs of the proposed construction and improvements, the applicant shall make a deposit in the project escrow account.		
Residential	1 ½% of project cost plus \$1 per du	\$500
Non-residential	1 ½ % of project cost plus \$1 per 1,500 s.f. of bldg. size	\$500
Additional escrow when required	\$5,000 minimum	\$200 for each added \$5,000

Engineering Inspection	Escrow Deposit	Application fee
-------------------------------	-----------------------	------------------------

**SUPERIOR CHARTER TOWNSHIP BOARD
REGULAR MEETING
MARCH 21, 2016
PROPOSED MINUTES
PAGE 13**

<p>The review escrow shall cover the costs of actual engineering inspection and any application engineering time incurred by the Township's engineers in association with the project.</p> <p>The extent of inspection and field engineering required may be determined by the Township's engineer based upon the contractor's performance and the applicant's engineering involvement. The costs associated with any field design changes, reviews, evaluations or interpretations of the plans due to discrepancies evolving from the construction operation shall be deducted from the inspection escrow accounts.</p>	<p>Established by Township Engineer</p>	<p>\$500</p>
<p>Additional deposit to escrow account</p>	<p>\$5,000 minimum</p>	<p>\$200 for each added \$5,000</p>

5. MISCELLANEOUS FEES

A ZONING BOARD OF APPEALS PETITION

At the time of filing an appeal to the Zoning Board of Appeals, application fees shall be paid by the petitioner to the Superior Charter Township Treasurer as follows: Appeals brought by the owner of a single-family dwelling and involving a variance request regarding "Density and Height Regulations" for one such dwelling: \$175.00. Any other appeal: \$500.00. The Township may require the applicant establish an escrow account when the Township determines review is required by the planner, engineer, attorney or other consultants. The amount of escrow shall be determined by the Township but shall be a minimum of \$1,500. As with all escrow funds, any monies not used shall be returned to the applicant.

B. SPECIAL MEETING OF THE TOWNSHIP BOARD

At the time of filing a request with the Township Clerk for a special meeting of the Township Board, an application fee of \$600.00 shall be paid by the requester to the Superior Charter Township Treasurer. If the Board determines for any reason that special meeting cannot be held,

**SUPERIOR CHARTER TOWNSHIP BOARD
REGULAR MEETING
MARCH 21, 2016
PROPOSED MINUTES
PAGE 14**

\$450.00 of the \$600.00 application fee shall be refunded, with the remaining portion of the fee to be retained by the Township for application costs.

C. SPECIAL MEETING OF THE TOWNSHIP PLANNING COMMISSION

At the time of filing a request with the Township Clerk for a special meeting of the Township Planning Commission, an application fee of \$750.00 shall be paid by the requester to the Superior Charter Township Treasurer. If the Planning Commission determines for any reason the special meeting cannot be held, \$650.00 of the \$750.00 application fee shall be refunded, with the remaining portion of the fee to be retained by the Township for application costs.

D. PRE-APPLICATION CONSULTANT MEETING

At the time of scheduling a pre-application meeting with the Township Planner, an application fee of \$100.00 shall be paid by the applicant to the Superior Charter Township Treasurer. If additional meetings are requested, an additional application fee of \$75.00 per meeting shall be paid.

E. PRE-APPLICATION REVIEW

Before an application for rezoning, conditional use or site plan review is filed, the petitioner may request a pre-application review by the Township's planner and/or engineer. An application fee of \$500.00 shall be paid by the applicant to the Superior Charter Township Treasurer before such a review is undertaken.

F. TOWNSHIP ADMINISTRATION

The Township shall maintain accurate accounting records of all funds received and all funds expended. Upon request by the applicant, the Township shall provide a statement of all funds received and expended.

G. PUBLICATION AND EFFECTIVE DATES

This resolution and fee schedule shall become effective immediately upon publication in MLive's Ann Arbor edition, aka, the Ann Arbor News, a newspaper of general circulation within the Township on 2016.

CERTIFICATION

**SUPERIOR CHARTER TOWNSHIP BOARD
REGULAR MEETING
MARCH 21, 2016
PROPOSED MINUTES
PAGE 15**

I, David Phillips, the duly qualified Clerk of the Charter Township of Superior, Washtenaw County, Michigan, do hereby certify that the foregoing is a true and correct copy of a resolution adopted at a regular meeting of the Superior Charter Township Board held on March 21, 2016 and that public notices of said meeting were given pursuant to Act No. 267, Public Acts of Michigan, 1976, as amended.

The motion carried by unanimous voice vote and the resolution was adopted.

D. RESOLUTION 2016-04, SALARY INCREASE FOR ELECTION WORKERS

Clerk Phillips presented a memo to the Board and explained that he is having difficulty recruiting election workers. He has surveyed nearby communities and the proposed salary increases will be comparable with the other communities.

The following resolution was moved by Caviston, seconded by Williams:

**CHARTER TOWNSHIP OF SUPERIOR
WASHTENAW COUNTY, MICHIGAN**

**RESOLUTION TO INCREASE THE SALARIES FOR SUPERIOR TOWNSHIP
ELECTION WORKERS**

Resolution Number: 2016-04

Date: March 21, 2016

WHEREAS, as required by law, the Clerk of the Charter Township of Superior Township is responsible to conduct elections; and,

WHEREAS, in order to properly conduct elections it is essential to hire qualified and competent election workers; and,

WHEREAS, election workers in Superior Township are currently paid \$10.00 per hour and chairpersons are paid \$12.00 per hour; and,

WHEREAS, the Clerk of Superior Township has surveyed other communities in the area and determined the proposed salary increase is commensurate with what other communities are already paying their election workers; and,

**SUPERIOR CHARTER TOWNSHIP BOARD
REGULAR MEETING
MARCH 21, 2016
PROPOSED MINUTES
PAGE 16**

WHEREAS, since the enactment of the election consolidation law (PA 298 of 2003), there are fewer elections per year, which results in reduced annual salary costs to conduct elections; and

WHEREAS, salaries for election workers are funded by GL 101-191-703.000, which was budgeted for \$20,000 for FY2016 and to date, about \$6,000 has been expended from this activity and there are adequate funds in the budget to pay for the proposed salary increase; and

NOW THEREFORE, BE IT RESOLVED, that the Superior Township Board of Trustees hereby approves increasing the salaries to \$11.00 per hour for an election worker, \$12.00 per hour for a co-chair and \$13.00 per hour for a chairperson, effective immediately.

The motion carried by unanimous voice vote. The resolution was adopted.

E. FIRE STATION NO. 1 LIGHT REPLACEMENT

Fire Chief Chevrette was present and provided a proposal from A & N Electric to replace indoor can lighting in the day room and sleeping room of Fire Station No. 1 at a cost of \$5,669.28.

He said the lights were part of a larger lighting upgrade that was never completed.

It was moved by Caviston, seconded by Williams, for the Board to approve the proposal from A & N Electric to replace indoor can lighting in the day room and sleeping room of Fire Station No. 1 at a cost not to exceed \$5,669.28.

The motion carried by unanimous voice vote.

F. RESOLUTION 2015-05 PRESERVATION OF 53 ACRES IN SECTION 33

Board member discussed the issue.

The following resolution was moved by Caviston, seconded by Williams:

**SUPERIOR CHARTER TOWNSHIP
WASHTENAW COUNTY, MICHIGAN**

**SUPERIOR CHARTER TOWNSHIP BOARD
REGULAR MEETING
MARCH 21, 2016
PROPOSED MINUTES
PAGE 17**

**A RESOLUTION OF SUPPORT FOR THE COUNTY PARKS NATURAL AREA
PRESERVATION PROGRAM ACQUISITION OF 53 ACRES IN SECTION 33**

Resolution Number: 2016-05

Date: March 21, 2016

WHEREAS, In an email communication the Washtenaw County Parks and Recreation Commission indicated that it was interested in acquiring in fee a 53 acre parcel in section 33 through their Natural Areas Preservation Program (NAPP).

WHEREAS, the parcel is located at 325 E. Clark Road (J-10-33-400-029) in section 33 and contains old growth forest, steep slopes, wetlands, remnant prairie habitat and a stream corridor which runs through the property and connects to the LeFurge Woods Nature Preserve to the north; and,

WHEREAS, The Superior Township Parks Commission voted to support and recommend County acquisition of this property at their meeting held on February 22, 2016; and,

WHEREAS, plans include establishing a trail to connect to the Superior Greenway Nature Trail which leads to Township Hall, with a possible connection to the County's Border-to-Border Trail; and,

WHEREAS, township utility easements on the property would remain in effect for potential future water and sewer lines; and,

WHEREAS, Washtenaw County Ordinance No. 128 requires that properties considered for acquisition through the NAPP be reviewed by the local unit of government.

WHEREAS, without being specific to location, the Washtenaw County Parks and Recreation Commission will make available in the future a small area of land along Clark Road to relocate an existing sanitary pump station. The area to be determined by the mutual consent of the Washtenaw County Parks and Recreation Commission and Superior Township; and,

WHEREAS, the Washtenaw County Parks and Recreation Commission and Superior Township agree to rezone the property from Planned community (PC) to Recreation/Conservation (RC).

THEREFORE, the Superior Township Board agrees that the 53-acre parcel at 325 E. Clark Road, identified in the Washtenaw County Parks and Recreation Commission communication dated January 20, 2016, is suitable for acquisition and preservation through the Washtenaw County Natural Areas Preservation program. The Board further agrees that the parcel contains significant natural features and would encourage the extension of trails from the Border-to-

**SUPERIOR CHARTER TOWNSHIP BOARD
REGULAR MEETING
MARCH 21, 2016
PROPOSED MINUTES
PAGE 18**

Border Trail to the Superior Greenway and the dedication of a small parcel of land to relocate an existing pump sanitary station.

The motion carried by unanimous voice vote. The resolution was adopted.

G. BROMLEY PARK REQUEST TO WAIVE UTILITY MAINTENANCE FEE

The Development Agreement for the Bromley Park contains a provision for the community association to be responsible for an annual utility maintenance fee to cover the cost of additional maintenance to the sewer system and maintenance path. The Township enacted a procedure for the community association to request that the Township waive the fee.

In a letter dated February 18, 2015, the community association requested the Township waive the fee in the amount of \$3,224.43.

It was move by Caviston, seconded by Williams that the Board waive the Bromley Park utility maintenance fee for 2016 in the amount of \$3,224.43.

The motion carried by unanimous voice vote.

H. RESOLUTION OF SUPPORT ROBERT TETENS FOR ROBERT TETENS BY APPOINTED WASHTENAW COUNTY ADMINISTRATOR

Supervisor Schwartz explained that the County has been conducting the hiring process for a County Administrator for over a year. Although they have an acting-administrator, he feels that the County needs to have person appointed to the position because there is business that needs to be attended to. He recommends the County appoint Robert Tetens to the position.

The following resolution was moved by Caviston, seconded by Williams:

**SUPERIOR CHARTER TOWNSHIP
WASHTENAW COUNTY, MICHIGAN**

**SUPERIOR CHARTER TOWNSHIP BOARD
REGULAR MEETING
MARCH 21, 2016
PROPOSED MINUTES
PAGE 19**

**A RESOLUTION OF SUPPORT FOR ROBERT TETENS TO BE APPOINTED
WASHTENAW COUNTY ADMINISTRATOR**

WHEREAS, Washtenaw County has been served by several sound county administrators for many years; and,

WHEREAS, the former Washtenaw county administrator, Verna McDaniel, announced her retirement in May of 2105, and retired in January 2016; and,

WHEREAS, Gregory Dill has been appointed interim county administrator pending the appointment of a new county administrator by the Washtenaw County Board of Commissioners; and,

WHEREAS, Washtenaw County Board of Commissioners has been searching for over 10 months for a replacement county administrator; and,

WHEREAS, the candidates have been pared down to two (2) individuals Robert Tetens and Muddasar Tawakkul; and,

WHEREAS, both candidates are outstanding persons with impressive backgrounds; however, the Superior Township Board believes that Robert Tetens deserves the honor of serving as the next county administrator for the following reasons:

1. Robert Tetens is very experienced with the entire spectrum of Washtenaw County affairs.
2. Robert Tetens has a long history of living and working in Washtenaw County.
3. Robert Tetens has been an elected official and understands the demands of elective office.
4. Robert Tetens is enormously respected by a diversity of individuals and organizations within the county and state.
5. Robert Tetens has the judgment, temperament and knowledge to succeed from his first day in office.
6. Robert Tetens has worked with supervisory and union personnel, understands the management/labor issues inherent with the position.
7. Robert Tetens has managed a large portfolio of land and facilities. He has shown special attention to areas in the county in need of county recreational services; and,

**SUPERIOR CHARTER TOWNSHIP BOARD
REGULAR MEETING
MARCH 21, 2016
PROPOSED MINUTES
PAGE 20**

WHEREAS, many important issues are pending between townships, cities, villages and school districts with Washtenaw County which need the attention of a fulltime administrator necessitating an immediate appointment without further delay.

NOW THEREFORE, the Superior Township Board hereby supports the appointment of Robert Tetens as the next Washtenaw County Administrator at the Washtenaw County Board of Commissioners earliest convenience.

The motion was approved by unanimous voice vote. The resolution was adopted.

12. PAYMENT OF BILLS

There were no Bills for Payment. It was moved by Caviston, seconded by Green, that the Record of Disbursements be received.

The motion carried by a unanimous voice vote

13. PLEAS AND PETITION

There were no pleas or petitions.

14. ADJOURNMENT

It was moved by Green, seconded by Lewis, that the meeting be adjourned. The motion carried by a voice vote and the meeting adjourned at 9:20 pm.

Respectfully submitted,

David Phillips, Clerk

Kenneth Schwartz, Supervisor

2016

ANNUAL MEETING
SUPERIOR TOWNSHIP



COMMISSIONERS
DOUGLAS E. FULLER
CHAIR
BARBARA RYAN FULLER
VICE-CHAIR
WILLIAM McFARLANE
MEMBER

WASHTENAW COUNTY
BOARD OF COUNTY ROAD COMMISSIONERS
555 NORTH ZEEB ROAD
ANN ARBOR, MICHIGAN 48103
WWW.WCROADS.ORG

ROY D. TOWNSEND, P.E.
MANAGING DIRECTOR
SHERYL SODERHOLM SIDDALL, P.E.
DIRECTOR OF ENGINEERING
COUNTY HIGHWAY ENGINEER
JAMES D. HARMON, P.E.
DIRECTOR OF OPERATIONS
TELEPHONE (734) 761-1500
FAX (734) 761-3737

Dear Superior Board of Trustees:

We would like to thank all the Townships for last year's support in assisting the Road Commission complete numerous successful road improvement projects. Without your assistance most of the local road improvements would not have been possible. We are also pleased to provide Superior Township Officials with our 2016 Annual Local Road Program. In addition, we have included a few other updates on our activities and major project initiatives in your Township.

Our Annual Meeting Booklet includes cost summaries of 2015 expenditures in your township. Also, to assist townships in determining the level of local road improvements that you are willing to entertain, we have provided the following items.

1. 2016 Local Road Program and Matching Fund Allocations
2. A Summary of 2015 Maintenance and Project Activities
3. Proposed 2016 Local Road Projects and Dust Control Program
4. 2016 Road & Bridge Improvement Projects
5. PA 283 Projects for 2016
6. Michigan's New Road Funding Summary

Please note **May 20** is the commitment due date for this year's 2016 Local Road Program. Your timely response and participation is essential to successfully accomplish this year's program.

We annually look forward to this opportunity to discuss common issues with the Township Officials and your citizens as we seek solutions to the challenges that we face. If you have any immediate concerns related to the attached information, please feel free to contact me at 327-6662 or our Directions of Operations, Jim Harmon at 327-6653.

Very truly yours,

Roy D. Townsend

Roy D. Townsend, P.E.
Managing Director

RDT:amw

WASHTENAW COUNTY ROAD COMMISSION
2016 LOCAL MATCHING PROGRAM

The Washtenaw County Road Commission is anticipating it will receive \$17,900,000 in Michigan Transportation Fund (MTF) revenues for 2015. The Road Commission is anticipating the same amount of MTF revenues for 2016.

The Road Commission has recognized that local road funds are inadequate to maintain the 1,064 centerline miles of local roads in Washtenaw County; the Road Commission has historically transferred funds from the Primary Road Fund to the Local Road Fund, even though this transfer severely limits maintenance activity on our primary road system.

A summary of our 2016 budget as approved by the Board of Road Commissioners at its regular meeting on December 1, 2015 (RC15-469) is provided as follows.

2016 Road Commission Budget

Revenues

Michigan Transportation Fund	\$ 17,900,000
Federal/ State Funds	\$ 13,707,000
Trunkline Maintenance	\$ 2,378,000
Township Contributions	\$ 3,750,500
Other Contributions	\$ 5,216,000
Miscellaneous Income	<u>\$ 1,640,000</u>
Total	\$ 44,592,500

Expenditures

Administration	\$ 1,061,000
Operations	\$ 8,715,000
Engineering	\$ 2,771,000
Non-Departmental	\$ 7,217,000
Debt Service	\$ 1,306,000
Road Improvement Program	<u>\$ 24,989,000</u>
Total	\$ 46,058,000

Matching Funds

The Road Commission has allocated a total of \$500,000 in 2016 for the conventional Local Road Matching Program. This consists of a countywide allocation of \$423,077 for matching programs on local roads in all twenty townships based on the distribution formula used by the Michigan Department of Transportation to allocate local road funds to the 83 counties of Michigan. In addition to this, recognizing the fact that the urban local roads receive a higher allocation of Michigan Transportation Funds, \$76,923 is allocated based on the amount of urban local miles within eligible townships. Ann Arbor, Augusta, Dexter, Lima, Lodi, Northfield, Pittsfield, Salem, Saline, Scio, Superior, Sylvan, Webster, York and Ypsilanti Townships are within the urban area and are eligible for these additional matching funds.

The Road Commission has allocated \$200,000 for the 2016 Drainage Matching Program for local uncurbed, non-subdivision roads. The Road Commission has recognized the need for directing more resources towards improving the drainage along our local roads. The drainage matching program is in addition to the conventional local road matching program available to the Townships. Some of the key features of drainage matching program include:

- Funding distribution is based on the total uncurbed, non-subdivision local road centerline mileage for each township
- Eligible work activities are limited to uncurbed, non-subdivision local roads
- Eligible work activities include roadside berm removal, ditch establishment & restoration, large culvert or bridge replacement

TOWNSHIP	2015 CONVENTIONAL LOCAL ROAD MATCHING PROGRAM	2016 CONVENTIONAL LOCAL ROAD MATCHING PROGRAM	2015 DRAINAGE MATCHING PROGRAM	2016 DRAINAGE MATCHING PROGRAM
Salem	\$ 16,373	\$ 16,425	\$ 10,493	\$ 10,493
Northfield	24,916	25,002	13,732	13,732
Webster	17,714	17,770	11,792	11,792
Dexter	15,974	16,023	6,932	6,932
Lyndon	11,956	11,995	10,048	10,048
Sylvan	13,731	13,443	11,489	11,489
Lima	15,393	15,447	12,745	12,745
Scio	37,857	37,425	7,157	7,157
Ann Arbor	10,759	10,580	3,833	3,833
Superior	31,537	31,412	8,793	8,793
Ypsilanti	104,199	104,177	5,924	5,924
Pittsfield	68,504	68,741	4,669	4,669
Lodi	22,538	22,623	12,879	12,879
Freedom	13,526	13,575	13,684	13,684
Sharon	10,406	10,442	9,971	9,971
Manchester	14,268	14,316	13,176	13,176
Bridgewater	11,725	11,765	11,481	11,481
Saline	9,471	9,504	8,125	8,125
York	27,101	27,206	8,521	8,521
Augusta	22,054	22,127	14,554	14,554
	\$ 500,000	\$ 500,000	\$ 200,000	\$ 200,000

*Totals do not equal sum of individual allocations, because of rounding

The WCRC Matching Program is subject to the following conditions:

a) Township Assistance

In order to allow local road improvements to proceed in a timely manner, townships are asked to assist Road Commission personnel in acquiring necessary tree removal and grading permits, holding public hearings and coordinating any necessary citizen contacts.

b) (b) Project Overruns

Road Commission staff will provide an estimated cost for each individual project to be included within the agreement between the township and the Road Commission. If, prior to beginning an individual project, it is determined that the original cost estimate will not cover project costs, the Road Commission will notify the township to determine, if the township desires to proceed with the project with a reduced scope or an additional funding commitment. Budgets are closely monitored on each project and every effort is made to avoid overruns. Any unexpected project cost overrun shall be taken from any

projects will be shared equally with the townships. Available local matching funds can be utilized to cover 50% the townships share of a local road bridge project costs.

h) Shoulder Paving

If a local road is to be paved, the Road Commission will pay the cost of paving the shoulders when it is feasible. The Road Commission has agreed to assume this cost because of the enhanced safety for vehicles and non-motorized travel and reduced maintenance costs inherent in paved shoulders. This provision will not apply to subdivision streets.

i) Dust Control

Conventional matching funds can be used for dust control only for solid applications.

j) Local Matching Fund Carryover

If a township determines that they desire to carry over the funds allocated for a given year into the following year, the township must provide written notification to the Road Commission that they are requesting this carryover, and identify an eligible project for which the funds will be held. The Road Commission carry-over fund will be preserved for one year. Beyond this point the funds will be reallocated as stated in Paragraph f. The carryover option allows the township to accumulate the funds that are allocated with the previous year allocation; in other words, the carry over funds cannot exceed the previous year's allocation.

SUPERIOR TOWNSHIP 2015 ACTIVITIES

LOCATION	PROJECT	WCRC COST	TOWNSHIP COST	TOTAL COST
PRIMARY				
Maintenance	Roads	\$ 159,545.69		\$ 159,545.69
Maintenance	Winter	126,883.20		126,883.20
Maintenance	Traffic	36,151.63		36,151.63
* MacArthur (btwn Clark & Harris)	HMA Resurfacing	187,272.21		187,272.21
* Superior Rd (btwn HRD & Geddes)	HMA Resurfacing	273,463.57		273,463.57
* Curtis Rd	HMA Wedging/Double Chipseal	61,106.66		61,106.66
^ Plymouth Rd at Curtis Rd	Intersection Improvements	275,177.00		275,177.00
^ Plymouth Rd at Ford Rd	Traffic Signal	615,756.19		615,756.19
* Harris Rd	HMA Resurfacing	68,414.97		68,414.91
		\$ 1,803,771.12	\$ -	\$ 1,803,771.06

LOCAL				
Maintenance	Roads	\$ 132,221.35		\$ 132,221.35
Maintenance	Winter	53,388.76		53,388.76
Maintenance	Traffic	8,334.12		8,334.12
Local Road	Dust Control	43,739.04	12,078.20	55,817.24
Short St	HMA Resurfacing	1,941.65	13,382.38	15,324.03
Church St	HMA Resurfacing	7,987.79	55,053.95	63,041.74
Stamford Rd	HMA Resurfacing	9,625.89	66,344.19	75,970.08
Township Wide Limestone	Limestone	6,656.79	45,880.34	52,537.13
Gale Rd	Limestone	959.29	6,611.71	7,571.00
Hickman Rd	Drainage	1,080.39	7,446.31	8,526.70
Vorhies Rd	Crossroad Culvert	3,378.28	-	3,378.28
		\$ 269,313.35	\$ 206,797.08	\$ 476,110.43

* PA 283 Project
 ^ Federal Aid

SUPERIOR TOWNSHIP

PROPOSED 2016 LOCAL ROAD PROJECTS

- JOY ROAD, CURTIS ROAD TO GOTFREDSON ROAD
Work to include ditching, roadside berm removal, tree trimming, shaping the existing surface, the placement of a 6" (C.I.P.) 23a limestone (approximately 5,300 tons) with associated dust control and project restoration. Proposed township share project with Salem Township.
Estimated project cost \$ 165,000
Estimated project cost to Superior Township: \$ 82,500

- JOY ROAD, GOTFREDSON ROAD TO PLYMOUTH ROAD
Work to include ditching, roadside berm removal, tree trimming, shaping the existing surface, the placement of a 6" (C.I.P.) 23a limestone (approximately 2,600 tons) with associated dust control and project restoration. Proposed township share project with Salem Township.
Estimated project cost \$ 89,200
Estimated project cost to Superior Township: \$ 44,600

- TOWNSHIP WIDE LIMESTONE
Work to include the application of a 23a limestone surface with associated dust control on various local roads within the township. Locations to be determined by the Township Supervisor and District Foreman. Estimated cost of \$17.37 per ton includes all labor, equipment and material costs.
The township can establish a "not to exceed" cost.

- WINDSOR COURT
Work to include, pulverizing the existing surface, the placement of a 3.5" HMA overlay and associated project restoration.
Estimated project cost: \$ 30,200

- OXFORD COURT
Work to include, pulverizing the existing surface, the placement of a 3.5" HMA overlay and associated project restoration.
Estimated project cost: \$ 29,600

- PANAMA STREET
Work to include, pulverizing the existing surface, the placement of a 3.5" HMA overlay and associated project restoration.
Estimated project cost: \$ 107,400

- CHURCH STREET
Work to include, pulverizing the existing surface, the placement of a 3.5" HMA overlay and associated project restoration.
Estimated project cost: \$ 54,300

- ASHTON COURT
Work to include, pulverizing the existing surface, the placement of a 3.5" HMA overlay and associated project restoration.
Estimated project cost: \$ 27,600

WASHTENAW COUNTY ROAD COMMISSION

2016 DUST CONTROL

<u>MATERIAL</u>	<u>COST/GALLON APPLIED</u>
Contract Brine	\$0.1575

SUPERIOR TOWNSHIP

31.74 miles certified local gravel roads

Contract Brine

(Recommended application rate – 2,000 gallons per mile)

Three Solid Applications 190,440 gallons = \$ 29,994.30

For Information Only

2015 Use: 184,400 gallons Contract Brine
(3 solid applications)

- LEGEND
- COUNTY LINE
 - CORPORATE LIMITS
 - STATE TRUNKLINE
 - COUNTY PRIMARY
 - COUNTY LOCAL
 - ADJACENT COUNTY
 - CITY OR VILLAGE
 - STREET

PRIMARY ROAD SYSTEM IS 31.86 MILES
 LOCAL ROAD SYSTEM IS 35.87 MILES

I HEREBY CERTIFY THAT THE ROADS SHOWN HEREIN BY SYMBOL OR IN RED AS PRIMARY ROADS AND THOSE SHOWN HEREIN BY SYMBOL OR IN GREEN AS LOCAL ROADS ARE IN USE AND ARE UNDER THE JURISDICTION OF THE COUNTY ROAD COMMISSION.

CHAIRMAN _____ DATE _____

SUPERIOR

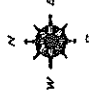

SCALE 0 1/2 1 MILE
 One Inch Equals 3000 Ft.

Prepared by

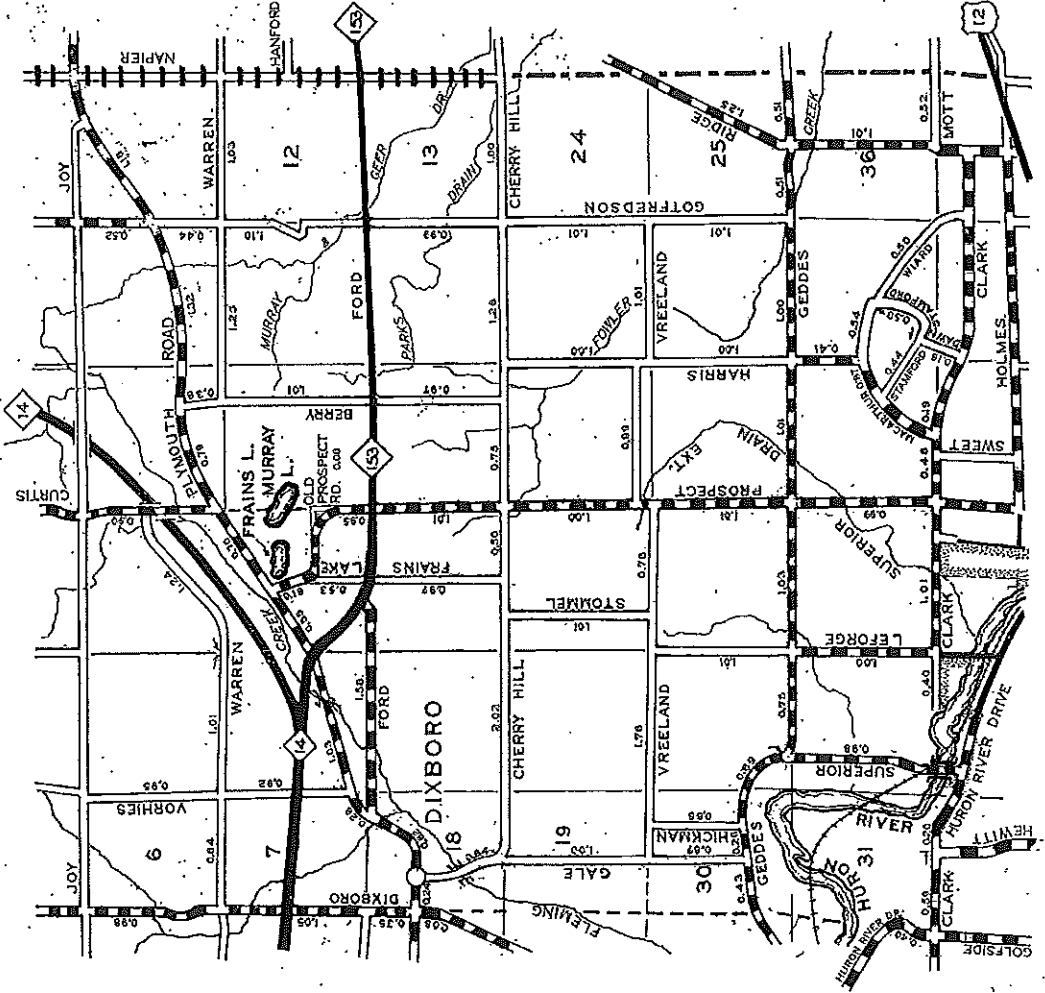

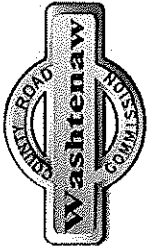

Federal Aid Eligible Paved Roads

2014 Pavement Surface Evaluations and Ratings (PASER)

- 10 - New construction
- 9 - Like new condition, recent overlay, no defects.
- 8 - Occasional transverse crack, at crack light.
- 7 - First signs of aging. Transverse cracks 10-40' long, no rutting or raveling. Few, if any patches.
- 6 - Shows signs of aging, sound structural condition. First signs of blebs, cracking, slight raveling, patching, rutting. No rutting.
- 5 - Surface aging, sound structural condition. Shows signs of aging or cracking at top. Some patching and rutting. Moderate rutting.
- 4 - Concrete slabbed first signs of need for resurfacing. Longitudinal cracking in wheelpath. Rutting 1/2" - 1" deep. Patching in air condition.
- 3 - 1/2" deep alligator cracking. Moderate rutting. Occasional potholes. Cracks allowing erosion.
- 2 - Severe deterioration. 25% alligator cracking. Severe rutting. Potholes frequent.
- 1 - Loss of surface integrity. Extensive surface distress.

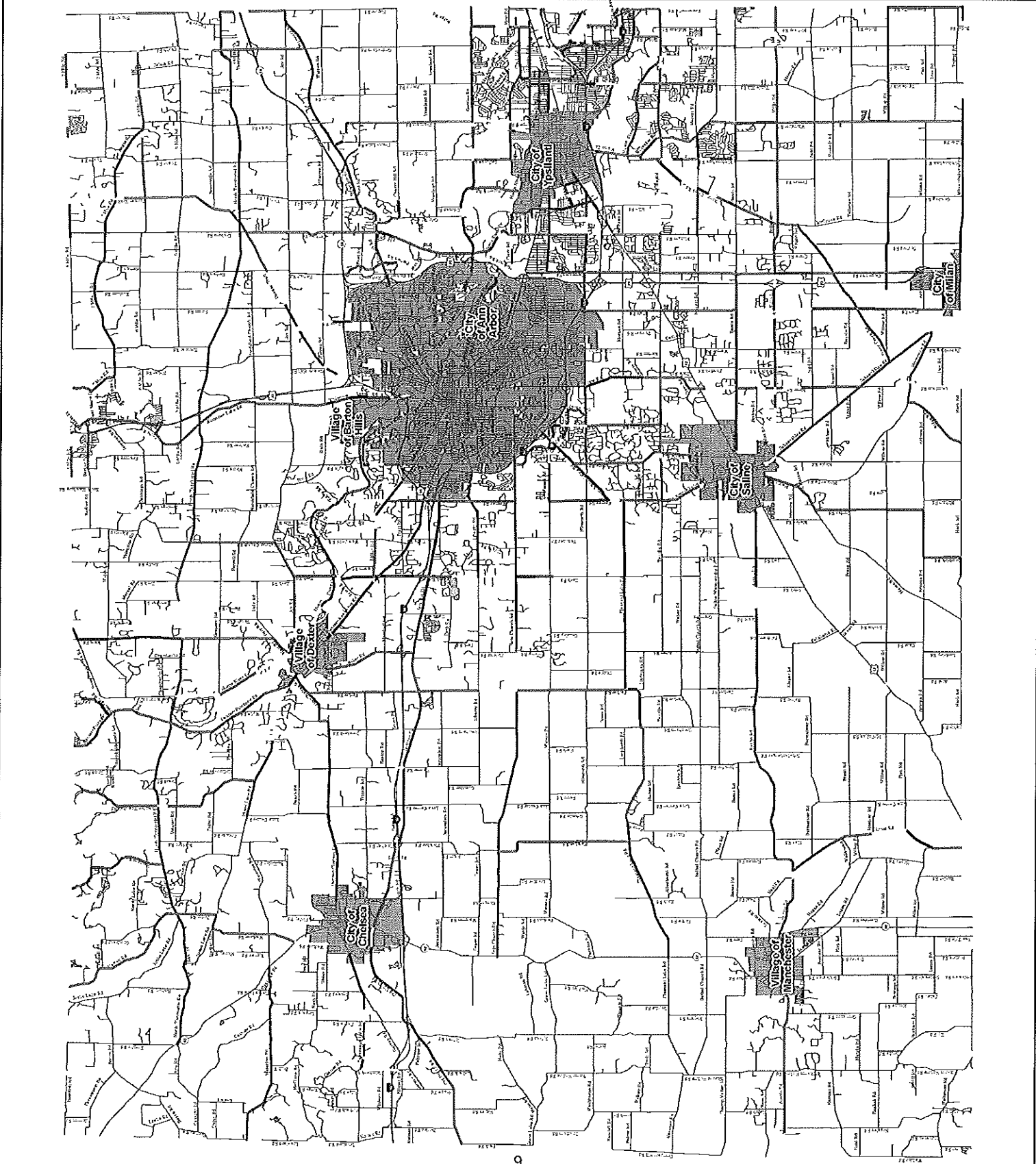

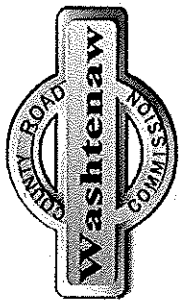

**Federal Aid
Eligible Paved Roads**

**2014 Pavement Surface
Evaluations and Ratings
(PASER)**

- Crack Seal - Rating 6-10
- Sealcoat - Rating 5
- Overlay - Rating 4
- Mill/Overlay - Rating 3
- Reconstruct - Rating 1-2

Superior Township

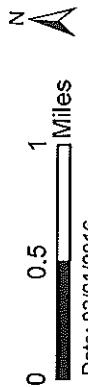

Date: 03/01/2016

Note: 2014 PASER Ratings

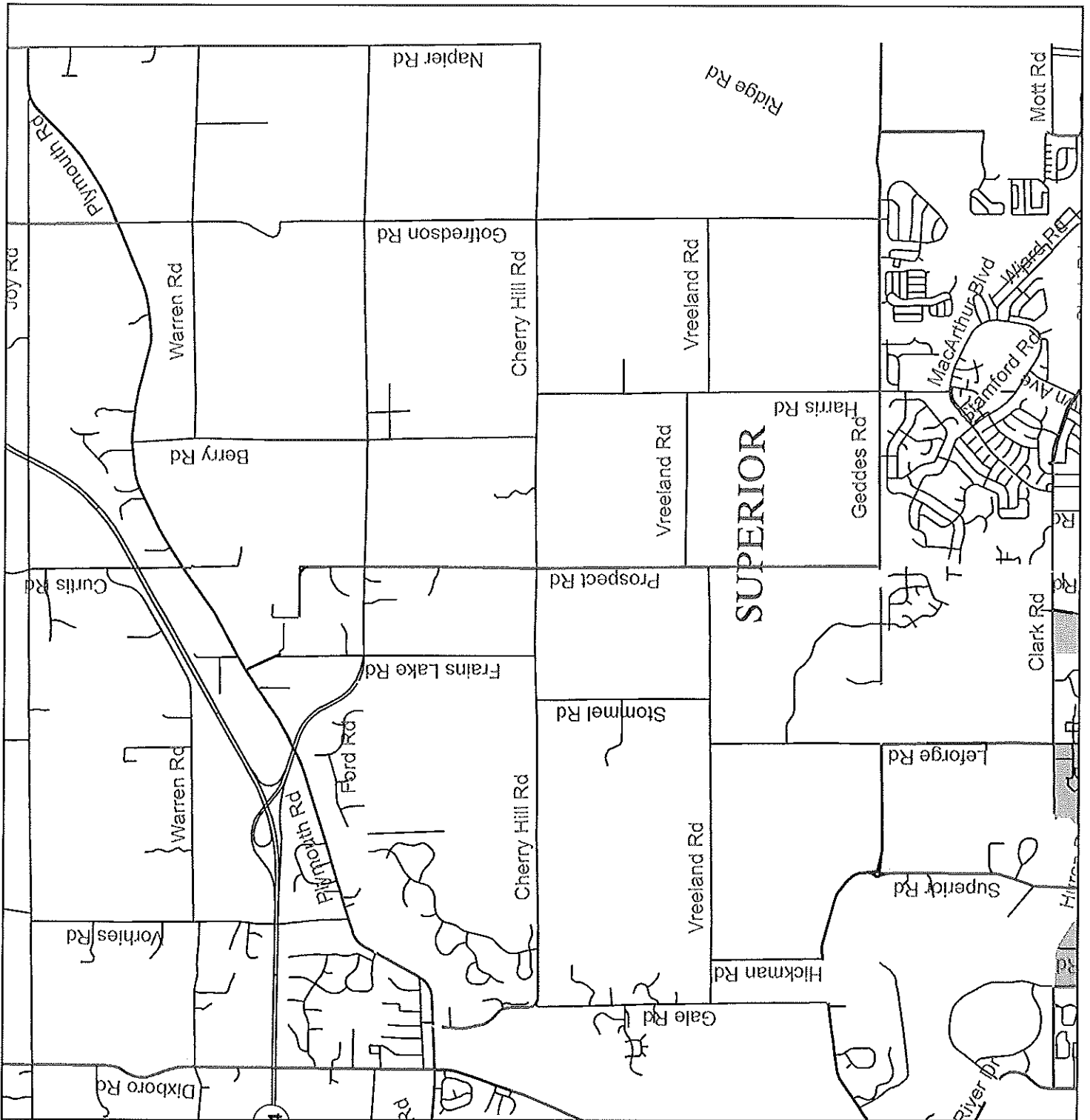

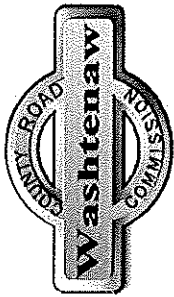

**2015 PASER Ratings
Paved Local Roads &
Non-Federal Aid Roads**

**2015 Pavement Surface
Evaluations and Ratings
(PASER)**

- Crack Seal - Rating 6 -10 10.36 miles
- Sealcoat - Rating 5 3.25 miles
- Overlay - Rating 4 3.52 miles
- Mill/Overlay - Rating 3 6.29 miles
- Reconstruct - Rating 1-2 6.36 miles

Superior Township

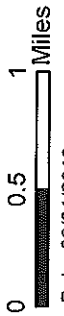

Date: 03/01/2016

Note: 2015 PASER Ratings

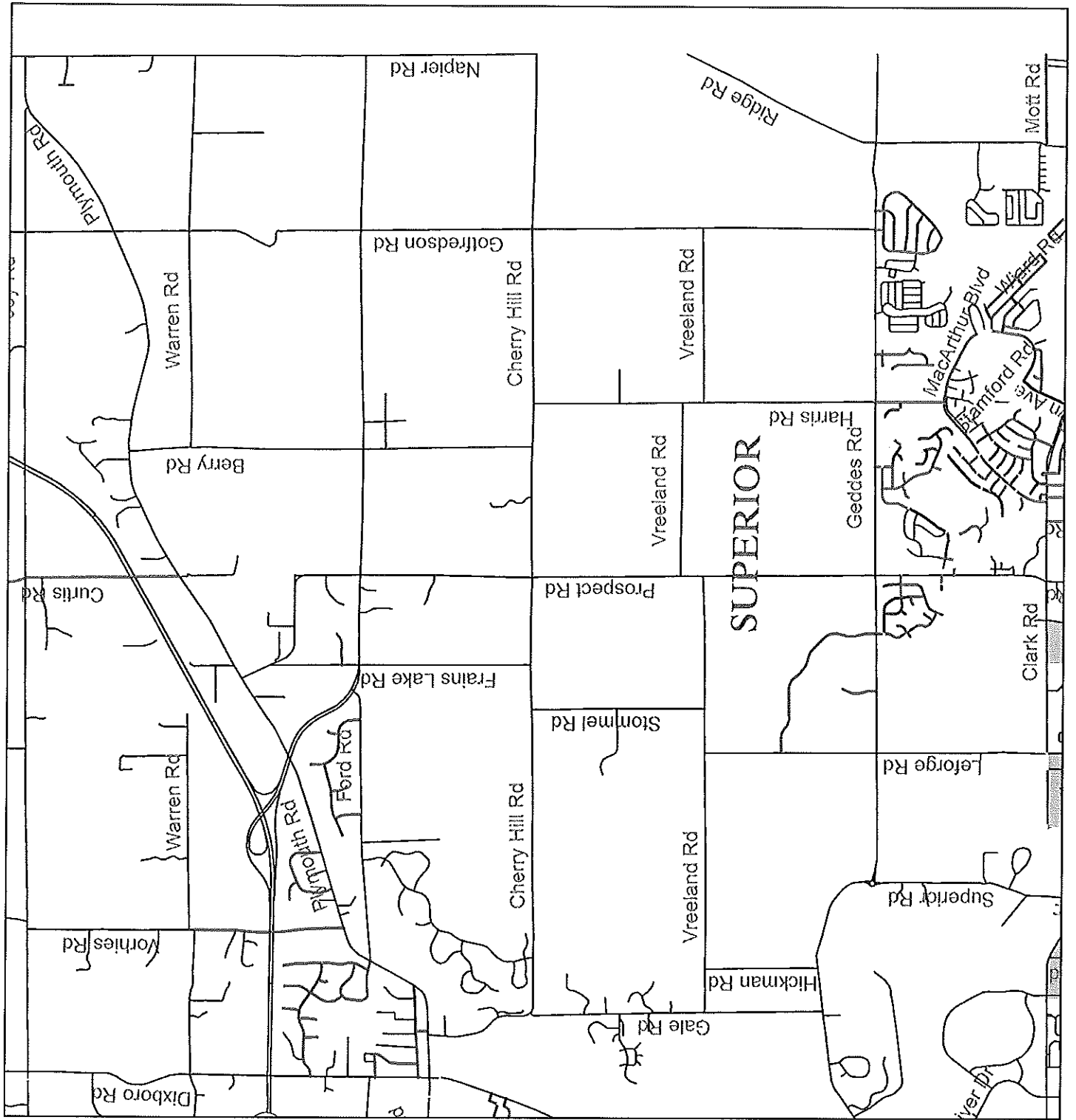

Planned Capital Investments - Michigan Transportation Fund Obligations

Project Name	Planning Area	Project Limits	Project Type	Year	Total MTF Cost (1,000's)	Total Project Cost (1,000's)
Asset Mgmt/GIS	WCRC	Countywide	GIS/Mapping	2016-2020	\$50	\$50
Diesel Retrofit	WCRC	Countywide	Equipment	2016	\$600	\$1,000
Equipment/Fleet	WCRC	Countywide	Equipment	2016-2020	\$1,625	\$1,625
Facility and Grounds	WCRC Property	Countywide	Facility & Grounds	2016-2020	\$375	\$375
Northeast Service Center	WCRC Property	Northeast Service Center	Site Civil Design	2016	\$100	\$100
Overlay Program	Countywide	Countywide	Resurface	2016-2020	\$0	\$0
Primary Limestone/Gravel	Countywide	Countywide	Resurface	2016-2020	\$500	\$500
Sealcoat Program	Countywide	Countywide	Resurface	2016-2020	\$1,500	\$1,500
Traffic Calming Program	Countywide	Countywide	Safety	2016-2020	\$0	\$500
Local Bridge Program	Countywide	Countywide	Bridge	2016-2020	\$500	\$1,250
Primary Bridge Program	Countywide	Countywide	Bridge	2016-2020	\$1,600	\$1,600
Jerusalem Road Bridge	Lima	Over Mill Creek	Bridge - Preserve Deck	2016	\$31	\$174
Maple Road Bridge	Saline/York	Over Saline River	Bridge - Preserve Deck	2016	\$25	\$144
McGregor Road Bridge	Dexter	Over Portage Lake Outlet	Bridge - Replace	2016	\$359	\$2,060
Mooreville Road Bridge	York	Over Saline River	Bridge - Preserve Deck	2016	\$33	\$190
Ward Road Bridge	Ypsilanti	Over Tyler Road	Bridge Removal	2016	\$263	\$1,512
Huron River Drive Bridge	Ann Arbor	Over Pittsfield-Ann Arbor Drain	Bridge - Preserve Deck	2017	\$60	\$250
Ridge Road Bridge	York	Over Macon Creek	Bridge - Replace	2017	\$252	\$1,050
Shield Road Bridge	Scio	Over Mill Creek	Bridge - Replace	2017	\$466	\$1,938
Superior Road Bridge	Superior	Over Huron River	Bridge - Preserve Deck	2017	\$127	\$531
Limestone Program - PA 283	Countywide	Countywide	Resurface	2016	\$0	\$0
HMA Resurfacing Program - PA 283	Countywide	Countywide	Resurface	2016	\$0	\$2,950
Sealcoat Program - PA 283	Countywide	Countywide	Resurface	2016	\$0	\$1,300
Pavement Preservation STL	Countywide	Countywide	Resurface	2016-2020	\$346	\$1,727
Pavement Preservation STU	Countywide	Countywide	Resurface	2016-2020	\$612	\$3,062
Pavement Preservation TEDF-D	Countywide	Countywide	Resurface	2016-2020	\$165	\$833
Resurfacing 3R STL	Countywide	Countywide	Resurface	2016-2020	\$313	\$1,565
Resurfacing 3R STU	Countywide	Countywide	Resurface	2016-2020	\$787	\$3,939
Resurfacing 3R TEDF-D	Countywide	Countywide	Resurface	2016-2020	\$224	\$1,115
Ann Arbor-Saline Road	Lodi	At Textile Road	Safety - Intersection	2016	\$125	\$625
Guardrail Upgrades	Countywide	Countywide	Safety - Roadside	2016	\$95	\$264
Huron Road/Whittaker Road	Ypsilanti	Stony Creek Road to I-94	Resurface	2016	\$125	\$625
Liberty Road	Scio	Park Road to Stag's Leap Lane	Drainage, Limestone	2016	\$0	\$600
Plymouth Road	Ann Arbor/Superior	Earhart Road to Ford Road	Traffic Signal Interconnect	2016	\$25	\$300
Prospect Road	Superior/Ypsilanti	Holmes Road to Geddes Road	Resurface	2016	\$50	\$250
Rawsonville Road	Augusta	Willow Road to Talladay Road	Resurface	2016	\$0	\$625
Scio Township SAD	Scio	Various Roads in Scio Township	Resurface	2016	\$0	\$600
Textile Road	Lodi	Ann Arbor-Saline Road to Maple Rd	Resurface	2016	\$100	\$500
Traffic Signal Backplate Installation	Countywide	Countywide	Safety - Intersection	2016	\$67	\$278
Whittaker Road	Ypsilanti	At Merrill Road	Safety - Roundabout	2016	\$232	\$982
Willis Road	Augusta	Hitchingham Road to Whittaker Road	Safety	2016	\$264	\$1,244
Carpenter Road	York/Pittsfield	Judd Road to Textile Road	Resurface	2017	\$125	\$625
Harris Road	Ypsilanti	Michigan Avenue to Holmes Road	Reconstruct	2017	\$513	\$1,925
Rawsonville Road	Augusta	Talladay Road to Judd Road	Resurface	2017	\$0	\$400
Scio Church Road	Scio/Lodi	At Wagner Road	Congestion - Roundabout	2017	\$397	\$960
STL	TBD	TBD	TBD	2018	\$0	\$0
STU	TBD	TBD	TBD	2018	\$125	\$625
TEDF-D	TBD	TBD	TBD	2018	\$0	\$0
STL	TBD	TBD	TBD	2019	\$0	\$0
STU	TBD	TBD	TBD	2019	\$250	\$1,250
TEDF-D	TBD	TBD	TBD	2019	\$0	\$0
STL	TBD	TBD	TBD	2020	\$0	\$0
STU	TBD	TBD	TBD	2020	\$250	\$1,250
TEDF-D	TBD	TBD	TBD	2020	\$0	\$0
				Totals	\$13,656	\$46,768

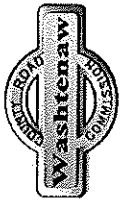

Washtenaw County Projects 2015 - 2016

Projects
 Road Commission
 & Federal Funds

2015 ———

2016 ———

PA283 ———

2015 ———

2016 ———

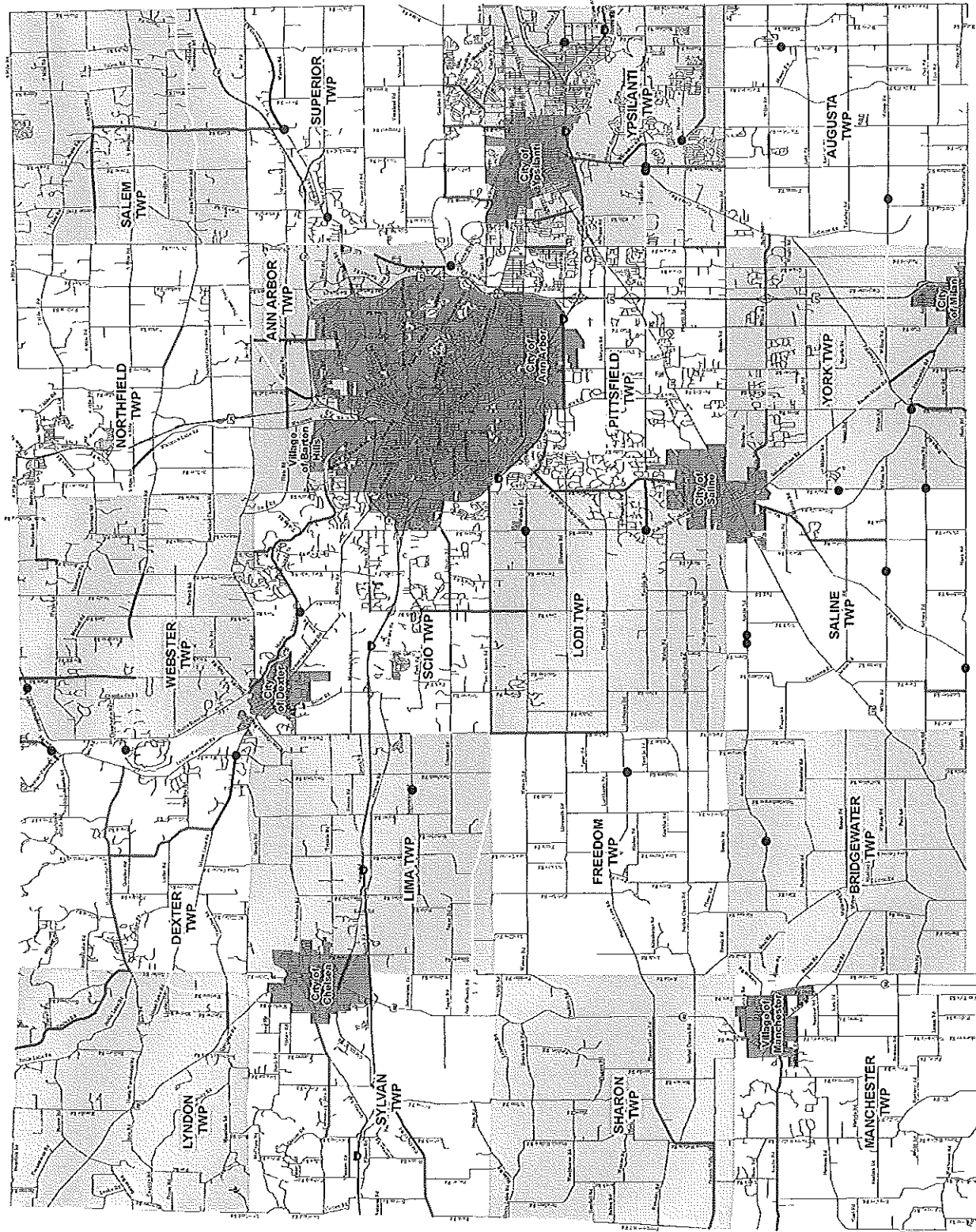
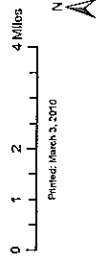

Road	WCC Dist	Note	Project Limits	Type of Work	Length	Est. Cost	Est. Cost-0.5
Parker Road	1		Jerusalem to Liberty	Pulverize and Overlay	1.0	\$ 300,000	
Werkner, Isl Lk, Stofer	1		M-52 to North Territorial	Chipseal	3.5	\$ 90,000	
North Territorial Road	1		Dexter-Pinckney to Huron River Drive	Chipseal	1.0	\$ 25,000	
Zeeb Road	1		Huron River Drive to Joy	Mill and Overlay	1.1	\$ 180,000	
Zeeb Road	1		Pratt to Huron River Drive	Chipseal	2.0	\$ 50,000	
Scio Church Road	1	A-2	Parker to 0.7-mile west of Steinbach	Chipseal	1.7	\$ 20,000	
Scio Church Road	1		M-52 to 0.7-mile west of Steinbach	Chipseal	5.5	\$ 120,000	
Dexter Ann Arbor	1		Zeeb to M 14	Chipseal & Fog Seal	2.8	\$ 90,000	
Wagner	1		Miller to Huron River Drive	Wedge & Chipseal	1.00	\$ 40,000	\$ 915,000.00
					19.55		
Pontiac Trail	2		Warren to Nixon	Spot Mill & Fill w/ Chipseal	1.5	\$ 130,000	
North Territorial Road	2		Tower to Napier	Chipseal	4.5	\$ 110,000	
North Territorial Road	2		Huron River Drive to Donovan	Chipseal	2.5	\$ 70,000	
Pontiac Trail	2		Sutton to Dixboro	Wedge & Chipseal	2.8	\$ 112,000	
Prospect Road	2		M-153 to Geddes	Chipseal	3.0	\$ 75,000	
Prospect Road	2		Geddes to Clark	Mill & Overlay	1.0	\$ 150,000	
Dixboro Road	2		Geddes to Warren	Chipseal	4.0	\$ 100,000	
Six Mile	2		Currie to Chubb	Pulverize and Overlay	1.00	\$ 300,000	\$ 1,047,000.00
					20.30		
Austin Road	3		M-52 to Clinton	Mill & Overlay	1.7	\$ 270,000	
Willow Road	3		Platt to 1/2 mile east of Sanford	Chipseal	2.0	\$ 50,000	
Scio Church Road	3	A-2	Parker to 0.7-mile west of Steinbach	Chipseal	0.0	\$ 20,000	
Saline-Milan Road	3		Stony Creek to Moon	Mill & Overlay	1.0	\$ 150,000	
Willis Road	3		Moon to Warner	Pulverize and Overlay	1.0	\$ 300,000	\$ 790,000.00
					5.70		
Waters Road	4		Oak Valley to Ann Arbor-Saline	Mill & Overlay	0.5	\$ 150,000	
Platt Road	4		Ellsworth to US 12	Chipseal	2.0	\$ 75,000	
Moon Road	4		US-12 to Bemis	Pulverize & Overlay	1.0	\$ 300,000	
Lohr Road	4		Ellsworth to Textile	Chipseal	2.0	\$ 50,000	
Lohr Road	4		Ellsworth to Ann Arbor-Saline	Mill & Overlay	1.3	\$ 330,000	\$ 905,000.00
					6.80		
Textile Road	5 & 6		Stony Creek to Munger	Mill & Overlay	1.90	\$ 270,000	
Willis Road	5 & 6		Stony Creek to Pitman	Pulverize and Overlay	1.20	\$ 360,000	
Grove Road	5 & 6		Bridge to Rawsonville	Mill & Overlay	0.75	\$ 200,000	\$ 830,000.00
					3.85		
Totals					56.20	\$	\$ 4,487,000

Michigan's New Road Funding Package

What does it mean for Washtenaw County?

On November 10th, 2015, Governor Rick Snyder signed a \$1.2 billion road funding package that will increase the funding provided to the Washtenaw County Road Commission through the Michigan Transportation Fund (MTF). The MTF includes all state-collected road revenue generated from fuel taxes and vehicle registration fees. The MTF is the Road Commission's main source of funding and this is the first increase since 1997.

While additional funding is great news for Washtenaw County's failing road system, the package does not provide any additional road funding in 2016 and residents will not see increases in road improvements until 2017. Read on to learn how this road funding package works, what it will take to fix our road system, and what remains uncertain about the future of state road funding in Washtenaw County.

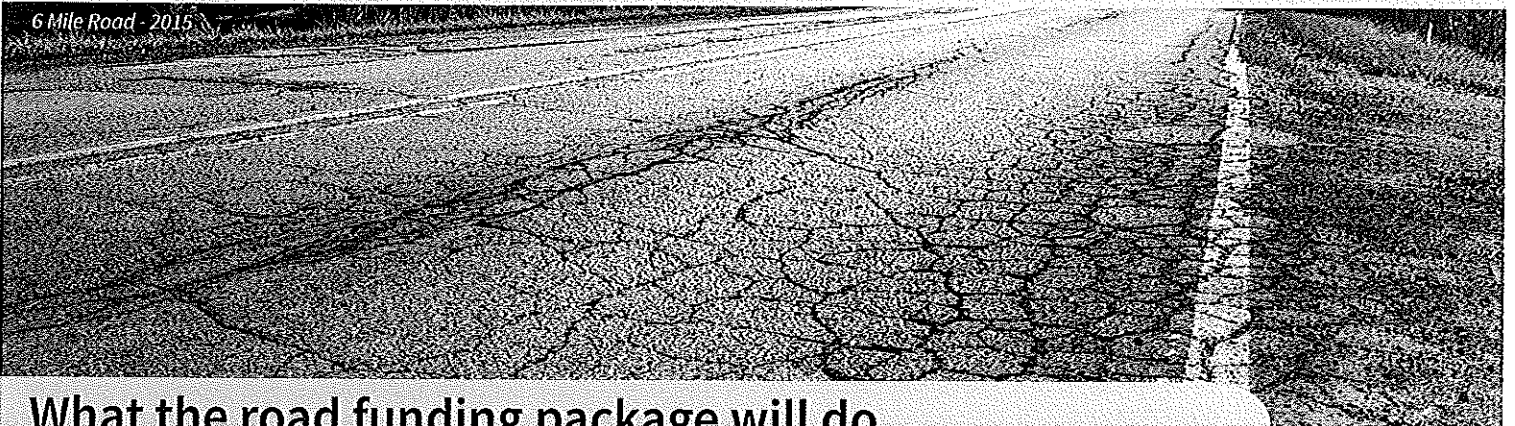

What the road funding package will do

Provides an additional \$1.2B in MTF funding state-wide



The package does not provide full funding until 2021; 6 years from now.

The new funding will begin in 2017



The package provides no funding for road improvements in 2016.

The 1st increase in the MTF since 1997



20 years have passed with no state funding increase and it will take time for WCRC to catch up and fix all the county's "poor" and "failing" roads.

50% of the funding will come from increases in fuel taxes & vehicle registration fees



Beginning in 2017: 20% increase in vehicle registration fees, 7.3¢ increase in the state's gasoline tax, 11.3¢ increase in state's diesel tax.

Beginning in 2018, shifts will be made in the State's General Funds to provide the other 50% of funding.



Lawmakers are relying on continued economic growth to bring in more revenue to the General Fund to fund roads.



How will the new road funding phase in?

The new road funding deal will generate \$1.2 billion by 2021. The first \$600 million will come from vehicle registration and fuel tax increases that start in 2017. The additional \$600 million will be shifted from the state's \$9.9 billion general fund towards roads starting in 2018.

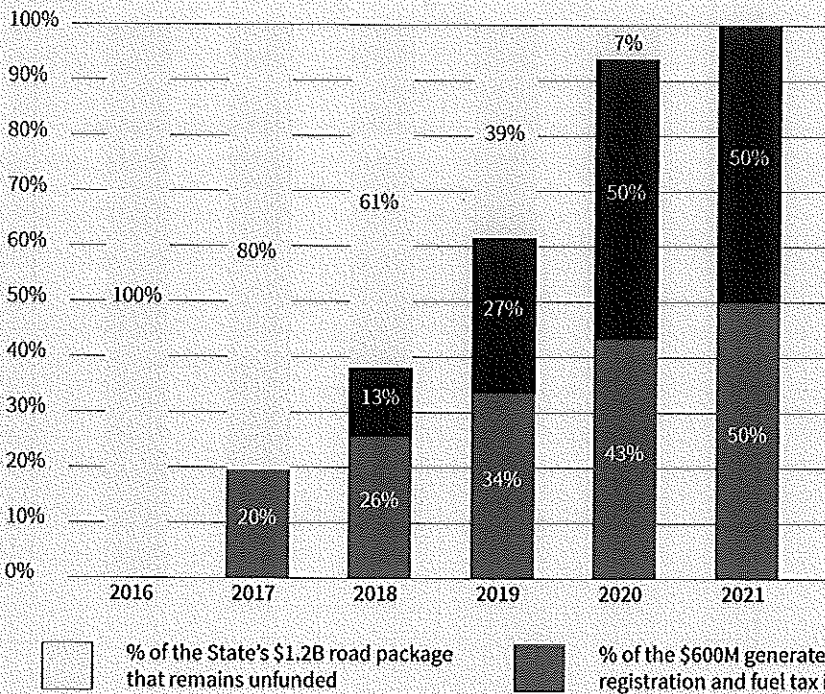

Funding Uncertainty:

The State Legislature did not identify where specifically the \$600 million from the State's General Fund will come from.

Lawmakers are counting on continued economic growth to bring in more tax revenue that could be used for roads. If economic growth does not continue, future legislators may set budget priorities that may or may not fully fund the \$600 million.

How much additional funding will WCRC receive?

In 2014, the Washtenaw County Road Commission received \$17.5 million from the Michigan Transportation Fund (MTF). Estimates predict that the Road Commission will receive an additional \$4.3 million in 2017, \$5.7 million in 2018, \$7.4 million in 2019, \$9.4 million in 2020, and \$12.5 million in 2021 (if the \$600M General Fund dollars are redirected as the law intends).

Will it be enough to fix our failing road system?

Over the past decade, the cost to maintain and repair roads has steadily risen, but the Washtenaw County Road Commission's budget has not kept pace with the rate of inflation. Even if WCRC receives the estimated full amount of funding in 2021 there will be years of catch-up work to be done to fix the county's "poor" and "failing" roads. WCRC estimates that to get all of the county's roads into "good" condition would require over \$50 million. While the new state funding increase will help, it will take five years to phase-in and roads will continue to deteriorate as we await the new funding.

In addition to fixing the county's worst roads, WCRC must also balance the need to preserve the investments that have already been made in the county's "good" roads to increase their lifespans and avoid costly reconstruction projects. WCRC must also factor in the annual cost of winter maintenance, the need for new equipment, and other agency operation costs when determining how to allocate the new road funding from the state.

TOWNSHIP CONTRIBUTION SUMMARY 2011 - 2015

TOWNSHIP	TOTAL 2011	TOTAL 2012	TOTAL 2013	TOTAL 2014	TOTAL 2015	5 Year Average
ANN ARBOR	\$ 49,000	\$ 54,000	\$ 122,000	\$ 224,919	\$ 43,175	\$ 98,618.80
AUGUSTA	\$ 97,000	\$ 202,000	\$ 203,000	\$ 192,169	\$ 158,618	\$ 170,557.40
BRIDGEWATER	\$ 32,000	\$ 34,000	-	\$ 40,306	\$ 54,651	\$ 32,191.40
DEXTER	\$ 90,000	\$ 105,000	\$ 82,000	\$ 536,784	\$ 55,724	\$ 173,901.60
FREEDOM	\$ 42,000	\$ 45,000	\$ 57,000	\$ 31,716	\$ 51,334	\$ 45,410.00
LIMA	\$ 47,000	\$ 51,000	\$ 70,000	\$ 117,285	\$ 118,676	\$ 80,792.20
LODI	\$ 150,000	\$ 415,000	\$ 141,000	\$ 483,502	\$ 67,065	\$ 251,313.40
LYNDON	\$ 20,000	\$ 23,000	\$ 16,000	\$ 45,285	\$ 19,390	\$ 24,735.00
MANCHESTER	\$ 100,000	\$ 128,000	\$ 47,000	\$ 64,246	\$ 77,675	\$ 83,384.20
NORTHFIELD	\$ 42,000	\$ 62,000	\$ 84,000	\$ 93,195	\$ 109,907	\$ 78,220.40
PITTSFIELD	\$ 183,000	\$ 792,000	\$ 393,000	\$ 880,819	\$ 907,340	\$ 631,231.80
SALEM	\$ 173,000	\$ 296,000	\$ 1,042,000	\$ 459,327	\$ 425,626	\$ 479,190.60
SALINE	\$ 101,000	\$ 92,000	\$ 110,000	\$ 143,066	\$ 159,024	\$ 121,018.00
SCIO	\$ 471,000	\$ 1,245,000	\$ 833,000	\$ 1,108,452	\$ 1,269,480	\$ 985,386.40
SHARON	\$ 54,000	\$ 34,000	\$ 20,000	\$ 14,755	\$ 24,306	\$ 29,412.20
SUPERIOR	\$ 161,000	\$ 280,000	\$ 322,000	\$ 324,001	\$ 244,797	\$ 266,359.60
SYLVAN	\$ 17,000	\$ 10,000	\$ 8,000	\$ 26,852	\$ 73,968	\$ 27,164.00
WEBSTER	\$ 135,000	\$ 153,000	\$ 89,000	\$ 16,019	\$ 15,765	\$ 81,756.80
YORK	\$ 26,000	\$ 34,000	\$ 108,000	\$ 418,883	\$ 460,000	\$ 209,376.60
YPSILANTI	\$ 1,190,000	\$ 4,970,000	\$ 2,794,000	\$ 2,510,384	\$ 1,048,026	\$ 2,502,482.00
	\$ 3,180,000	\$ 9,025,000	\$ 6,541,000	\$ 7,731,965	\$ 5,384,547	\$ 6,372,502.40

Five year avg. 2011 - 2015

\$ 6,372,502

2016 Summary of Paved Local and Subdivision Roads Needs for each TOWNSHIP

2016

TOWNSHIP	Crack Seal Road Miles	Crack Seal at \$8k/mi	Surface Treatment Road Miles	Surface Treatment at \$32k/mi	Mill & Overlay Road Miles	Mill & Overlay at \$190k/mi	Pulverization & Pave Road Miles	Pulverization & Pave at \$ 320k/mi	Total Needs for Local & Subd Paved Roads	Average 10 year Expenditure Needs for Paved Roads
ANN ARBOR	0.4	\$ 3,200	0.5	\$ 16,000	2.0	\$ 380,000	2.1	\$ 672,000	\$ 1,071,200	\$ 107,120
AUGUSTA	1.6	\$ 12,800	2.8	\$ 89,600	0.1	\$ 19,000	2.0	\$ 640,000	\$ 761,400	\$ 76,140
BRIDGEWATER	0.0	\$ -	0.0	\$ -	0.0	\$ -	0.5	\$ 160,000	\$ 160,000	\$ 16,000
DEXTER	0.0	\$ -	2.2	\$ 70,400	5.4	\$ 1,026,000	3.0	\$ 960,000	\$ 2,056,400	\$ 205,640
FREEDOM	0.0	\$ -	0.0	\$ -	0.0	\$ -	0.5	\$ 160,000	\$ 160,000	\$ 16,000
LIMA	0.0	\$ -	1.0	\$ 32,000	2.2	\$ 418,000	0.8	\$ 256,000	\$ 706,000	\$ 70,600
LODI	0.2	\$ 1,600	0.0	\$ -	4.2	\$ 798,000	6.7	\$ 2,144,000	\$ 2,943,600	\$ 294,360
LYNDON	0.0	\$ -	0.0	\$ -	0.2	\$ 38,000	0.0	\$ -	\$ 38,000	\$ 3,800
MANCHESTER	0.0	\$ -	0.0	\$ -	0.6	\$ 114,000	0.0	\$ -	\$ 114,000	\$ 11,400
NORTHFIELD	0.0	\$ -	2.1	\$ 67,200	5.0	\$ 950,000	1.8	\$ 576,000	\$ 1,593,200	\$ 159,320
PITTSFIELD	8.4	\$ 67,200	29.5	\$ 944,000	27.6	\$ 5,244,000	5.9	\$ 1,888,000	\$ 8,143,200	\$ 814,320
SALEM	0.9	\$ 7,200	0.3	\$ 9,600	2.4	\$ 456,000	1.0	\$ 320,000	\$ 792,800	\$ 79,280
SALINE	0.0	\$ -	0.0	\$ -	0.6	\$ 114,000	0.7	\$ 224,000	\$ 338,000	\$ 33,800
SCIO	2.6	\$ 20,800	2.5	\$ 80,000	4.9	\$ 931,000	6.2	\$ 1,984,000	\$ 3,015,800	\$ 301,580
SHARON	0.0	\$ -	0.0	\$ -	0.0	\$ -	0.0	\$ -	\$ -	\$ -
SUPERIOR	4.3	\$ 34,400	4.8	\$ 153,600	9.9	\$ 1,881,000	7.2	\$ 2,304,000	\$ 4,373,000	\$ 437,300
SYLVAN	0.8	\$ 6,400	0.6	\$ 19,200	11.1	\$ 2,109,000	2.1	\$ 672,000	\$ 2,806,600	\$ 280,660
WEBSTER	0.2	\$ 1,600	0.0	\$ -	0.8	\$ 152,000	0.4	\$ 128,000	\$ 281,600	\$ 28,160
YORK	2.3	\$ 18,400	7.5	\$ 240,000	7.8	\$ 1,482,000	5.5	\$ 1,760,000	\$ 3,500,400	\$ 350,040
YPSILANTI	13.3	\$ 106,400	59.3	\$ 1,897,600	29.2	\$ 5,548,000	6.3	\$ 2,016,000	\$ 9,568,000	\$ 956,800
TOTALS	35.0	\$ 280,000	113.1	\$ 3,619,200	114.0	\$ 21,660,000	52.7	\$ 16,864,000	\$ 42,423,200	\$ 4,242,320



MAY 2016

SERVICE IMPROVEMENTS

Superior Township

Our Progress So Far

- **May 2014** – Voters approve transportation improvement millage
 - Superior agreement to increase service
- **August 2014** – Phase I of 5YTIP improvements
 - Later weekday and Sat. service by 1 hour on Rt. 10, expanded A-Ride service hours
- **August 2015** – Phase II of 5YTIP service improvements
 - New Sunday service on Rt. 10
 - Saturday service extended (7pm-11pm)
 - Expanded A-Ride Service



Superior Twp. Ridership – Route 10

Superior Township Ridership Route 10
FY 2014 - 2016

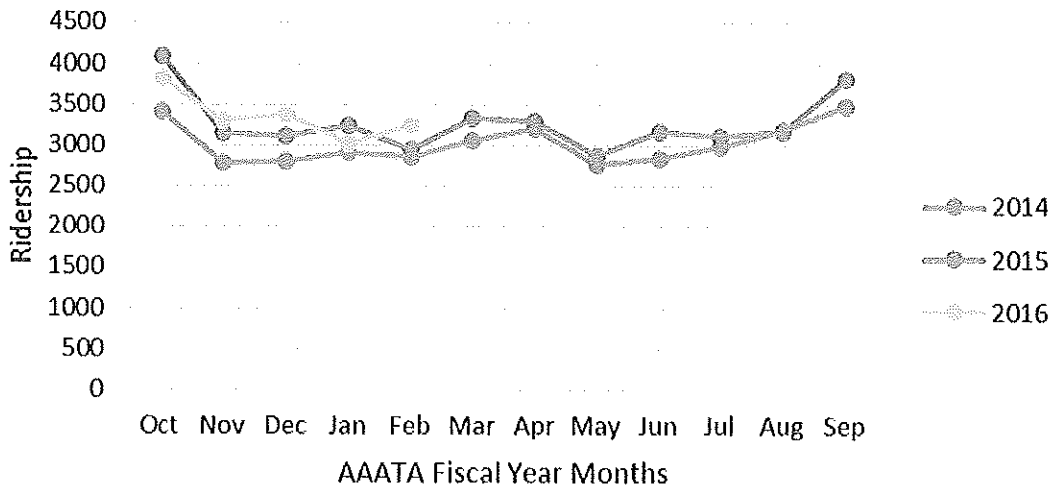

Superior Twp. Ridership - ARide

Superior Township Ridership ARide FY 2014 - 2016

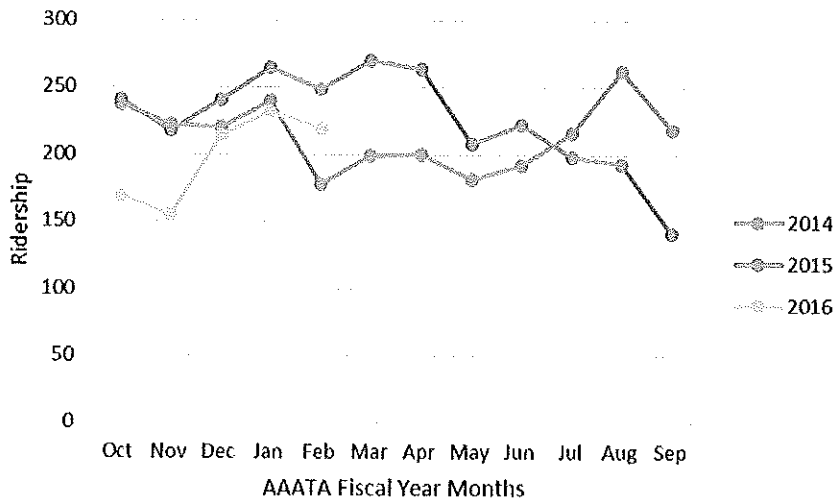

**GET
READY!**

MAY 1ST
Coming Soon!

What's Happening on May 1, 2016?

- Some routes stay the same
- Routes with new numbers and/or names
- New Ann Arbor area routes
- New Ypsilanti area routes
- New service to Scio Twp.
- New service in Pittsfield Twp.

ROUTES WITH SAME NUMBERS / NAMES

- 3 Huron River (see Rt. 3 map later)
- 4 Washtenaw
- 5 Packard
- 6 Ellsworth
- 46 Huron-Textile
- 67 Platt-Michigan Ave

ROUTES WITH NEW NUMBERS OR NAMES

Old Route	New Route	Old Route	New Route
17	21 Amtrak - Depot 	36	62 State – U-M
1	22 Pontiac – Dhu Varren	1U	63 Pontiac – U-M
2	23 Plymouth	14	64 Geddes – E. Stadium 
7	24 S. Main - East 	2C	65 U-M – Downtown – Green
16	25 Ann Arbor – Saline Rd 	22	66 Carpenter – Huron Pkwy
8	28 Pauline	710	91 ExpressRide: Chelsea
13	33 Newport	711	92 ExpressRide: Canton
33	41 EMU COB Shuttle	787	98 AirRide
609	60 Dexter – U-M		

NEW NUMBERING SYSTEM – The method :

Between Ann Arbor & Ypsilanti

Numbered 3 - 6

Ann Arbor Local routes

Numbered 21 - 33

Ypsilanti Local routes

Numbered 41 - 47

Connector/Crosstown Routes

Numbered 60 - 68

Express Routes

Numbered 91 - 98

NEW NUMBERING SYSTEM

Ann Arbor
local routes

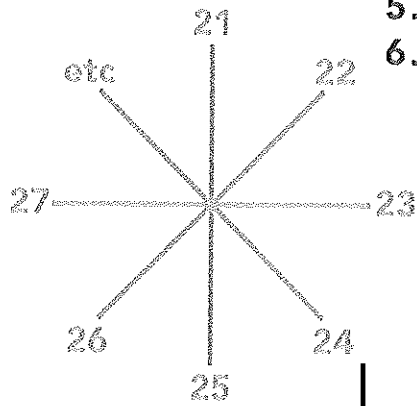

Ann Arbor to Ypsilanti routes



Ypsilanti
local routes

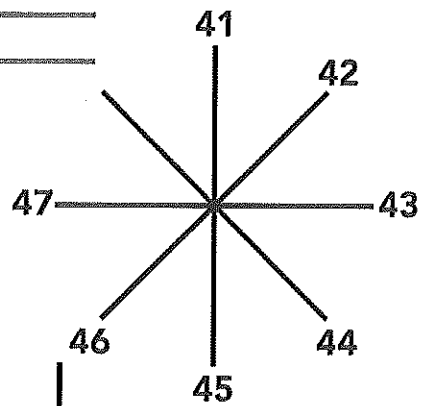

Connector routes



NEW YPSILANTI AREA ROUTES



Ypsilanti Area

Replace routes
10, 11, and 20
with six new routes

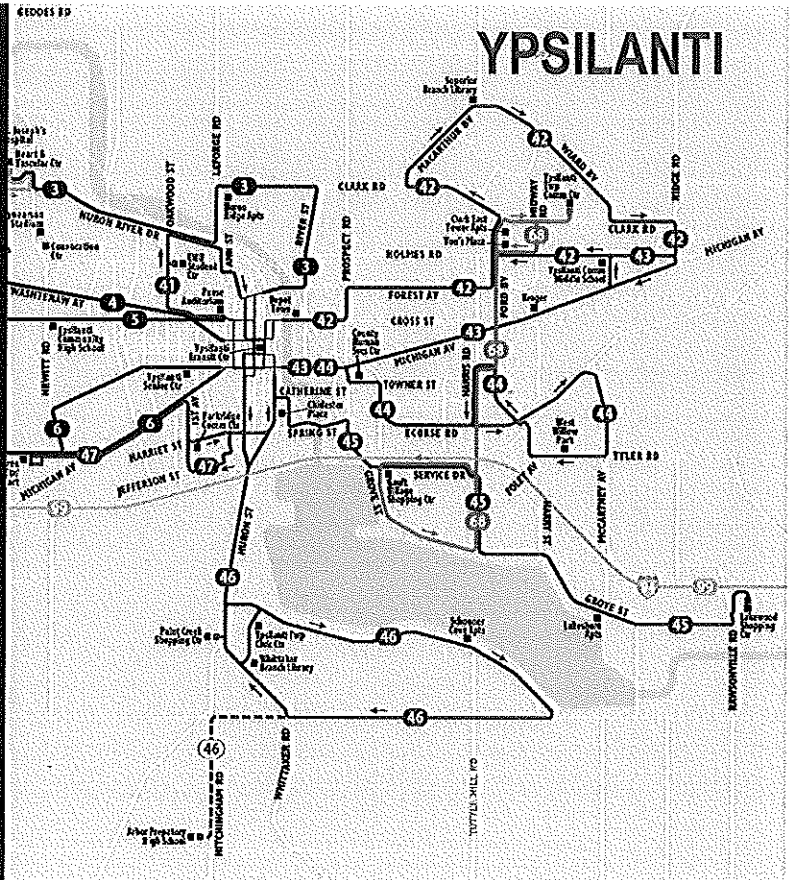

ROUTE

10

Ypsilanti – Northeast

will be replaced by...

42

Forest –
MacArthur

43

E. Michigan Ave

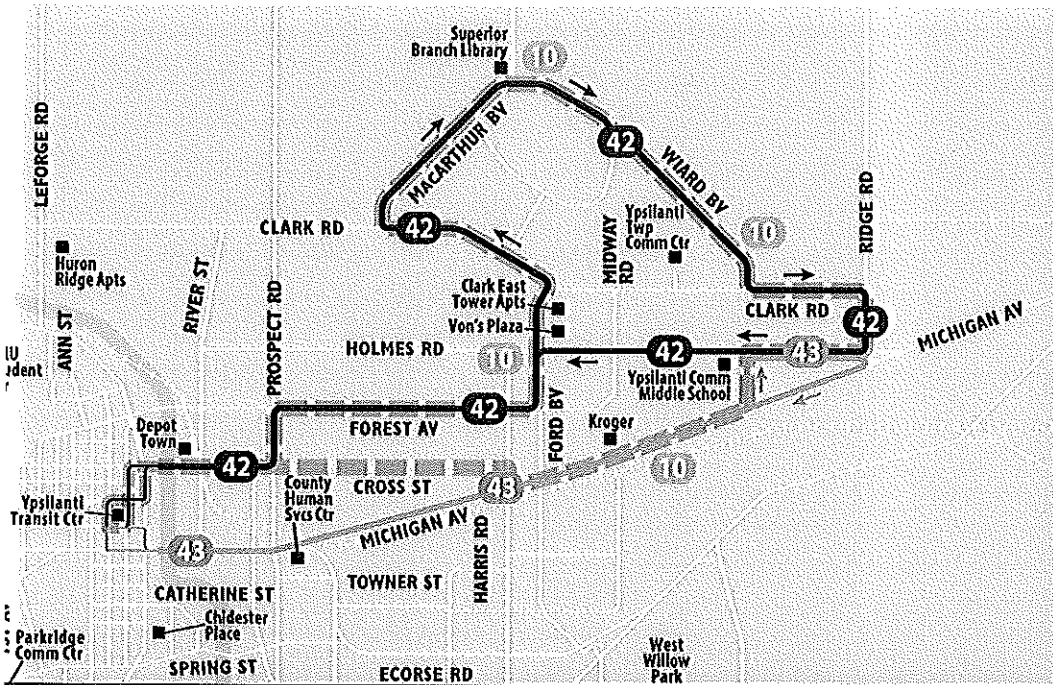

Route 42

- Direct service in both directions on Forest Ave & Cross St; loop route through MacArthur Blvd neighborhood
- Similar to route 10 until Holmes Rd
 - Will no longer serve Michigan Ave or Cross St east of Prospect Rd

Route 43

- Direct service in both directions on Michigan Ave
- Better service to Kroger

YPSILANTI



ROUTE

20

Ypsilanti: Grove -
Ecorse

will be replaced by...

44

Ecorse – Tyler

45

Grove

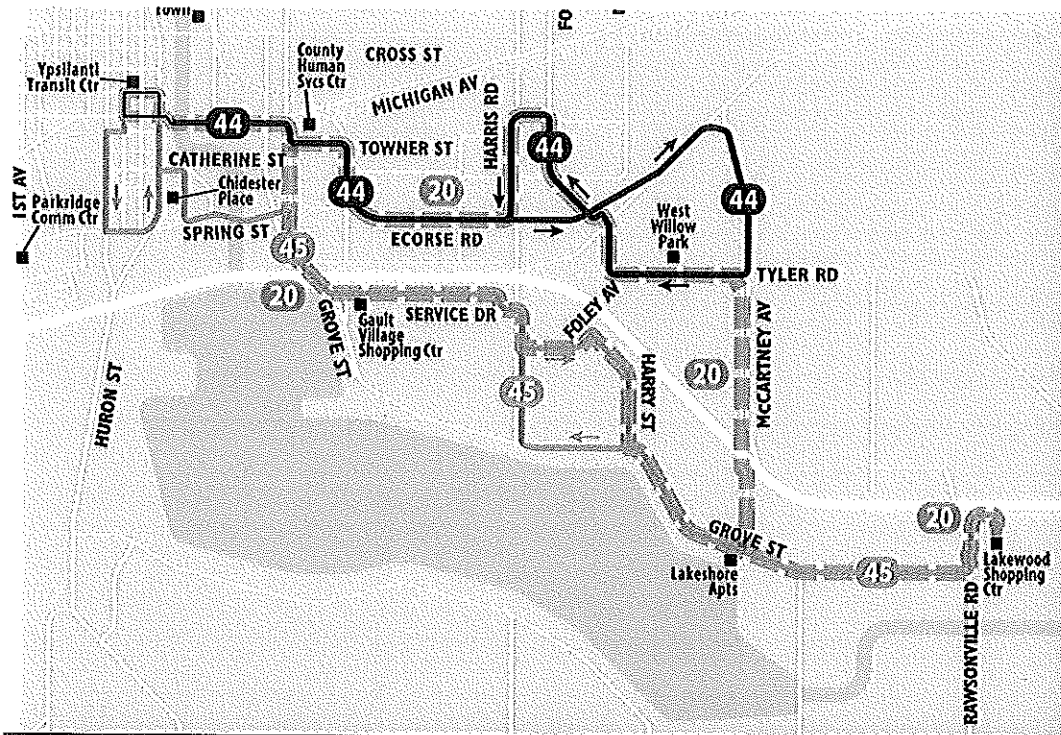

Route 44

- Direct service in both directions on Towner St & Ecorse Rd; loop route through West Willow neighborhood
- Better service to County Human Services Center

Route 45

- Direct service in both directions to Gault Village and on Grove Rd
- Better service to Chidester Place

YPSILANTI



ANN ARBOR AREA TRANSPORTATION AUTHORITY

ROUTE

11

Ypsilanti - South

will be replaced by...

43

E. Michigan Ave

45

Grove

47

Harriet –
W. Michigan Ave

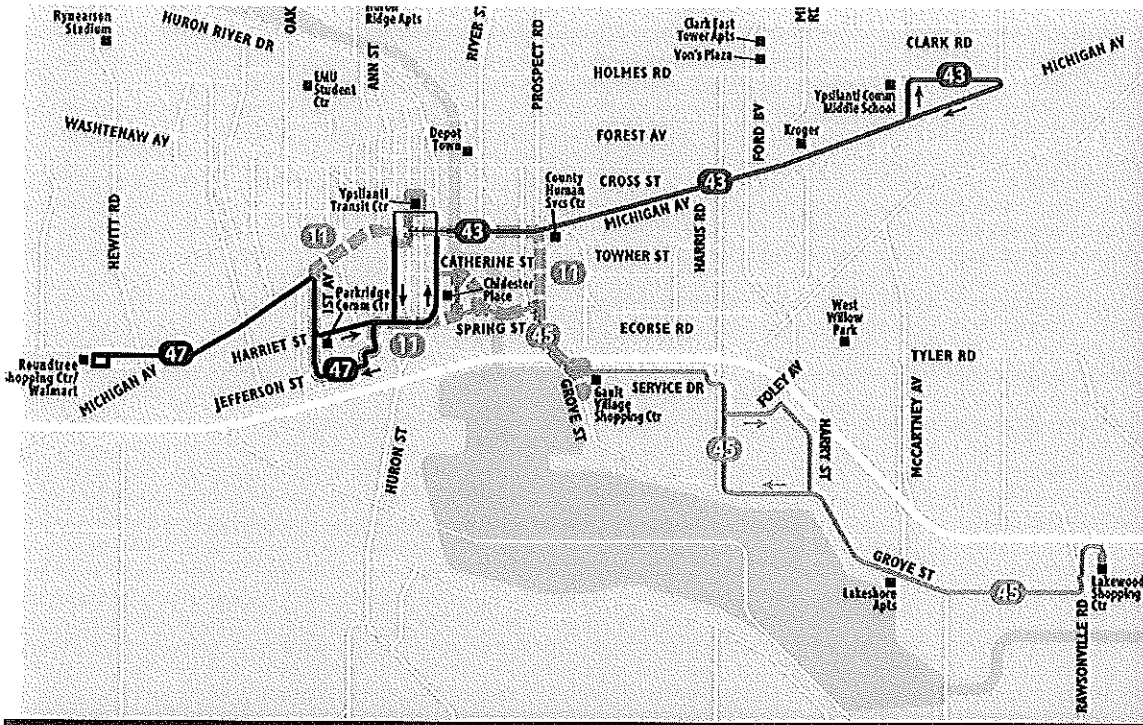

Routes 43 & 45

Route 47

- Connects the southwest neighborhoods of Ypsilanti to downtown and shopping centers in the Michigan Ave/Hewitt Rd area
- Better service to Parkridge Community Center, WalMart

YPSILANTI



68

Harris – Ford

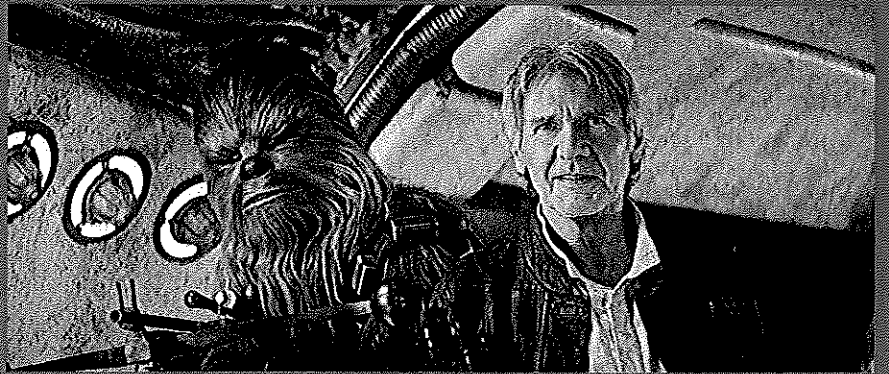

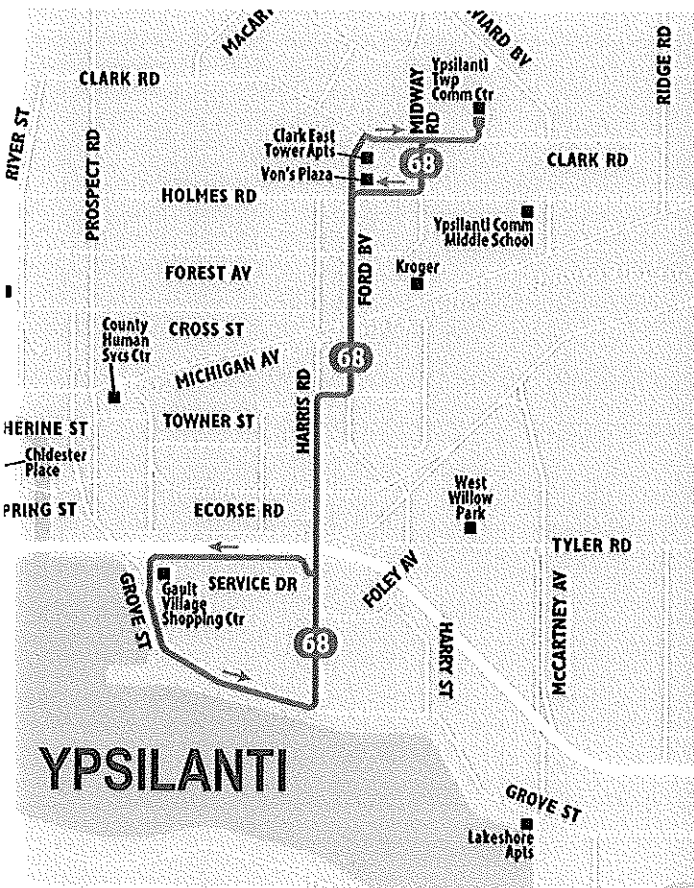

Route 68

- The Ypsilanti local routes run primarily east-west; route 68 runs north-south to provide connections
- Provides service to shopping
- Connects Clark East Towers to the Ypsilanti Twp Community Center

*The number is
staying the same...*

3

Huron River

*...but part of the
route is changing*

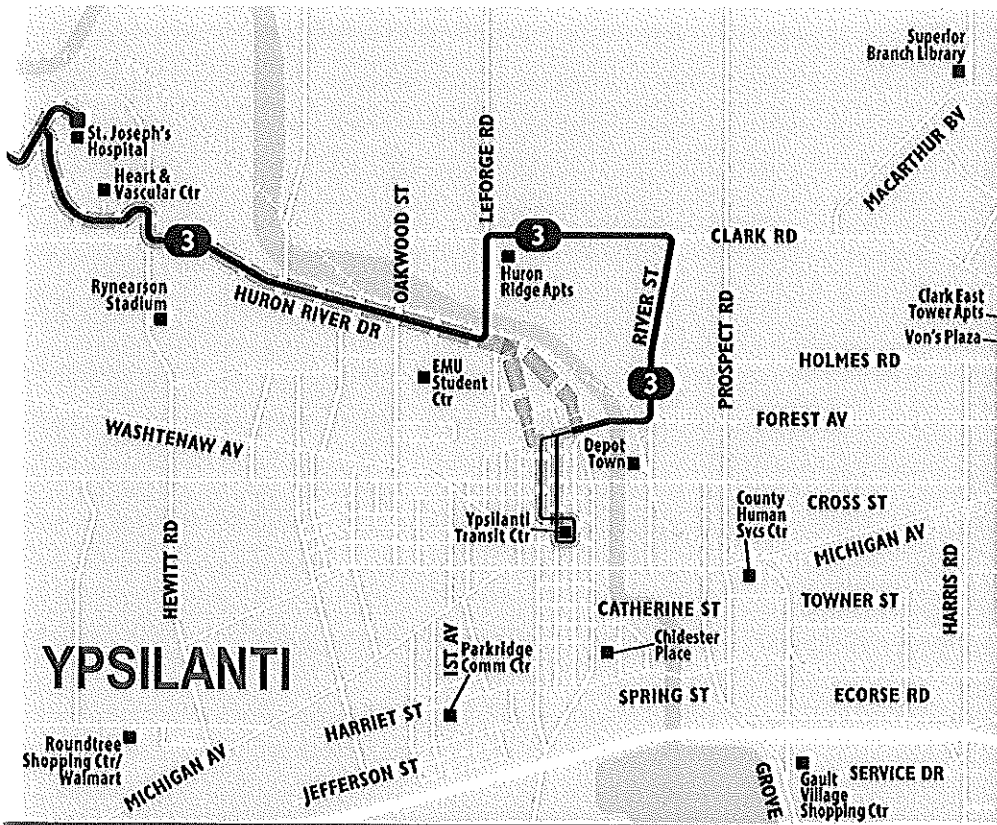

Route 3

- Providing direct connections for the apartment complexes on LeForge Rd to downtown Ypsilanti, Depot Town, WCC, and Ann Arbor

Questions?

Email: AskUs@TheRide.org

Visit: TheRideYourWay.org

Call: 734-996-0400



NEW ANN ARBOR ROUTES

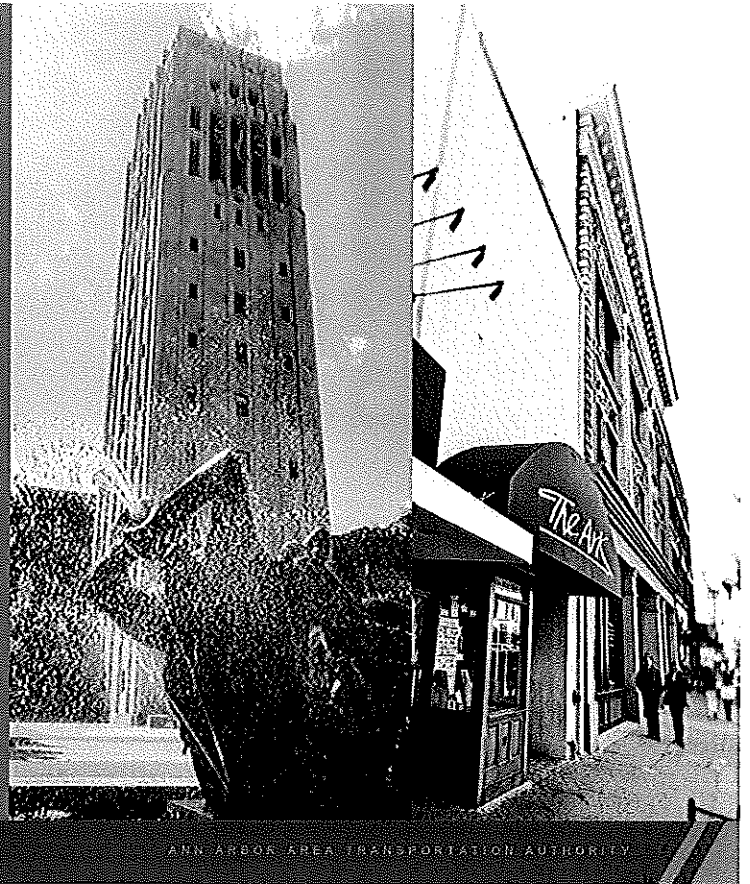

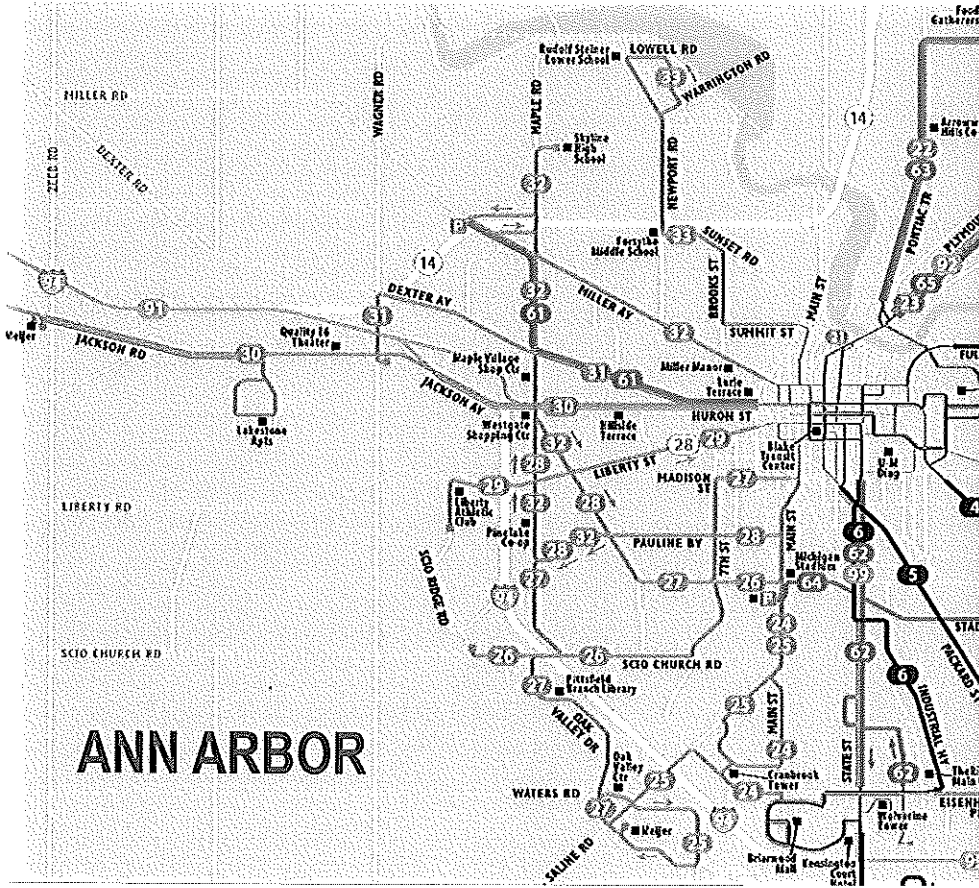

Replace
 routes
 9, 12, 15,
 and 18
 with
 six
 new
 routes

ROUTE

9

Jackson – Dexter

will be replaced by...

30

Jackson

31

Dexter



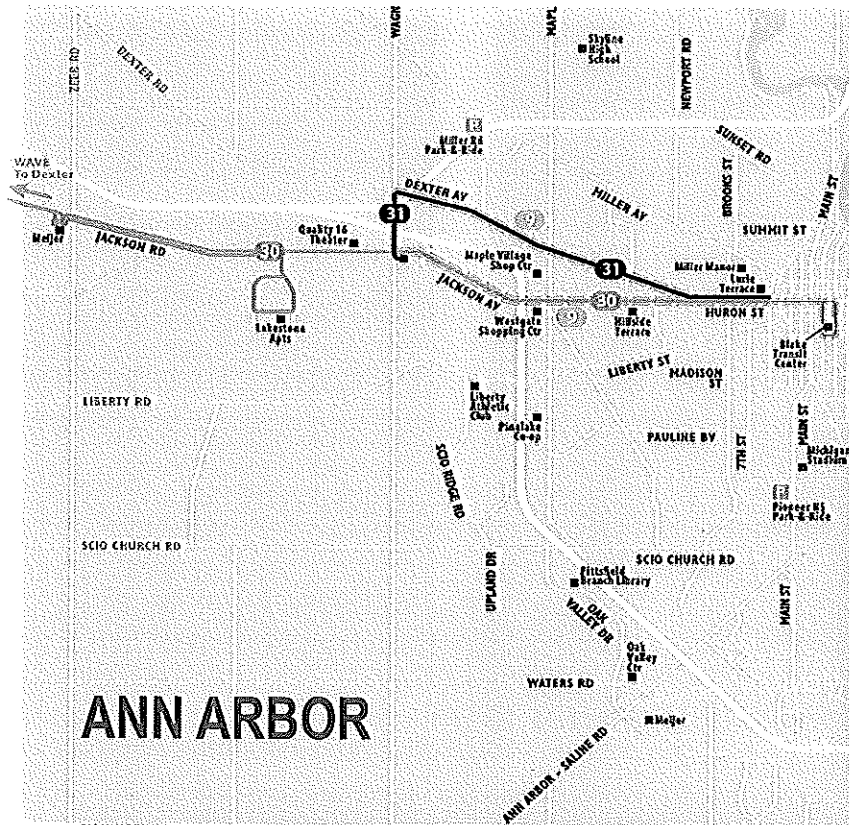

ANN ARBOR

Route 30: NEW SCIO SERVICE!

- Direct service in both directions on Jackson Rd
- Service extended to Meijer on Jackson Rd
- Coordinated transfers with WAVE at Meijer

Route 31

- Direct service in both directions on Dexter Ave
- Turns around on Jackson Rd.



ROUTES

12

Miller – Liberty

18

Miller – University

will be replaced by...

29

Liberty

32

Miller - Skyline –
W. Stadium

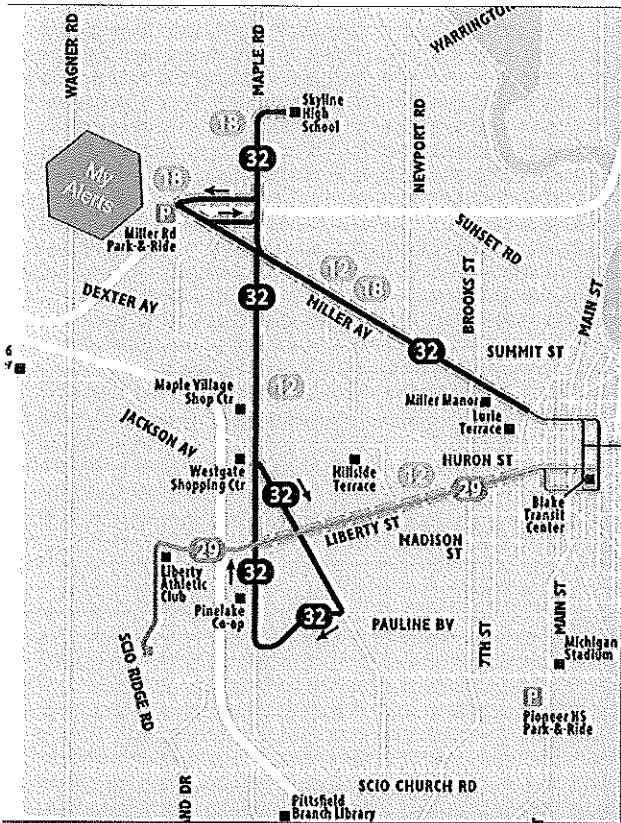

Route 29: NEW SCIO SERVICE!

- Direct service in both directions on Liberty St
- Service extended to Scio Ridge Rd.

Route 32

- Direct service in both directions on Miller Ave
- All trips serve Miller Ave & Skyline High School
- 32A trips serve Stadium Blvd & Maple Rd
- 32B & 32C trips serve the Miller Rd Park & Ride lot

ROUTE

15

Scio Church –
W. Stadium

will be replaced by...

26

Scio Church

27

W. Stadium –
Oak Valley

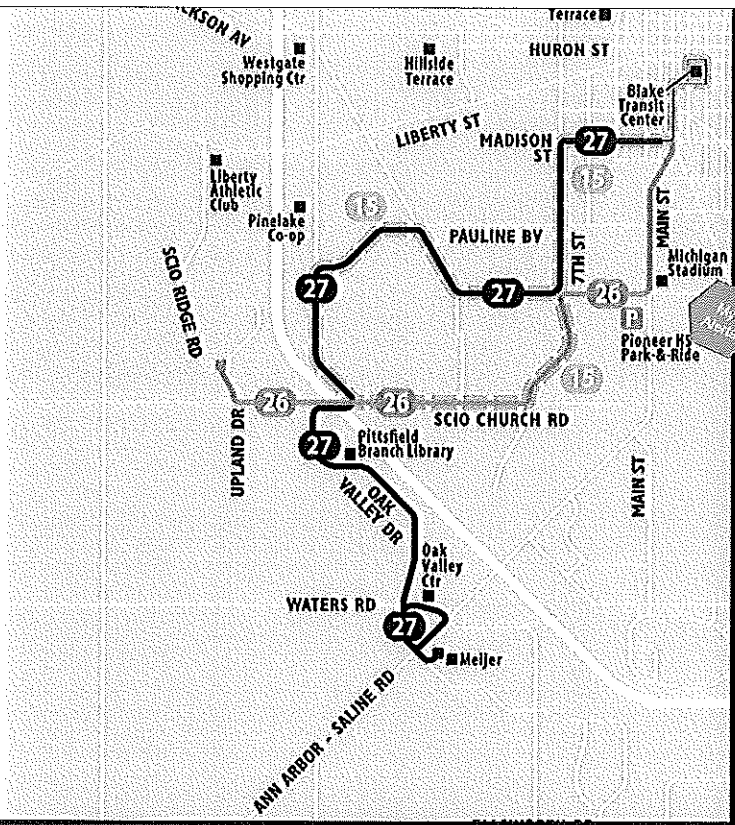

Route 26: NEW SCIO SERVICE!

- Direct service in both directions on Scio Church Rd
- Service extended to Scio Ridge Rd

Route 27

- Direct service in both directions on Seventh St & Oak Valley Dr
- Connects apartments in Pauline/Maple area to library on Oak Valley Dr and shopping in the Ann Arbor – Saline Rd area

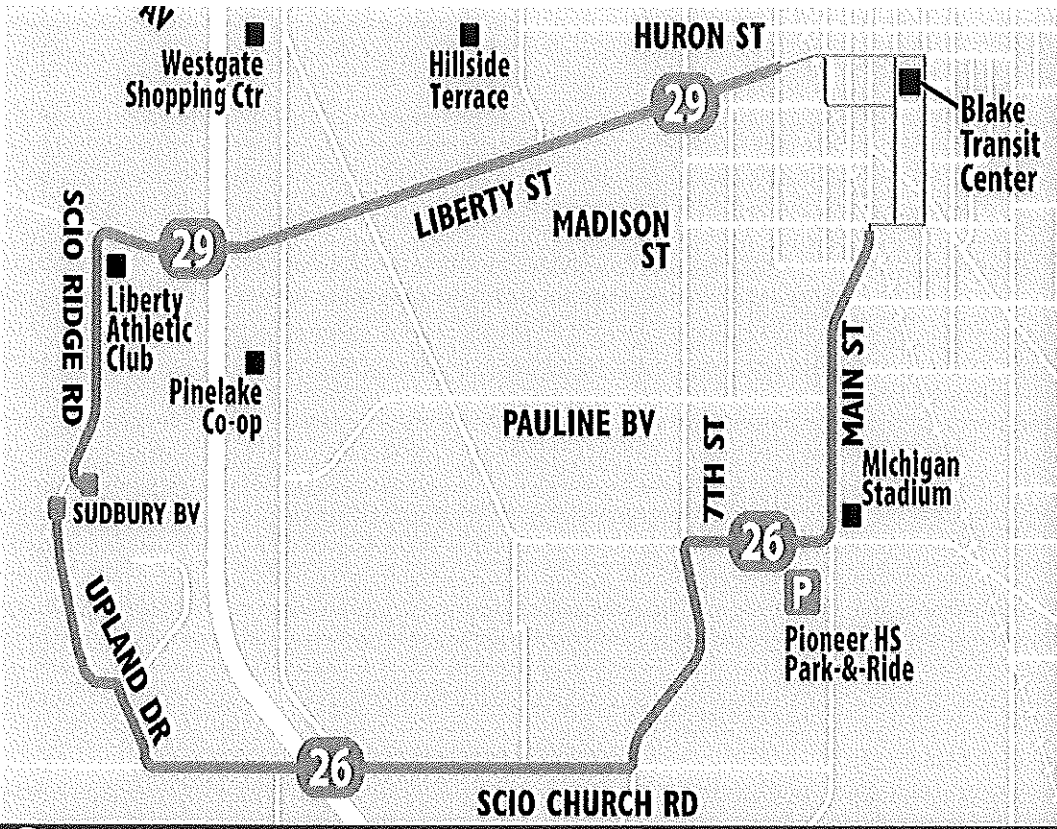

UPDATE:

Routes 26 & 29

Will be through-routed most of the time

AAATA Park and Ride Locations

State Street Lot

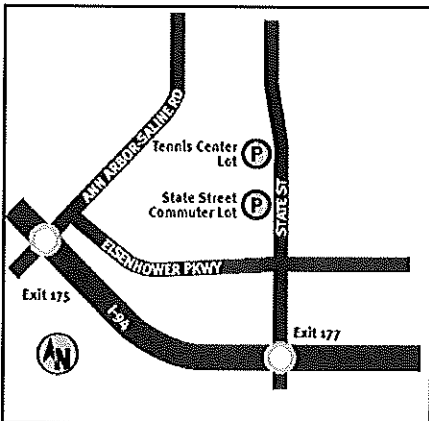

Current Route	New Route
Rt. 36	Rt. 62: U-M - State

Plymouth Rd.

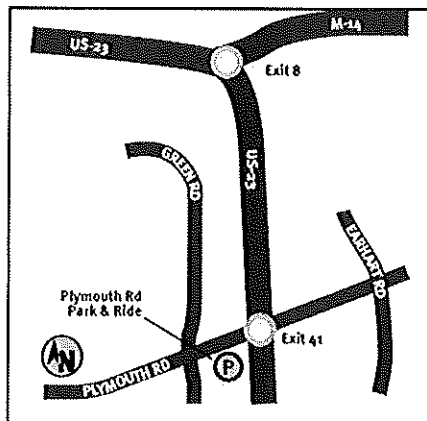

Current Rt.	New Route
Rt. 2A & 2B	Rt. 23A & 23B: Plymouth

Miller Rd. Lot

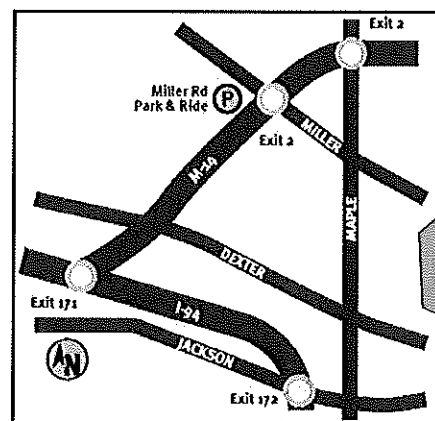

Current Route	New Rt. May 1, 2016
Rt. 12B	Rt. 32: Miller-Skyline-W. Stadium
Rt. 18	Rt. 32: Miller-Skyline-W. Stadium
Rt. 609	Rt. 60: U-M - Dexter



AAATA Park and Ride Locations

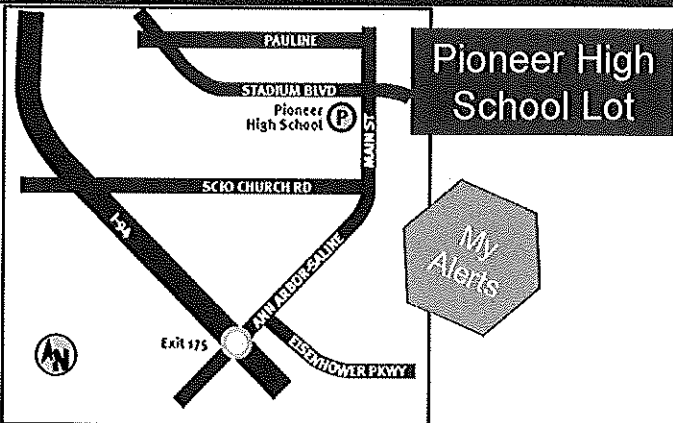

Pioneer High School Lot



Current Route	New Routes May 1, 2016
Rt. 7	Rt. 24: S. Main -East
Rt. 14	Rt. 64: Geddes - E. Stadium
Rt. 16	Rt. 25: Ann Arbor - Saline Rd.

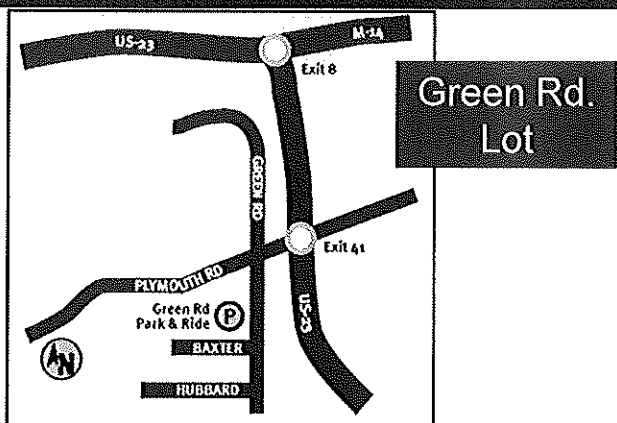

Green Rd. Lot

Current Route	New Routes May 1, 2016
Rt. 22	Rt. 66: Carpenter - Huron Pkwy
Rt. 2C	Rt. 65: U-M - Downtown - Green
Rt. 2A & 2B	Rt. 23A & 23B: Plymouth

AAATA Park and Ride Locations: Shared Use

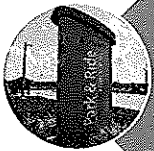

Meijer Store

- 3825 Carpenter Rd, Ypsilanti
- Spaces located just north of the IHOP Restaurant
- **Current Routes:** 5, 6 and 22
- **New Routes May 1st:** 5, 6, 66

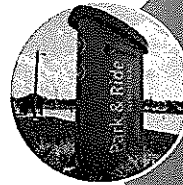

Veterans Park

- 2150 Jackson Ave, Ann Arbor
- Parking lot off of Dexter Ave.
- **Current Routes:** 9, 609
- **New Routes May 1st:** 31, 60 respectively



Washtenaw County Service Center

- 4125 Washtenaw Ave., Ann Arbor
- Designated parking on Washtenaw Ave. east of Hogback
- **Current Routes:** 4, 7, 22
- **New Routes May 1st:** 4, 24, 66



Huron Parkway

- Designated street parking between Plymouth Rd. and Nixon Rd.
- **Current Routes:** 1, 2
- **New Routes May 1st:** 22, 23(2A&B), 65(2C)

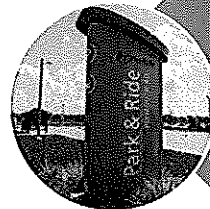

Ypsilanti Transit Center

- 220 Pearl St., Ypsilanti
- Limited space available
- Official AAATA hang tag required
- **Current Routes:** 3, 4, 5, 6, 10, 11, 20, 33, 46
- **New Routes:** 3, 4, 5, 6, 41, 42, 43, 44, 45, 46, 47,

SUPERIOR TOWNSHIP BUILDING DEPARTMENT
MONTH-END REPORT
March 2016

Category	Estimated Cost	Permit Fee	Number of Permits
Com/Multi-Family New Building	<i>\$0.00</i>	<i>\$5,046.00</i>	<i>1</i>
Electrical Permits	<i>\$0.00</i>	<i>\$3,110.00</i>	<i>15</i>
Manufactured/Modular	<i>\$0.00</i>	<i>\$300.00</i>	<i>2</i>
Mechanical Permits	<i>\$0.00</i>	<i>\$4,548.00</i>	<i>34</i>
Plumbing	<i>\$0.00</i>	<i>\$4,267.00</i>	<i>27</i>
Res-Additions (Inc. Garages)	<i>\$0.00</i>	<i>\$260.00</i>	<i>1</i>
Res-Manufactured/Modular	<i>\$0.00</i>	<i>\$150.00</i>	<i>1</i>
Res-New Building	<i>\$1,594,477.00</i>	<i>\$10,764.00</i>	<i>6</i>
Res-Other Building	<i>\$0.00</i>	<i>\$300.00</i>	<i>3</i>
Res-Other Non-Building	<i>\$0.00</i>	<i>\$300.00</i>	<i>3</i>
Res-Renovations	<i>\$0.00</i>	<i>\$444.00</i>	<i>3</i>
Totals	<i>\$1,594,477.00</i>	<i>\$29,489.00</i>	<i>96</i>

SUPERIOR TOWNSHIP BUILDING DEPARTMENT
YEAR-TO-DATE REPORT
January through March 2016

Category	Estimated Cost	Permit Fee	Number of Permits
Com/Multi-Family New Building	\$0.00	\$5,046.00	1
Com/Multi-Family Renovations	\$136,490.00	\$987.00	1
Electrical Permits	\$0.00	\$5,932.00	34
Manufactured/Modular	\$0.00	\$600.00	4
Mechanical Permits	\$0.00	\$15,053.00	102
Plumbing	\$0.00	\$10,325.00	58
Res-Additions (Inc. Garages)	\$277,000.00	\$938.00	4
Res-Manufactured/Modular	\$0.00	\$150.00	1
Res-New Building	\$4,279,561.00	\$30,532.00	16
Res-Other Building	\$8,800.00	\$500.00	5
Res-Other Non-Building	\$0.00	\$700.00	5
Res-Renovations	\$90,000.00	\$1,439.00	6
Totals	\$4,791,851.00	\$72,202.00	237

SUPERIOR TOWNSHIP FIRE DEPARTMENT

MEMO

To: Ken Schwartz, David Phillips, Brenda McKinney
CC:
From: Vic Chevrette, Fire Chief
Date: 4/4/2016
Re: Fire Chief Activity Report, March 2016

The following is the March 2016 activity report for the Fire Chief.

Fire Suppression Plan Reviews: 2

Site Plans Review: 1

Building Plan Review: 0

Inspections: 3

Fire Sprinkler Test: 4 (Fire Pumps)

Fire Alarm Test: 0

Fire Suppression Systems Test: 1

Fire Investigations: 0

Court Appearance: 2

Meetings Attended: Washtenaw County Fire Chief (WAMAA), Inspection Reports On-Line, Washtenaw Co. Local Emergency Plan Committee, Homeland Security Task Force, OHM Feasibility Study.

Training: Huron Valley Code Officials, Metro Fire Inspector Society, Task force Tips (Valprasio, IN).

Other Activity:

Respectfully Submitted

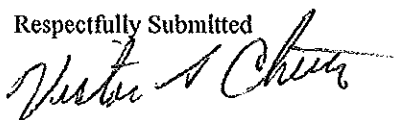

Victor G. Chevrette, Fire Chief

SUPERIOR

Incident Type Report (Summary)

Alarm Date Between {03/01/2016} And {03/31/2016}

Incident Type	Count	Pct of Incidents	Total Est Loss	Pct of Losses
1 Fire				
111 Building fire	1	0.86%	\$0	0.00%
113 Cooking fire, confined to container	1	0.86%	\$500	13.99%
118 Trash or rubbish fire, contained	1	0.86%	\$0	0.00%
131 Passenger vehicle fire	1	0.86%	\$3,072	86.00%
141 Forest, woods or wildland fire	1	0.86%	\$0	0.00%
	5	4.34%	\$3,572	100.00%
3 Rescue & Emergency Medical Service Incident				
311 Medical assist, assist EMS crew	31	26.95%	\$0	0.00%
321 EMS call, excluding vehicle accident with	36	31.30%	\$0	0.00%
322 Motor vehicle accident with injuries	2	1.73%	\$0	0.00%
324 Motor Vehicle Accident with no injuries	5	4.34%	\$0	0.00%
352 Extrication of victim(s) from vehicle	1	0.86%	\$0	0.00%
362 Ice rescue	1	0.86%	\$0	0.00%
	76	66.08%	\$0	0.00%
4 Hazardous Condition (No Fire)				
411 Gasoline or other flammable liquid spill	1	0.86%	\$0	0.00%
412 Gas leak (natural gas or LPG)	1	0.86%	\$0	0.00%
424 Carbon monoxide incident	1	0.86%	\$0	0.00%
440 Electrical wiring/equipment problem, Other	1	0.86%	\$0	0.00%
444 Power line down	1	0.86%	\$0	0.00%
445 Arcing, shorted electrical equipment	2	1.73%	\$0	0.00%
	7	6.08%	\$0	0.00%
5 Service Call				
511 Lock-out	1	0.86%	\$0	0.00%
554 Assist invalid	2	1.73%	\$0	0.00%
	3	2.60%	\$0	0.00%
6 Good Intent Call				
600 Good intent call, Other	5	4.34%	\$0	0.00%
611 Dispatched & cancelled en route	14	12.17%	\$0	0.00%
622 No Incident found on arrival at dispatch	2	1.73%	\$0	0.00%
631 Authorized controlled burning	1	0.86%	\$0	0.00%

SUPERIOR

Incident Type Report (Summary)

Alarm Date Between {03/01/2016} And {03/31/2016}

Incident Type	Count	Pct of Incidents	Total Est Loss	Pct of Losses
6 Good Intent Call	22	19.13%	\$0	0.00%
7 False Alarm & False Call				
700 False alarm or false call, Other	1	0.86%	\$0	0.00%
745 Alarm system activation, no fire -	1	0.86%	\$0	0.00%
	2	1.73%	\$0	0.00%

Total Incident Count: 115

Total Est Loss:

\$3,572

SUPERIOR

Aid Responses by Incident

Alarm Date Between {03/01/2016} And {03/31/2016}

Department	Notified	Aid Type		Fire	EMS	Resc	Other
16-0606022 03/03/2016 22:31:00							
321 EMS call, excluding vehicle accident with injury							
W M14 M10 HWY /ANN ARBOR, MI 48105							
AATW Ann Arbor Township	03/03/2016	1 Mutual aid received	#Personnel	0	0	0	0
			#Apparatus	0	0	0	0
Response Time:00:03:00							
Subtotal Responses: 1				Average Aid Response Time for Incident: 00:03:00			
16-0606363 03/07/2016 11:13:55							
118 Trash or rubbish fire, contained							
EMU Police Station / Hoyt Hall Eastern Michigan University Campus							
YPSI CITY Ypsilanti City Fire Department	03/07/2016	4 Automatic aid given	#Personnel	3	0	0	0
			#Apparatus	2	0	0	0
Their Inci 606363 Response Time:00:05:04							
Subtotal Responses: 1				Average Aid Response Time for Incident: 00:05:04			
16-0606778 03/11/2016 17:44:11							
352 Extrication of victim(s) from vehicle							
US 23 & Between the tripples /Ann Arbor, MI 48105							
AATW Ann Arbor Township	03/11/2016	3 Mutual aid given	#Personnel	0	0	2	0
			#Apparatus	0	0	1	0
Response Time:00:07:11							
Subtotal Responses: 1				Average Aid Response Time for Incident: 00:07:11			
16-0607599 03/20/2016 01:33:00							
111 Building fire							
2372 Quarterback CT							
YPSI CITY Ypsilanti City Fire Department	03/20/2016	4 Automatic aid given	#Personnel	4	0	0	0
			#Apparatus	2	0	0	0
Response Time:00:11:00							
Subtotal Responses: 1				Average Aid Response Time for Incident: 00:11:00			

Response time calculated from time notified to arrival time.

SUPERIOR

Aid Responses by Incident

Alarm Date Between {03/01/2016} And {03/31/2016}

Department	Notified	Aid Type	Fire	EMS	Resc	Other
16-0608702 03/31/2016 15:33:36						
322 Motor vehicle accident with injuries						
Ford RD & FRAINS LAKE RD						
AATW Ann Arbor Township	03/31/2016	3 Mutual aid given	#Personnel	0	1	0
			#Apparatus	0	1	0
Response Time:00:02:35						
Subtotal Responses: 1			Average Aid Response Time for Incident: 00:02:35			

60-0006009 03/03/2016 21:28:00						
440 Electrical wiring/equipment problem, Other						
855 Clark						
YPSI TWP Ypsilanti Township Fire Department	03/03/2016	3 Mutual aid given	#Personnel	0	0	0
			#Apparatus	0	0	0
Response Time:00:00:00						
Subtotal Responses: 1			Average Aid Response Time for Incident: 00:00:00			

Response time calculated from time notified to arrival time.

SUPERIOR

Dollar Value Saved & Loss Analysis

Alarm Date Between {03/01/2016} And {03/31/2016}
and Incident Type Between "100 " And "138 "

Incident Type	Count	Total Values	Total Losses	Total Saved	Percent Lost	Percent Saved
113 Cooking fire, confined to	1	\$10,000	\$500	\$9,500	5.00%	95.00%
131 Passenger vehicle fire	1	\$3,072	\$3,072	\$0	100.00%	0.00%
Grand Totals	2	\$13,072	\$3,572	\$9,500		

Total Percent Lost: 27.33%

Total Percent Saved: 72.67%

SUPERIOR

Incident List by Street Address

Alarm Date Between {03/01/2016} And {03/31/2016}
and Incident Type In "322 ", "323 ", "352 "

Incident-Exp#	Alm Date	Alm Time	Location	Incident Type
16-0606778-000	03/11/2016	17:44:11	US 23 & Between the tripp	352 Extrication of victim(s) fr
16-0606347-000	03/07/2016	08:56:00	9590 PLYMOUTH RD /PLYMOUT	322 Motor vehicle accident with
16-0608702-000	03/31/2016	15:33:36	Ford RD & FRAINS LAKE RD	322 Motor vehicle accident with

Total Incident Count 3

SUPERIOR

Incident List by Street Address

Alarm Date Between {03/01/2016} And {03/31/2016}
and Incident Type Between "730 " And "746 "

Incident-Exp#	Alm Date	Alm Time	Location	Incident Type
16-0608069-000	03/25/2016	09:36:00	5477 W CLARK RD	745 Alarm system activation, no

Total Incident Count 1

MARCH 2016

TO: KEN SCHWARTZ SUPERVISOR

FROM: SHAUN BACH - CAPTAIN

SUBJECT: HOSPITAL ALARMS

DATE: 4/1/2016

**SUPERIOR TOWNSHIP FIRE DEPARTMENT FALSE ALARM RESPONSES TO
SAINT JOSEPH HOSPITAL**

TOTAL FALSE ALARMS:

1ST. ALARM: NO CHARGE

2ND ALARM \$50.00

3RD ALARM \$200.00

TOTAL: \$0.00

ALARM LOCATIONS:

NO ST. JOE ALARMS

Superior Township Monthly Report

March/ April 2016

Resident Complaints/ Debris:

- 9761 Ravenshire- Debris on Extension- **(Removed)**
- 8632 Kingston Ct.- Debris on Extension- **(Serviced)**
- 8928 Oxford Ct.- Debris on Extension- **(Tagged for Removal)**
- 8884 Nottingham- Bags & Debris on porch- **(Spoke with owner)**
- 9272 Panama- Debris on Extension **(Serviced)**
- 8688 Heather Ct.- Table on Extension- **(Tagged for Removal)**
- 1865 Telford Ct.- T.V. on Extension- **(Tagged for Removal)**
- 9770 Ravenshire- Black Bags on Extension- **(Tagged for Removal)**
- 9240 Abbey Ln.- Chair on Extension- **(Tagged for Removal)**
- 9106 Arlington- Debris on Extension- **(Tagged for Removal)**

Yardwaste Complaints:

- 8430 Barrington Dr.- Yardwaste on Extension- **(Tagged)**
- 8465 Berkshire- Yardwaste on Extension- **(Tagged)**
- 8272 Warwick Ct.- Yardwaste on Extension- **(Tagged)**
- 8863 Somerset- Yardwaste on Extension- **(Tagged)**
- 1842 Manchester- Yardwaste on Extension- **(Tagged)**
- 8875 Nottingham- Busted yardwaste bags- **(Tagged for Removal)**
- 8343 Berkshire- Yardwaste on Extension- **(Tagged)**
- 1715 Hamlet- Yardwaste on Extension- **(Tagged)**
- 8539 Windsor Ct.- Yardwaste on Extension- **(Tagged)**
- 10181 Avondale- Yardwaste on Extension- **(Tagged)**
- 1739 Sheffield- Yardwaste on Extension- **(Tagged)**
- 1803 Hamlet- Brush in yard attracting animals- **(Letter Sent)**

Vehicle Complaints:

- 8681 Cedar Ct.- Trailer on Extension- **(Letter Sent)**
- 1771 Sheffield- Vehicle stored on lawn- **(Letter Sent)**
- 1027 McArthur Ct.- Vehicle parked on lawn- **(Tagged for Removal)**
- Kingston Ct. & Stephens Rd.- Vehicle w/ no tags- **(Letter Sent)**
- 1512 Dawn Rd.- Vehicle parked on lawn- **(Letter Sent)**

Illegal Dumping:

- Bazley and Wiard Rd.- Sofa dumped in street- **(Township Notified)**

Superior Township Park Commission
March 17, 2016
Special Meeting

Approved Minutes

- I. Call to Order
The meeting was called to order by Vice-Chair Mirada Jenkins at 6:39 pm.
- II. Roll Call
Park Commissioners present: Mirada Jenkins, Terry Lee Lansing, Marlon Morris, Sandi Lopez, Martha Kern-Boprie

Park Commissioners absent: Nahid Sanii-Yahyai

Others present: Juan Bradford, Park Administrator; Ken Schwartz, Township Supervisor
- III. Flag Salute
Vice-Chair Mirada Jenkins led those assembled in the Pledge of Allegiance to the Flag.
- IV. Agenda Approval
It was moved by Terry Lee Lansing and supported by Sandi Lopez to approve the agenda as amended, with New Business Item B. Building Healthy Communities Partnership Agreement. The motion carried.
- V. Old Business – none
- VI. New Business
 - A. Interviews for Open Parks Commissioners Seat
Letters of application for the open Parks Commissioner seat were submitted by Paula Jefferson and Diana Ravis. Neither of these individuals were present at the meeting. Both were called via telephone, and indicated they did not know the Park Commission planned to interview them. Park Commissioners decided to evaluate the applicants based on their letters of application. Several Park Commissioners noted that Diana Ravis has previously served on the Park Commission, had worked for Superior Township for several years, and could quickly and effectively assume the responsibilities of Parks Commissioner. Martha Kern-Boprie noted that this appointment is only for the remainder of the term ending 11/20/16. Anyone wishing to serve on the Parks Commission after that date must file to run as a candidate for election.

It was moved by Marion Morris and supported by Terry Lee Lansing to recommend to the Township Board that it appoint Diana Ravis to the open position on the Parks Commission for the remainder of the term ending 11/20/16. The motion carried.
 - B. Building Healthy Communities Partnership Agreement
Juan Bradford reviewed the "Building Healthy Communities Partnership Agreement" with park commissioners. This is a pilot program in a larger, multi-community grant administered by the Michigan Recreation and Parks Association (mParks). The Superior Township Partnership Agreement will provide funding of \$34,500 for the following program elements:

\$24,000.00	site improvements to Fireman's Park
\$10,000.00	staffing and programming
<u>\$ 500.00</u>	instructional materials
\$34,500.00	

Approved by Superior Township Park Commission on 3/28/2016.

The programming will consist of two programs:
Come Out and Play (COaP) focused on children
Walk with Ease (WWE) focused on senior citizens

The grant period will run from 3/01/16 through 9/30/16. The Parks Commission was asked to make a recommendation to the Township Board about this grant and partnership agreement.

It was moved by Martha Kern-Boprie and supported by Marion Morris to recommend to the Township Board that it approve the Building Healthy Communities 2016 grant Partnership Agreement for \$34,500.00. The motion carried.

VII. Pleas and Petitions

VIII. Adjournment

It was moved by Terry Lee Lansing and supported by Marion Morris to adjourn the meeting at 7:28 pm. The motion carried

Submitted by,
Martha Kern-Boprie, Park Commissioner and Secretary

Superior Charter Township Park Commission
Regular Meeting
February 22, 2016

Approved Minutes

- I. Call to Order
The meeting was called to order by Vice-Chair Mirada Jenkins at 6:30 pm.
- II. Roll Call
Park Commissioners present: Mirada Jenkins, Nahid Sanii-Yahyai, Marion Morris, Sandi Lopez, Terry Lee Lansing, Martha Kern-Boprie

Park Commissioners absent: none

Other present: Trustee Alex Williams; Juan Bradford, Park Administrator; Supervisor Ken Schwartz; Patrick Pigott, Recreation Coordinator; Tom Brennan, Keith Lockie, Diana Ravis, Lindsey Wooten, Mary Mikolosovich, Paula Jefferson
- III. Flag Salute
Vice-Chair Mirada Jenkins led those assembled in the Pledge of Allegiance to the Flag.

Ms. Jenkins asked all present to join in a moment of silence in memory of Commissioner Jan Berry who died on February 4.
- IV. Agenda Approval
It was moved by Nahid Sanii-Yahyai and supported by Terry Lee Lansing to approve the agenda as drafted. The motion carried.
- V. Prior Meeting Minutes Approval
A. January 25, 2016
It was moved by Sandi Lopez and supported by Marion Morris to approve the minutes of 1/25/16 as drafted. The motion carried.
- VI. Citizen Participation
Several members of the audience introduced themselves to the Park Commission, including Paula Jefferson, Mary Mikolosovich, Lindsey Wooten, Diana Ravis, Tom Brennan and Jack Smiley.

Ken Schwartz, Township Supervisor spoke about remembrances to Jan Berry by the Township Board, and about information gathered in successful bee keeping.

It was moved by Terry Lee Lansing and supported by Marion Morris to amend the agenda by adding to New Business: item C Request from Jack Smiley concerning Clark Road property. The motion to amend the agenda carried.
- VII. Reports
A. Chairperson
Vice-Chair Mirada Jenkins informed Park Commissioners that a celebration of Jan Berry's life will take place on May 4 at the Matthaei Botanical Gardens

B. Administrator
Juan Bradford submitted a written report. He added an update from the Michigan Recreation and Park Association (MRPA) conference last week. Superior Township will be part of a pilot program grant involving several other communities in Michigan. Participation in this grant will require

addition of a part-time administrative support staff member. Juan estimates the staff member will cost approximately \$5,000 in 2016, and will bring in up to \$10,000 for programming and up to \$24,000 for park improvements. The staff member will have to be in place by early April. Park Commissioners asked Juan to bring a proposed job description for the staff person to the March commission meeting.

C. Board Liaison

Trustee Alex Williams reported on the 2/16/16 Township Board meeting. Redwood submitted another area plan for property adjacent to Bromley Park. The Township Board's annual meeting with the Road Commission is scheduled on 3/18/16. The Township Board held a moment of silence in memory of Jan Berry and Charles Swanson. Ypsilanti Community Schools propose closing more school buildings. At this point we do not know what will be done with Cheney School in Superior Township. Significant road repair is necessary to a bridge on Cherry Hill Road between Gotfredson and Napier Roads. The township is covering part of the cost of that repair. The State of Michigan has sued Fairfax Manor, seeking to close three of its units. The Fire Chief is getting a vehicle. The Redwood area plan was tabled for factfinding. The township adopted the 2012 Fire Code, which is the most recent update. Minor corrections were made to the township zoning map.

D. Board Meeting Attendee

Mirada Jenkins attended the 2/16/16 Township Board meeting. She reported that dead trees along roadsides would be removed by DTE Energy.

E. Park Steward

No report.

F. Safety

There have been no accidents or injuries in the past month.

It was moved by Nahid Sanii-Yahyai and supported by Marion Morris to receive the reports. The motion carried.

VIII. Communications

- A. 2016 Events Flyer
- B. Restoring Nature with Fire pamphlet
- C. Parks & Recreation Fact Sheet: Parks and Healthy Kids

It was moved by Nahid Sanii-Yahyai and supported by Marion Morris to receive the communications. The motion carried.

IX. Old Business – none

X. New Business

A. CHNP Prescribed Burn

A proposal to conduct a prescribed burn in Cherry Hill Nature Preserve (CHNP) by David Borneman, LLC for \$3,700.00 was reviewed by Park Commissioners. Mr. Borneman and his company have conducted prescribed burns previously and successfully. It was moved by Martha Kern-Boprie and supported by Sandi Lopez to approve the proposal from David Borneman, LLC to conduct a prescribed burn in CHNP for an amount not to exceed \$3,700.00. A roll call vote was taken.

<u>Commissioner</u>	<u>Yes</u>	<u>No</u>	<u>Absent</u>	<u>Abstain</u>
Mirada Jenkins	X			
Martha Kern-Boprie	X			
Marion Morris	X			
Nahid Sanii-Yahyai	X			
Sandi Lopez	X			

Terry Lee Lansing X

The motion carried.

B. Commission Vacancy

Supervisor Ken Schwartz informed the Park Commission that applications for the open position on the Park Commission are due to his office by Monday, March 14.

Park Commissioners agreed to schedule a special meeting on Thursday, March 17 to interview all applicants. Juan Bradford will make copies of all applications available to Park Commissioners pm Tuesday, March 15. The Park Commission will endeavor to send its recommendation to the Township Board in time for the March 22 meeting of the Township Board.

Park Commissioners asked Supervisor Schwartz to update the website posting about the Park Commission opening with the information that nominating petitions for the term commencing November 20, 2016 are due to the Township Clerk, with the due date.

C. Jack Smiley presentation about 325 E. Clark Road

Jack Smiley introduced himself to Park Commissioners as representative of the SouthEast Michigan Land Conservancy and Superior Land Conservancy and particularly the Superior Greenways project. He reviewed a map containing parcels in Superior Township that have been acquired or otherwise protected from development. He seeks to have the Washtenaw County Natural Areas Preservation Program (NAPP) purchase a parcel of approximately 53 acres at 325 E. Clark Road in Superior Township. This parcel is on the north side of Clark Road, between River Street and LeForge Road. Acquiring this parcel will make a big step toward an unbroken greenway from Clark Road north to the township hall on Cherry Hill Road. Mr. Smiley asked the Park Commission to recommend purchase of this parcel by the NAPP to both the County Park and Recreation Commission and the Superior Township Board.

It was moved by Martha Kern-Boprie and supported by Marion Morris that the Superior Township Park Commission recommend to the Washtenaw County Park Commission and the Superior Charter Township Board acquisition of a parcel of approximately 53 acres at 325 E. Clark Road in Superior Township by the Washtenaw County Natural Areas Preservation Program. The motion carried.

XI. Bills for Payment

It was moved by Marion Morris and supported by Terry Lee Lansing to approve payment of the bills totaling \$27,163.32. The motion carried.

XII. Financial Statements

January 31, 2016 Financial Statements were reviewed by Park Commissioners. Terry Lee Lansing noted that Taxable Benefits for Maintenance Staff was over budget already, and asked why. Sandi Lopez also asked about this item. Keith Lockie responded the budget was too low, and would be corrected with a budget amendment.

It was moved by Marion Morris and supported by Sandi Lopez to receive the January Financial Statements. The motion carried.

XIII. Pleas and Petitions

Marion Morris recommended dedicating the new CHNP board walk to Jan Berry's memory. She suggested a boulder placed near the boardwalk. Marion will collaborate with Juan Bradford on this.

Ken Schwartz commented that the jail work crew could plant some spruce trees in our parks. The Park Commission could make decisions about this suggestion at the March commission meeting in time to order the trees.

Approved by Superior Township Park Commission on 3/28/2016.

XIV. Adjournment

It was moved by Sandí Lopez and supported by Marion Morris to adjourn the meeting at 7:45 pm. The motion carried.

Submitted by,
Martha Kern-Boprie, Park Commissioner and Secretary

Memorandum

To: Superior Township Board of Trustees
From: Keith Lockie
Date: April 18, 2016
Re: Utility Department Report

- C of O Inspections continue, with all passing.
- The replacement of MXUs continues. These MXUs, for the most part, are the original MXUs installed when the Township first went to radio reads.
- Treasury personnel are currently being trained on processing Utility Bill payments at Township Hall. In the future, residents will be offered two locations for in-person Utility Bill payment: Utility Admin. Building and Township Hall.
- The 2015 Audit occurred for all funds, including the Utility Fund, the week of March 28th at Township Hall. For the Utility Fund there were no problems identified. A short synopsis of 2015 Utility Classes:

1. O&M	\$72,479 Profit
2. Cap. Res.	91,101 Loss
3. Sys. Rep. Res.	1,175 Profit
4. Debt. Serv.	<u>67,590 Loss</u>
Total	\$85,038 Loss
2014 Total	190,158 Loss

- For 2015, we had a total of 52 Connection Permits, which generated \$540,500:

1. Prospect Pointe	25 Total
2. Woodlands of Geddes	15
3. Prospect Pointe East	12

- For 2016-to-date, we've had a total of 18 Connection Permits, which has generated \$189,000:

1. Prospect Pointe East	10 Total
2. Prospect Pointe	8



WASHTENAW COUNTY OFFICE OF THE SHERIFF



JERRY L. CLAYTON
SHERIFF

2201 Hogback Road ♦ Ann Arbor, Michigan 48105-9732 ♦ OFFICE (734) 971-8400 ♦ FAX (734) 973-4624 ♦ EMAIL sheriff@ewashtenaw.org

MARK A. PTASZEK
UNDERSHERIFF

April 8, 2016

TO: Ken Schwartz, Superior Township Supervisor
FR: Mike Trester, Lieutenant (Ann Arbor, Salem, Superior and York Townships)
TH: Marlene Radzik, Commander
RE: March 2016 Police Services Monthly Report

In March of 2016 there were 772 calls for service in Superior Township, compared to 821 in March 2015.

For the month of March deputies initiated 201 traffic stops and issued 45 citations.

Information on **significant events** this month includes:

- Friday March 4, 5700 Block of Tanglewood, Larceny from Vehicle, tires stolen off vehicle, Deputy Hankamp OIC, 16-16559
- Saturday March 5, Huron River/ Hewitt OWI arrest, Deputy Thompson OIC, 16-16819
- Wednesday March 9, 1500 Block of Devon St, Larceny from Vehicle, windows left open, tools and money stolen, Deputy Ross OIC, 16-18015
- Saturday March 12, Leforge/ Geddes, OWI arrest Deputies Rex/ Campbell OIC, 16-18969
- Sunday March 13, 8800 Block of MacArthur, Robbery, suspect known Deputy Losey OIC, 16-19264
- Sunday March 13, Clark/ Prospect OUID arrest Deputy Smith OIC, 16-19394
- Monday March 14, 1515 Ridge Road, Robbery, suspect known, Deputy Hankamp OIC, 16-19431
- Saturday March 19, 8700 block of MacArthur, Felony warrant arrest, Deputy Traskos OIC, 16-20990
- Saturday March 19, 9200 Block of MacArthur, Home invasion, entry through unsecured sliding glass door, TV stolen, Deputy Carter OIC, 16-21066
- Sunday March 20, MacArthur/ Harris OWI arrest, Deputies Parker and Hall OIC, 16-21250
- Wednesday March 23, 6500 Geddes Road, Larceny from Building, 5 cell phones stolen, Deputy Losey OIC, 16-22122
- Friday March 25, Prospect and Clark, Felony Warrant arrest, Deputy Rush OIC, 16-22597
- Friday March 25, 9300 Block of MacArthur, Home Invasion, entry through unlocked patio door, electronic items taken, Deputy Erbes, Gebauer OIC, 16-23167
- Monday March 28, Prospect and Cherry Hill OWI arrest, Deputy Hall OIC, 16-23395

Public Safety – Quality Service – Strong Communities

- Thursday March 31, 1900 Prospect, Felony warrant arrest, Deputy Ross OIC, 16-24266
- Thursday March 31, 9300 Block of MacArthur, AWIM, 4 shots fired into a residence, no one injured, Deputies Parker and Hall OIC, 16-24400

CLR-008 Monthly Summary Of Offenses (WD)

City:Superior Twp-SUT

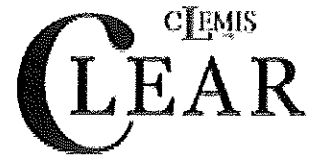

Month:	March
Year:	2016
Print Option:	Print Both Monthly and YTD
Include Unfounded:	No
Report Offenses:	Include All (1,2,3,4)
Attempted/Completed/NA:	Includes Attempted, Completed
City:	Superior Twp-SUT

CLR-008 Monthly Summary Of Offenses (WD)

City:Superior Twp-SUT

For The Month Of March

Classification	Mar/2015	Mar/2016	%Change
09001 MURDER/NONNEGLIGENT MANSLAUGHTER (VOLUNTARY)	0	0	0%
10002 PARENTAL KIDNAPPING	0	0	0%
11001 SEXUAL PENETRATION PENIS/VAGINA -CSC 1ST DEGREE	1	1	0%
11003 SEXUAL PENETRATION ORAL/ANAL -CSC 1ST DEGREE	0	1	0%
11007 SEXUAL CONTACT FORCIBLE -CSC 2ND DEGREE	0	0	0%
12000 ROBBERY	0	1	0%
13001 NONAGGRAVATED ASSAULT	8	9	12.5%
13002 AGGRAVATED/FELONIOUS ASSAULT	6	2	-66.6%
13003 INTIMIDATION/STALKING	1	1	0%
22001 BURGLARY -FORCED ENTRY	2	1	-50%
22002 BURGLARY -ENTRY WITHOUT FORCE (Intent to Commit)	1	2	100%
23003 LARCENY -THEFT FROM BUILDING	4	2	-50%
23005 LARCENY -THEFT FROM MOTOR VEHICLE	0	1	0%
23006 LARCENY -THEFT OF MOTOR VEHICLE PARTS/ACCESSORIES	1	1	0%
23007 LARCENY -OTHER	1	0	-100%
24001 MOTOR VEHICLE THEFT	1	0	-100%
25000 FORGERY/COUNTERFEITING	0	1	0%
26001 FRAUD -FALSE PRETENSE/SWINDLE/CONFIDENCE GAME	2	3	50%
26002 FRAUD -CREDIT CARD/AUTOMATIC TELLER MACHINE	1	0	-100%
26007 FRAUD - IDENTITY THEFT	1	3	200%
27000 EMBEZZLEMENT	0	1	0%
28000 STOLEN PROPERTY	0	0	0%
29000 DAMAGE TO PROPERTY	4	7	75%
35001 VIOLATION OF CONTROLLED SUBSTANCE ACT	4	5	25%
35002 NARCOTIC EQUIPMENT VIOLATIONS	0	3	0%
52001 WEAPONS OFFENSE- CONCEALED	0	1	0%
52003 WEAPONS OFFENSE -OTHER	0	0	0%
Group A Totals	38	46	21.05%
22003 BURGLARY - UNLAWFUL ENTRY (NO INTENT)	1	0	-100%
36004 SEX OFFENSE -OTHER	0	1	0%
38001 FAMILY -ABUSE/NEGLECT NONVIOLENT	2	0	-100%
41002 LIQUOR VIOLATIONS -OTHER	0	3	0%
48000 OBSTRUCTING POLICE	2	2	0%
49000 ESCAPE/FLIGHT	0	1	0%
50000 OBSTRUCTING JUSTICE	1	5	400%
53001 DISORDERLY CONDUCT	0	0	0%
53002 PUBLIC PEACE -OTHER	0	1	0%
54001 HIT and RUN MOTOR VEHICLE ACCIDENT	1	1	0%
54002 OPERATING UNDER THE INFLUENCE OF LIQUOR OR DRUGS	4	7	75%
55000 HEALTH AND SAFETY	0	1	0%
57001 TRESPASS	4	3	-25%
70000 JUVENILE RUNAWAY	1	0	-100%
73000 MISCELLANEOUS CRIMINAL OFFENSE	0	0	0%

CLR-008 Monthly Summary Of Offenses (WD)

City:Superior Twp-SUT

Group B Totals		16	25	56.25%
2800	JUVENILE OFFENSES AND COMPLAINTS	1	9	800%
2900	TRAFFIC OFFENSES	3	6	100%
3000	WARRANTS	13	17	30.76%
3100	TRAFFIC CRASHES	32	23	-28.1%
3200	SICK / INJURY COMPLAINT	13	23	76.92%
3300	MISCELLANEOUS COMPLAINTS	163	178	9.202%
3400	WATERCRAFT COMPLAINTS / ACCIDENTS	1	1	0%
3500	NON-CRIMINAL COMPLAINTS	173	214	23.69%
3700	MISCELLANEOUS TRAFFIC COMPLAINTS	267	137	-48.6%
3800	ANIMAL COMPLAINTS	22	12	-45.4%
3900	ALARMS	36	29	-19.4%
Group C Totals		724	649	-10.3%
4000	HAZARDOUS TRAFFIC CITATIONS / WARNINGS	0	0	0%
4200	PARKING CITATIONS	1	0	-100%
4500	MISCELLANEOUS A THROUGH UUUU	1	0	-100%
Group D Totals		2	0	-100%
5100	18A STATE CODE FIRE CLASSIFICATIONS	0	0	0%
Group E Totals		0	0	0%
6000	MISCELLANEOUS ACTIVITIES (6000)	2	9	350%
6100	MISCELLANEOUS ACTIVITIES (6100)	34	36	5.882%
6300	CANINE ACTIVITIES	0	1	0%
6500	CRIME PREVENTION ACTIVITIES	2	2	0%
6600	COURT / WARRANT ACTIVITIES	0	0	0%
6700	INVESTIGATIVE ACTIVITIES	3	4	33.33%
Group F Totals		41	52	26.82%
City : Superior Twp Totals		821	772	-5.96%

CLR-008 Monthly Summary Of Offenses (WD)

City:Superior Twp-SUT

		Year To Date Through March		
Classification		2015	2016	%Change
Group F Totals		0	0	0%
09001	MURDER/NONNEGLIGENT MANSLAUGHTER (VOLUNTARY)	1	0	-100%
10002	PARENTAL KIDNAPPING	0	1	0%
11001	SEXUAL PENETRATION PENIS/VAGINA -CSC 1ST DEGREE	1	2	100%
11003	SEXUAL PENETRATION ORAL/ANAL -CSC 1ST DEGREE	0	2	0%
11007	SEXUAL CONTACT FORCIBLE -CSC 2ND DEGREE	1	0	-100%
12000	ROBBERY	1	3	200%
13001	NONAGGRAVATED ASSAULT	25	34	36%
13002	AGGRAVATED/FELONIOUS ASSAULT	10	5	-50%
13003	INTIMIDATION/STALKING	3	2	-33.3%
22001	BURGLARY -FORCED ENTRY	14	8	-42.8%
22002	BURGLARY -ENTRY WITHOUT FORCE (Intent to Commit)	3	3	0%
23003	LARCENY -THEFT FROM BUILDING	9	5	-44.4%
23005	LARCENY -THEFT FROM MOTOR VEHICLE	13	4	-69.2%
23006	LARCENY -THEFT OF MOTOR VEHICLE PARTS/ACCESSORIES	1	1	0%
23007	LARCENY -OTHER	4	5	25%
24001	MOTOR VEHICLE THEFT	4	2	-50%
25000	FORGERY/COUNTERFEITING	1	1	0%
26001	FRAUD -FALSE PRETENSE/SWINDLE/CONFIDENCE GAME	3	5	66.66%
26002	FRAUD -CREDIT CARD/AUTOMATIC TELLER MACHINE	3	2	-33.3%
26007	FRAUD - IDENTITY THEFT	2	4	100%
27000	EMBEZZLEMENT	0	1	0%
28000	STOLEN PROPERTY	1	0	-100%
29000	DAMAGE TO PROPERTY	11	18	63.63%
35001	VIOLATION OF CONTROLLED SUBSTANCE ACT	12	12	0%
35002	NARCOTIC EQUIPMENT VIOLATIONS	1	5	400%
52001	WEAPONS OFFENSE- CONCEALED	0	4	0%
52003	WEAPONS OFFENSE -OTHER	0	1	0%
Group A Totals		124	130	4.838%
22003	BURGLARY - UNLAWFUL ENTRY (NO INTENT)	1	1	0%
36004	SEX OFFENSE -OTHER	0	1	0%
38001	FAMILY -ABUSE/NEGLECT NONVIOLENT	2	2	0%
41002	LIQUOR VIOLATIONS -OTHER	1	3	200%
48000	OBSTRUCTING POLICE	5	7	40%
49000	ESCAPE/FLIGHT	0	2	0%
50000	OBSTRUCTING JUSTICE	2	9	350%
53001	DISORDERLY CONDUCT	1	4	300%
53002	PUBLIC PEACE -OTHER	0	1	0%
54001	HIT and RUN MOTOR VEHICLE ACCIDENT	1	1	0%
54002	OPERATING UNDER THE INFLUENCE OF LIQUOR OR DRUGS	6	9	50%
55000	HEALTH AND SAFETY	1	3	200%
57001	TRESPASS	7	6	-14.2%
70000	JUVENILE RUNAWAY	2	1	-50%

CLR-008 Monthly Summary Of Offenses (WD)

City: Superior Twp-SUT

		Year To Date Through March		
Classification		2015	2016	%Change
73000	MISCELLANEOUS CRIMINAL OFFENSE	2	0	-100%
Group B Totals		31	50	61.29%
2800	JUVENILE OFFENSES AND COMPLAINTS	11	17	54.54%
2900	TRAFFIC OFFENSES	6	9	50%
3000	WARRANTS	37	39	5.405%
3100	TRAFFIC CRASHES	115	82	-28.6%
3200	SICK / INJURY COMPLAINT	56	48	-14.2%
3300	MISCELLANEOUS COMPLAINTS	466	473	1.502%
3400	WATERCRAFT COMPLAINTS / ACCIDENTS	1	1	0%
3500	NON-CRIMINAL COMPLAINTS	503	662	31.61%
3700	MISCELLANEOUS TRAFFIC COMPLAINTS	721	376	-47.8%
3800	ANIMAL COMPLAINTS	42	28	-33.3%
3900	ALARMS	126	137	8.730%
Group C Totals		2084	1872	-10.1%
4000	HAZARDOUS TRAFFIC CITATIONS / WARNINGS	2	0	-100%
4200	PARKING CITATIONS	4	2	-50%
4500	MISCELLANEOUS A THROUGH UUUU	8	2	-75%
Group D Totals		14	4	-71.4%
5100	18A STATE CODE FIRE CLASSIFICATIONS	1	0	-100%
Group E Totals		1	0	-100%
6000	MISCELLANEOUS ACTIVITIES (6000)	20	19	-5%
6100	MISCELLANEOUS ACTIVITIES (6100)	70	79	12.85%
6300	CANINE ACTIVITIES	1	3	200%
6500	CRIME PREVENTION ACTIVITIES	9	8	-11.1%
6600	COURT / WARRANT ACTIVITIES	1	2	100%
6700	INVESTIGATIVE ACTIVITIES	12	10	-16.6%
Group F Totals		113	121	7.079%
City : Superior Twp Totals		2367	2177	-8.02%

Washtenaw County Sheriff's Activity Log

Individual Deputy Statistical Report

Date Range: 3/1/2016 - 3/31/2016

Superior Twp/Ann Arbor Twp

Shifts	Shifts	W/Partner	Service Requests	Traffic Stops	Reports Written	UD-10s	SR & TS	Ending In	Arrest	Misdemeanor Arrests (SI)	Felony Arrests (SI)	Self Initiated	Warrant	Arrests	Warrant Meets /	Pick Ups	Misdemeanor Citations	Civil Infractions	Parking Citations	OUIL Arrests	
	1																				
966 ADKINS JR, PAUL BLAKE	1		0	1	0	0	0	0	0	0	0	0	0	0	0	0	0	2	0	0	0
930 BALLARD, JOSEPH C	2		3	1	0	0	0	0	0	0	0	0	0	0	0	0	0	1	0	0	0
2071 BYNUM, L'SHANE D	26	5	42	23	16	6	6	0	0	0	0	0	0	0	1	0	0	6	0	0	1
991 CAMPBELL, JOHN WILLIAM	22		39	22	11	2	0	0	6	0	0	0	0	0	0	0	0	0	0	0	0
1810 CARTER, ANDREW N	2		2	0	0	0	0	0	0	0	0	0	0	0	0	0	0	0	0	0	0
2164 COUCH, THOMAS R	19		37	15	8	1	0	0	1	0	0	0	0	0	0	0	0	0	0	0	0
351 CROVA, JOSEPH MARIO	2		4	0	0	0	0	0	0	0	0	0	0	0	0	0	0	0	0	0	0
1775 FARMER HEWITT, HOLLY C	1				0	0	0	0	0	0	0	0	0	0	0	0	0	0	0	0	0
597 FLINT, CYNTHIA MARIE	18	4	19	34	3	0	0	0	1	2	2	1	0	0	0	0	0	3	0	0	0
1763 GEBAUER, JOEL J	2				0	0	0	0	0	0	0	0	0	0	0	0	0	0	0	0	0
793 GONTARSKI, JEFFREY ROBERT	1		1	0	1	0	0	0	1	0	0	0	0	0	0	0	0	0	0	0	0
1177 GORNEY, JOHN ARTHUR	18	2	21	29	11	1	7	7	7	1	1	5	0	0	0	0	0	1	0	0	1
2140 HALL, MICHAEL S	22	1	27	13	15	1	1	1	1	1	1	0	0	0	0	0	0	2	7	0	1
832 HANKAMP, JEFFREY LAMAR	1		1	1	1	0	0	0	0	0	0	0	0	0	0	0	0	1	0	0	0
322 HARVEY JR, JEFFREY CRAIG	2		0	2	0	0	0	0	0	0	0	0	0	0	0	0	0	0	0	0	0
744 HILOBUK, JEREMY MICHAEL	1		0	1	1	0	0	0	0	0	0	0	0	0	0	0	0	0	0	0	0
1986 HOUK, RICHARD A	19		44	5	13	1	0	0	0	0	1	0	0	0	0	0	0	5	0	0	0
958 LOSEY, ROBERT MICHAEL	19		31	10	4	1	0	0	0	0	0	0	0	0	0	0	0	3	0	0	0
1802 MCGRADY, PATRICK T	1				0	0	0	0	0	0	0	0	0	0	0	0	0	0	0	0	0
1803 MONTGOMERY, JOSEPH J	2		4	0	1	1	0	0	0	0	0	0	0	0	0	0	0	0	0	0	0
2096 MORSEY, AHMED M	1		0	7	0	0	0	0	0	0	0	0	0	0	0	0	0	0	0	0	0
336 PASTERNAK JR, ROBERT J	18	3	19	20	6	0	2	1	1	0	0	3	0	0	0	0	0	4	0	0	0
1918 PELTIER, SHANE C		1																			
952 REX, BRIAN ANDREWS	4		6	10	1	0	2	0	0	0	0	1	0	0	0	0	0	0	0	0	1
1999 RICHARDSON, JEREMIAH J	1		2	0	0	0	0	0	0	0	0	0	0	0	0	0	0	0	0	0	0
1137 RISHA, MATTHEW	2		0	4	0	0	0	0	0	0	0	0	0	0	0	0	0	0	0	0	0
2087 ROBERTS, BRANDON D	22		74	16	20	1	1	1	0	0	0	3	0	0	0	0	0	0	0	0	0
1050 ROSS, JEREMY DAVID	19	4	31	10	10	0	0	0	0	0	0	0	0	0	0	0	0	1	1	0	0
1780 SMITH, JESSE N	21		32	14	20	8	0	0	0	0	0	0	0	0	0	0	0	10	0	0	0
267 STANTON, ROBERT DAVID																					

2170 TRASKOS, RICHARD T	1	1	2	0	0	0	0	0	0	0	0	0	0	0	0	0	0	0	0
1788 VANTUYL, MARK A	2	5	1	0	0	0	0	0	0	0	0	0	0	0	0	0	0	0	0
468 WALLEN, STEVEN HENRY	3	0	5	0	0	0	0	0	0	0	0	0	0	0	0	0	0	0	0
2097 WARD, BRIAN D	1	3	1	1	1	0	0	0	0	0	0	0	0	0	0	0	0	0	0
1807 WION, JESSICA M	1	1	1	0	0	0	0	0	0	0	0	0	0	0	0	0	0	0	0
1758 YEAGER, BRIAN S	2	1	1	5	0	0	0	0	0	0	0	0	0	0	0	0	0	0	0
Grand Total:	279	22	351	260	140	24	13	18	5	15	1	19	48	0	0	0	0	0	4

Superior Township Four Year Activity Report – MARCH, 2016

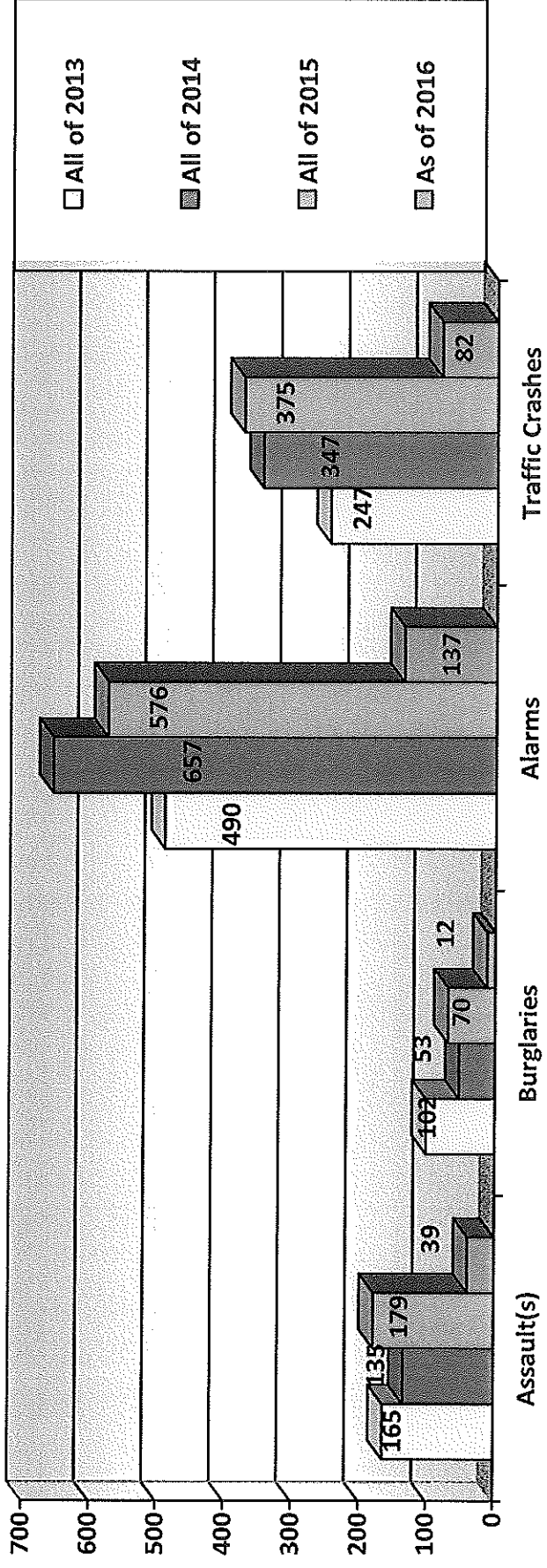
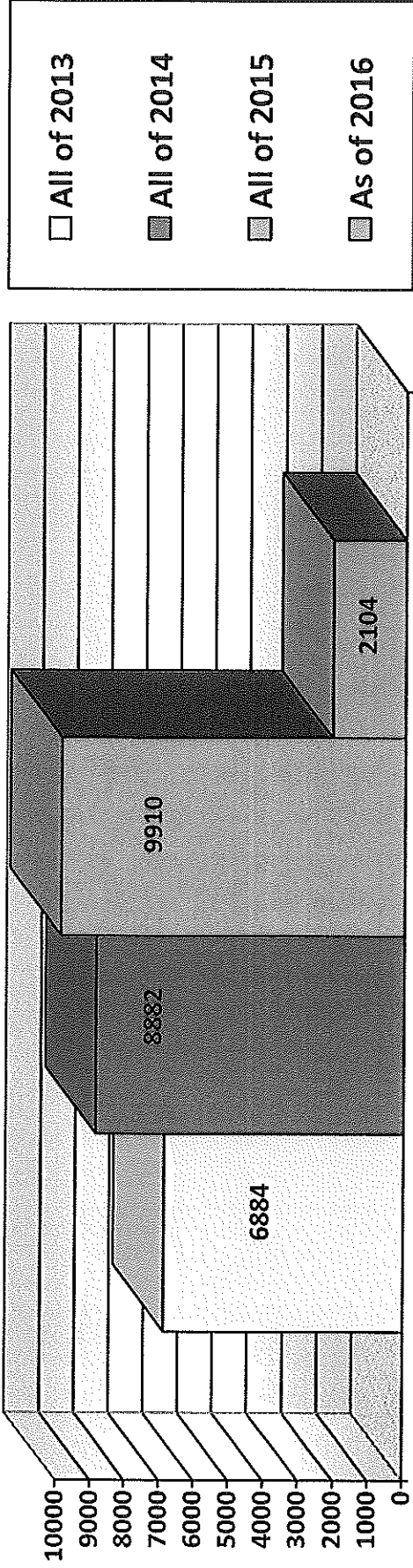

January, February, March, 2016

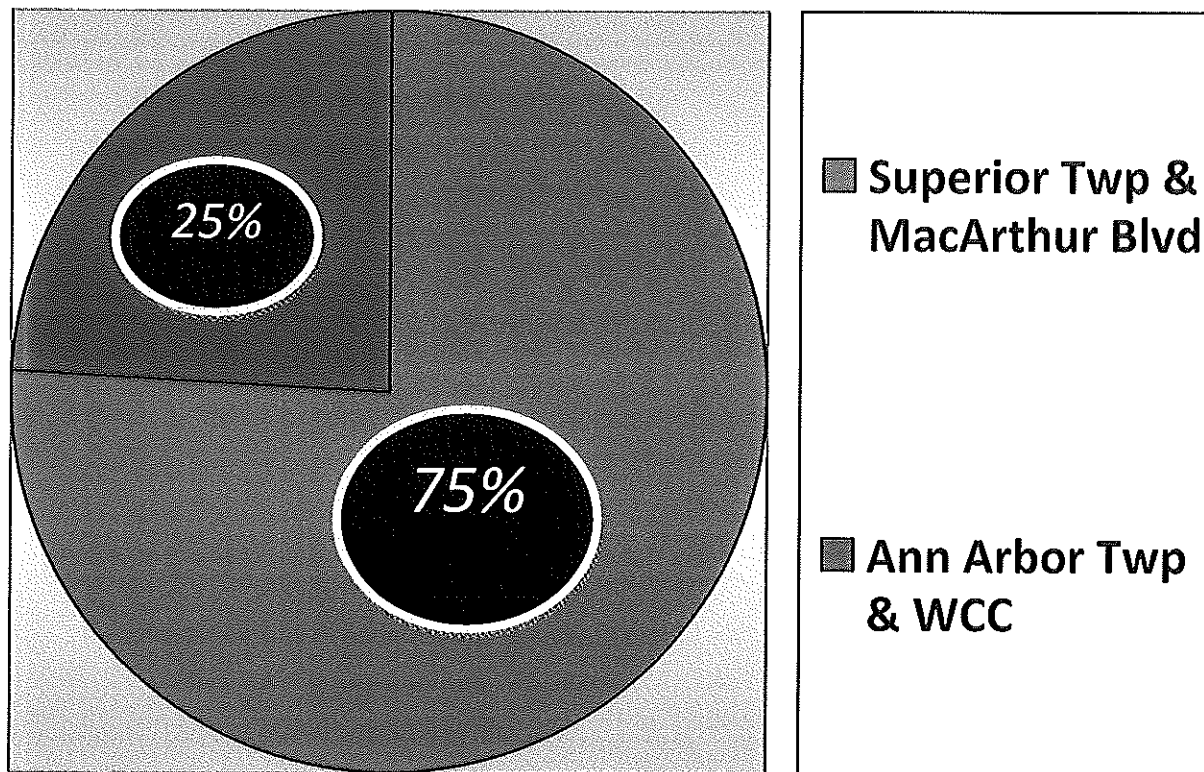

Superior Twp & MacArthur Blvd Total time =
208,653 Minutes /3477 Hrs 55 Min

Ann Arbor Twp & WCC Total Time =
63,425 Minutes /1057 Hrs 08 Min



Washtenaw County Sheriff's Activity Log

04/05/2016

Activity Log Area Summary Report

12:03 PM

Area: Superior Twp.

Date Range: 3/1/2016 - 3/31/2016

CSO/ACO/Support Staff Log	Total Administrative Duty:	9 for a total of	1095 minutes
	Total Follow Up:	15 for a total of	905 minutes
	Total Proactive Patrol:	23 for a total of	1045 minutes
	Total Service Request:	6 for a total of	240 minutes
	Total # of Activities:	53 for a total of	3285 minutes
Deputy Log	Total Administrative Duty:	375 for a total of	9982 minutes
	Total Briefing:	183 for a total of	3400 minutes
	Total Court (Regular Time):	1 for a total of	30 minutes
	Total Court (Overtime):	5 for a total of	870 minutes
	Total Community Relations:	41 for a total of	1220 minutes
	Total Court Off-Duty:	3 for a total of	480 minutes
	Total Deputy Join Shift:	17 for a total of	0 minutes
	Total Deputy Left Shift:	18 for a total of	0 minutes
	Total Follow Up:	115 for a total of	4885 minutes
	Total Out of Service:	54 for a total of	65 minutes
	Total Property Check:	250 for a total of	5255 minutes
	Total Proactive Patrol:	604 for a total of	14883 minutes
	Total Special Detail:	19 for a total of	670 minutes
	Total Selective Enforcement:	169 for a total of	4400 minutes
	Total Self-Initiated Activity:	21 for a total of	1405 minutes
	Total SM:	20 for a total of	705 minutes
	Total Service Request:	290 for a total of	13987 minutes
	Total Service Request Assist:	87 for a total of	2810 minutes
	Total Training:	11 for a total of	1260 minutes
	Total Traffic Stop:	142 for a total of	2535 minutes
	Total Other:	2 for a total of	70 minutes
Total # of Activities:	2427 for a total of	68912 minutes	
Detective Log	Total Administrative Duty:	4 for a total of	115 minutes
	Total Court (Regular Time):	1 for a total of	180 minutes
	Total Follow Up:	14 for a total of	1740 minutes
	Total Proactive Patrol:	7 for a total of	90 minutes
	Total Self-Initiated Activity:	1 for a total of	135 minutes
	Total Service Request:	3 for a total of	100 minutes
	Total Service Request Assist:	1 for a total of	20 minutes
Total # of Activities:	31 for a total of	2380 minutes	

General Fund Patrol	Total Community Relations:	1 for a total of	15 minutes	
	Total Follow Up:	1 for a total of	45 minutes	
	Total Out of Service:	1 for a total of	15 minutes	
	Total Proactive Patrol:	1 for a total of	10 minutes	
	Total SM:	1 for a total of	15 minutes	
	Total Service Request Assist:	3 for a total of	195 minutes	
	Total Traffic Stop:	1 for a total of	10 minutes	
	Total # of Activities:	9 for a total of	305 minutes	
	Secondary Road Patrol Log	Total Administrative Duty:	2 for a total of	30 minutes
		Total Proactive Patrol:	4 for a total of	90 minutes
Total Selective Enforcement:		1 for a total of	25 minutes	
Total Service Request Assist:		1 for a total of	50 minutes	
Total Traffic Stop:		2 for a total of	30 minutes	
Total # of Activities:		10 for a total of	225 minutes	
Supervisor Log	Total Administrative Duty:	163 for a total of	8125 minutes	
	Total Briefing:	24 for a total of	475 minutes	
	Total Court (Regular Time):	2 for a total of	225 minutes	
	Total Court (Overtime):	1 for a total of	30 minutes	
	Total Community Relations:	1 for a total of	105 minutes	
	Total Out of Service:	10 for a total of	0 minutes	
	Total Property Check:	16 for a total of	1165 minutes	
	Total Proactive Patrol:	20 for a total of	260 minutes	
	Total Selective Enforcement:	1 for a total of	95 minutes	
	Total Self-Initiated Activity:	2 for a total of	45 minutes	
	Total Service Request:	3 for a total of	65 minutes	
	Total Service Request Assist:	12 for a total of	545 minutes	
	Total Traffic Stop:	1 for a total of	20 minutes	
	Total Other:	2 for a total of	105 minutes	
	Total # of Activities:	258 for a total of	11260 minutes	
Total Superior Twp.:	2788 for a total of	86367 minutes (1439 hours 27 minutes)		



Washtenaw County Sheriff's Activity Log

Out of Area Report (Sorted by Date/Time, then Log ID)

4/11/2016 10:12 AM

Assignment Area: Superior Twp/Ann Arbor Twp

3/1/2016 - 3/31/2016

Log #	Deputy ID / Name	Date/Time	Minutes
566708	832 HANKAMP, JEFFREY LAMAR	3/01/16 1:20	25
Type:	Service Requests	Location: HEWITT/ELLSWORTH	Area: Ypsilanti Twp.
Comments:	TOT Twp. units		
566708	832 HANKAMP, JEFFREY LAMAR	3/01/16 6:40	25
Type:	Service Request Assist	Location: 1424 RIDGE	Area: Ypsilanti Twp.
Comments:	TOT F16		
567183	1050 ROSS, JEREMY DAVID	3/03/16 8:20	20
Type:	Service Requests	Location: 124 ALLEN	Area: Ypsilanti Twp.
Comments:	back up 721 per 623/cancelled enroute		
567326	832 HANKAMP, JEFFREY LAMAR	3/04/16 0:30	45
Type:	Service Request Assist	Location: CONCORD	Area: Ypsilanti Twp.
Comments:	ASSIST YPSI TWP/ SGT. HUNT		
567466	1918 PELTIER, SHANE C	3/04/16 18:30	120
Type:	Service Request Assist	Location: 2724 PEACHCREST ST	Area: Ypsilanti Twp.
Comments:	DISP: ASSIST 709 PER 631 / TRANSPORT FEMALE ARREST TO WCJ - TOT JAIL STAFF		
567524	958 LOSEY, ROBERT MICHAEL	3/05/16 14:55	65
Type:	Service Request Assist	Location: 1135 LEXINGTON PARKWAY	Area: Ypsilanti Twp.
Comments:	IN PROGRESS, SEARCH, TWO SUBJECTS IN CUSTODY, TOT DYER		
567529	1810 CARTER, ANDREW N	3/05/16 15:00	45
Type:	Service Request Assist	Location: 1572 FOLEY AVE	Area: Ypsilanti Twp.
Comments:	DISP: PER 638 / BACK-UP 701 / EDP / SECURE / TOT HVA		
567576	1763 GEBAUER, JOEL J	3/05/16 23:00	35
Type:	Service Request Assist	Location: 1439 ANDREA STREET	Area: Ypsilanti Twp.
Comments:	Assist Dep. Traskos Per 628. B&E Suspects in 1439 Andrea Street		
567721	2097 WARD, BRIAN D	3/07/16 4:20	40
Type:	Service Request Assist	Location: 685 W. CLARK RD	Area: Ypsilanti Twp.
Comments:	ASSIST WITH EDP		
567792	1810 CARTER, ANDREW N	3/07/16 18:15	30
Type:	Service Request Assist	Location: 501 HOLMES RD	Area: Ypsilanti Twp.
Comments:	DISP: PER 622 / HELP ID SUSPECTS - BILLY COX / ALVIN HARVEY JR / CEDDY SIMS / ID'S CONFIRMED		
568048	832 HANKAMP, JEFFREY LAMAR	3/09/16 5:30	150
Type:	Service Requests	Location: 2201 HOGBACK	Area: County Facilities
Comments:	16-17957		
568082	351 CROVA, JOSEPH MARIO	3/09/16 10:30	90
Type:	Service Requests	Location: 829 E MICHIGAN	Area: Ypsilanti Twp.
Comments:	disp: assit HVA with a edp ride with the to the hospital to avoid using force		
568255	832 HANKAMP, JEFFREY LAMAR	3/10/16 2:15	45
Type:	Service Request Assist	Location: WOODLAWN	Area: Ypsilanti Twp.
Comments:	TOT 719		
568718	1780 SMITH, JESSE N	3/12/16 21:40	30
Type:	Service Request Assist	Location: 6240 VALLEY FIELD	Area: Salem Twp.
Comments:	cancelled upon arrival-pennington approved		
568780	1050 ROSS, JEREMY DAVID	3/13/16 9:20	30
Type:	Service Requests	Location: 51451 E EIGHT MILE	Area: Salem Twp.
Comments:	back up 760 per 630/secure		

568905	351 CROVA, JOSEPH MARIO	Date/Time: 3/14/16	13:30	Minutes: 30
Type:	Service Requests	Location: CLARK RIDGE	Area: Ypsilanti Twp.	
Comments:	disp: warrant arrest handed by ypsi twp			
568921	267 STANTON, ROBERT DAVID	Date/Time: 3/14/16	13:50	Minutes: 10
Type:	Service Requests	Location: CLARK/RIDGE	Area: Ypsilanti Twp.	
Comments:	back ypsi units			
568933	1810 CARTER, ANDREW N	Date/Time: 3/14/16	16:50	Minutes: 40
Type:	Service Request Assist	Location: 1510 HOLMES RD	Area: Ypsilanti Twp.	
Comments:	DISP: PER 632 / BACK-UP YPSI TWP DEPS / HEROIN OD / SECURE - TOT HVA			
569031	832 HANKAMP, JEFFREY LAMAR	Date/Time: 3/14/16	23:30	Minutes: 45
Type:	Service Request Assist	Location: 714 OSWEGO	Area: Ypsilanti Twp.	
Comments:	ASSIST AT SHOOTING SCENE/ PER SGT. MAHALICK			
569016	1780 SMITH, JESSE N	Date/Time: 3/14/16	23:40	Minutes: 245
Type:	Service Request Assist	Location: 714 OSWEGO	Area: Ypsilanti Twp.	
Comments:	scene security/report written-sgt mahalick approved			
569004	1763 GEBAUER, JOEL J	Date/Time: 3/14/16	23:44	Minutes: 136
Type:	Service Request Assist	Location: 714 OSWEGO	Area: Ypsilanti Twp.	
Comments:	DISP: ASSIST OTHER UNITS FOR SHOOTING.			
569462	1050 ROSS, JEREMY DAVID	Date/Time: 3/17/16	8:40	Minutes: 20
Type:	Service Requests	Location: 6295 JOY	Area: Salem Twp.	
Comments:	back up MSP ref suicide per 623/cancelled			
569501	1918 PELTIER, SHANE C	Date/Time: 3/17/16	17:50	Minutes: 30
Type:	Traffic Stop	Location:	Area: Ypsilanti Twp.	
Comments:	RFS: INVALID PLATE			
569612	832 HANKAMP, JEFFREY LAMAR	Date/Time: 3/18/16	2:30	Minutes: 30
Type:	Service Request Assist	Location: GATE/BY PASS	Area: Ypsilanti Twp.	
Comments:	ASSIST REF SHOTS FIRED WEST WILLOW/ SGT. HUNT			
569931	2096 MORSY, AHMED M	Date/Time: 3/20/16	0:30	Minutes: 5
Type:	Service Request Assist	Location: 2420 E ELLSWORTH	Area: Ypsilanti Twp.	
Comments:	DENIED APPROVAL BY SGT HUNT AND TWP CARS SENT			
571052	1802 MCGRADY, PATRICK T	Date/Time: 3/27/16	1:35	Minutes: 40
Type:	Service Request Assist	Location: 2720 WASHTENAW	Area: Ypsilanti Twp.	
Comments:	assist ypt units w disorderly at hookah lounge			
571075	1763 GEBAUER, JOEL J	Date/Time: 3/27/16	1:35	Minutes: 20
Type:	Service Request Assist	Location: 2720 WASHTENAW AVE	Area: Ypsilanti Twp.	
Comments:	ASSISTED YPSI TWP UNITS PER 628/ UNKNOWN DISORDERLY/ POSSIBLE MAN WITH A GUN			
571067	2140 HALL, MICHAEL S	Date/Time: 3/27/16	1:40	Minutes: 15
Type:	Service Request Assist	Location: 2720 WASHTENAW AVE	Area: Ypsilanti Twp.	
Comments:	ASSIST YPSI DEPS WITH DISORDERLY AT HOOKAH LOUNGE PER 628			
571204	1763 GEBAUER, JOEL J	Date/Time: 3/28/16	1:55	Minutes: 25
Type:	Service Request Assist	Location: 727 OSWEGO ST	Area: Ypsilanti Twp.	
Comments:	ASSIST YPSI TWP UNITS PER 628			
571234	1780 SMITH, JESSE N	Date/Time: 3/28/16	2:00	Minutes: 30
Type:	Service Request Assist	Location: 727 OSWEGO	Area: Ypsilanti Twp.	
Comments:	assist ypsi unit with b/e in progress/mahalick approved			
571349	991 CAMPBELL, JOHN WILLIAM	Date/Time: 3/28/16	16:00	Minutes: 60
Type:	Special Detail	Location:	Area: Ypsilanti Twp.	
Comments:	LATE ARREST REF TRAFFIC DETAIL DDACT			
571525	832 HANKAMP, JEFFREY LAMAR	Date/Time: 3/30/16	1:40	Minutes: 65
Type:	Service Request Assist	Location: DELAWARE/PEABODY	Area: Ypsilanti Twp.	
Comments:	TOT 716			

Total Minutes: 1641

(27 hours 21 minutes)

County Facilities:	1	trips totaling	150	minutes
Salem Twp.:	3	trips totaling	80	minutes
Ypsilanti Twp.:	28	trips totaling	1411	minutes



Washtenaw County Sheriff's Activity Log

Assist Into Unassigned Area Report (Sorted by Date/Time, then Log ID)

04/05/2016

Assistance Into Area: Superior Twp.

12:00 AM

3/1/2016 - 3/31/2016

Log #	Deputy ID / Name	Date/Time	Type
567510	1137 RISHA, MATTHEW	3/5/2016 3:25 PM	Service Request Assist
Location: 8796 MACARTHUR BLVD		Minutes: 25	Assignment Area: Salem Twp
Comments: Disp: It was a civil matter		Assist Into: MacArthur Blvd Contract	
567876	1749 CRATSENBURG, JOHN A	3/8/2016 1:10 AM	Service Request Assist
Location: 9328 MAC ARTHUR BLVD		Minutes: 30	Assignment Area: Ypsilanti Twp
Comments: ASSIST SUPERIOR UNITS TRY AND LOCATE SUBJECT THAT STABBED THEMSELVES AND FLED THE AREA 629		Assist Into: MacArthur Blvd Contract	
567873	586 HAUSE, KEVIN PATRICK	3/8/2016 1:10 AM	Service Request Assist
Location: 9328 MACARTHUR BLVD		Minutes: 25	Assignment Area: Ypsilanti Twp
Comments: ASSISTED SUPR. TWP UNTIS / OK PER SGT. FOX		Assist Into: MacArthur Blvd Contract	
568042	2172 HOGAN II, MICHAEL D	3/9/2016 5:30 AM	Service Request Assist
Location: 2201 HOGBACK		Minutes: 75	Assignment Area: Ypsilanti Twp
Comments: ASSIST 767 PER 639		Assist Into: Superior Twp.	
568755	1781 CORRIE, PAUL E	3/13/2016 4:25 AM	Service Request Assist
Location: MACARTHUR/WIARD		Minutes: 100	Assignment Area: Ypsilanti Twp
Comments: ASSIST 767 W/OVI/CCW ARREST, PER 628		Assist Into: Superior Twp.	
568870	797 KITTLE, BRIAN SCOTT	3/14/2016 4:10 AM	Service Request Assist
Location: 1515 RIDGE		Minutes: 30	Assignment Area: Ypsilanti Twp
Comments: Assisted Deputy Hankamp with strong arm robbery. Cleared by Sgt. Mahalick		Assist Into: Superior Twp.	
569572	2170 TRASKOS, RICHARD T	3/17/2016 7:10 PM	Service Request Assist
Location: CLARK / PROSPECT		Minutes: 5	Assignment Area: Ypsilanti Twp
Comments: HELD DOWN TRAFFIC CRASH FOR SUPERIOR UNITS / APPROVED SGT. EGELER		Assist Into: Superior Twp.	
569673	336 PASTERNAK JR, ROBERT J	3/18/2016 7:55 AM	Service Requests
Location: HRD / FOSTER RD BRIDGE		Minutes: 20	Assignment Area: Scio
Comments: hrd / foster rd bridge: (3) semi trucks blocking rdwy / trucks turned around and sent back to wagner rd / out of area activity approved by sgt.cook.		Assist Into: Ann Arbor Twp.	
569791	1750 ROY, JAMES M	3/19/2016 2:45 AM	Service Request Assist
Location: 1534 DAWN		Minutes: 70	Assignment Area: Ypsilanti Twp
Comments: Assist Sup. Twp. per Sgt. Hunt		Assist Into: Superior Twp.	
569802	1123 WALLACE, SAMUEL D	3/19/2016 2:55 AM	Service Request Assist
Location: 1534 DAWN AVE		Minutes: 45	Assignment Area: Ypsilanti Twp
Comments: Dispo: Backed Superior Unit w/Threats call. Approved by Sgt. Hunt.		Assist Into: Superior Twp.	
569938	1750 ROY, JAMES M	3/20/2016 7:15 AM	Service Requests
Location: 10250 GEDDES		Minutes: 20	Assignment Area: Ypsilanti Twp
Comments: ASSIST WITH ALARM PER PAT BELL		Assist Into: Superior Twp.	



Washtenaw County Sheriff's Activity Log

Assist Into Unassigned Area Report (Sorted by Date/Time, then Log ID)

04/05/2016

Assistance Into Area: Superior Twp.

12:00 AM

3/1/2016 - 3/31/2016

Log #	Deputy ID / Name	Date/Time	Type
570765	1750 ROY, JAMES M	3/25/2016 5:20 AM	Service Request Assist
Location: 1574 STRATFORD		Minutes: 65	Assignment Area: Ypsilanti Twp
Comments: DISP: ASSIST SUPERIOR UNITS, TRANSPORT SUBEJCT TO DB - PER Assist Into: Superior Twp. SGT. 629			
570763	797 KITTLE, BRIAN SCOTT	3/25/2016 5:25 AM	Service Requests
Location: 1574 STRATFORD CT		Minutes: 25	Assignment Area: Ypsilanti Twp
Comments: Cleared to assist by Sgt, Fox Assist Into: Superior Twp.			
570763	797 KITTLE, BRIAN SCOTT	3/25/2016 6:05 AM	Service Requests
Location: 8866 MACARTHUR BLVD		Minutes: 35	Assignment Area: Ypsilanti Twp
Comments: Cleared to assist by Sgt. Fox Assist Into: MacArthur Blvd Contract			
570783	353 HOWELL, BRIAN LEE	3/25/2016 6:05 AM	Service Requests
Location: 8966		Minutes: 95	Assignment Area: Ypsilanti Twp
Comments: TRANSPORT FOR 767, APPROVED BY 729 Assist Into: MacArthur Blvd Contract			
570906	1050 ROSS, JEREMY DAVID	3/25/2016 5:40 PM	Service Requests
Location: MACARTHUR/HARRIS		Minutes: 40	Assignment Area: Ypsilanti Twp
Comments: assist w/ search of woods per 632 Assist Into: Superior Twp.			
571228	797 KITTLE, BRIAN SCOTT	3/28/2016 4:35 AM	Self-Initiated Activity
Location: PROSPECT/VREELAND		Minutes: 70	Assignment Area: Ypsilanti Twp
Comments: Assist with security while on sobriety, impound and breath test cleared to assist by Sgt, Mahalick Assist Into: Superior Twp.			

Total Minutes: 775 (12 hours 55 minutes)

Salem Twp	1	trip totaling	25 minutes
Scio	1	trip totaling	20 minutes
Ypsilanti Twp	15	trips totaling	730 minutes
Total:	17	trips totaling	775 minutes

Date: March 29, 2016

To: Superior Township Board of Trustees

From: Parks and Recreation Commission

Re: Pedestrian Crossing to and from Firemans Park

Please place on the April 18, 2016 Superior Township Board of Trustees meeting agenda consideration for a pedestrian crosswalk west of Harris Rd., south to north across MacArthur Blvd. leading to Firemans Park.. Also consider placement of "Slow, Children at Play" signs along MacArthur in the vicinity of the crosswalk.

These considerations are of importance to the safety of the children who will cross MacArthur into the park where the new play structures will soon be erected.

If you would like additional information please contact Juan Bradford, Administrator at the Parks and Recreation office.

INTEROFFICE MEMORANDUM

TO: KEN SCHWARTZ, TOWNSHIP SUPERVISOR
FROM: JUAN BRADFORD, PARKS & RECREATION ADMINISTRATOR
SUBJECT: BUILDING HEALTHY COMMUNITIES GRANT UPDATE
DATE: APRIL 11, 2016
CC: TOWNSHIP TRUSTEES

Superior Township Parks & Recreation Department was selected by Michigan Recreation & Parks Association (mParks) along with ten other communities in the state to participate in a pilot grant program called Building Healthy Communities (BHC). BHC is a grant program offered and funded by the Michigan Department of Health and Human Services (MDHHS) as part of its "Getting to the Heart of the Matter" initiative. The purpose of BHC is to create policy, system and environmental changes that support physical activity and healthy eating.

The BHC program will provide funding to mParks to implement and evaluate evidenced based programming in the ten select communities. Each community will receive up to \$24,000.00 for park improvements, up to \$10,000.00 for staffing to supervise required BHC programming, and up to \$500.00 for program materials. All funding will be reimbursed by mParks to each community after submittal of invoices. The grant timeline is very short and must be completed by September 30, 2016. This includes the hiring & training of staff, implementation of programming, completion of capital improvement projects, and reporting.

Fireman's Park was chosen as our location due to the lower income level of the neighborhood and the need to provide healthy opportunities for those residents at no cost to them. We have posted surveys at both the Danbury and Sycamore apartment complexes as well as the Superior library branch asking the residents to provide input into the upgrades they would like to see at the park. To date a majority of the surveys have indicated the desire for a play structure. RFP's have been solicited to reflect this.

The BHC programming part of the grant requires us to run two programs this summer. For the youths we will be running "Come out and Play" (COAP) which follows curriculum outlined by mParks and focuses on fitness though 60 minutes of fun physical activity. For the adults we will be implementing the Arthritis Foundations "Walk with Ease" (WWE). Both programs will consist of three 6 week sessions and will be free to all participants. The target dates for programming is May 30th through September 30th for WWE and June 20th through September 9th for COAP.

We have posted employment opportunities for 4 seasonal positions related to the grant at both the Danbury and Sycamore apartment complexes, the Superior library branch, and on the township's website. These employees will be completely paid for through the BHC grant.

At the conclusion of both programs we will be able to record data relating to the number of participants, attendance trends, steps taken, miles walked, park visits, and participants health objectives. We will also have provided a long term improvement to the surrounding neighborhood as well as set the stage for residents to adopt healthy lifestyle habits.

A third facet to the BHC grant is *optional* and involves adopting a smoke/tobacco free park policy. I personally feel that this is a great step for the township and look forward to discussing if further with both the Park Commission and the Township Board.

If you would like any additional information please feel free to contact me at your convenience.

Michigan Department of Health & Human Services
Cardiovascular Health, Nutrition & Physical Activity Section
Getting to the Heart of the Matter Project

Building Healthy Communities –Parks Grant (BHC)

Part I: General Guidelines and Information

A. Overview and Purpose:

Everyone deserves access to resources that support healthy lifestyles where they live, learn, work and play. The physical environments and local policies in our communities can play an influential role in health outcomes. Improving community environments and policies to ensure all residents can reach their highest health potential is an important piece of preventing chronic diseases.

Building Healthy Communities (BHC) is a grant program offered by the Michigan Department of Health and Human Services (MDHHS), Cardiovascular Health, Nutrition and Physical Activity Section (CVHNPA) in the Division of Chronic Disease and Injury Control (DCDIC). The purpose of BHC is to create policy, system and environment changes supportive of physical activity and healthy eating. The program aims to reduce cardiovascular disease, obesity, and other chronic conditions among disparate populations.

For fiscal year 2015-2016, the BHC program will provide funding to Michigan Recreation and Park Association (MPRA) to implement and evaluate evidence-based interventions to increase access to physical activity opportunities via parks as part of the new MDHHS DCDIC initiative "Getting to the Heart of the Matter in Michigan."

The priority objectives, strategies, and interventions of the 2015/2016 BHC program are provided in the table on page three. The program aligns with national strategies, the Michigan 4 x 4 Health and Wellness Initiative, and also includes recommendations of The Guide to Community Preventive Services and objectives of Healthy People 2020 as outlined below:

- Create social and physical environments that promote good health;
- Promote quality of life, healthy development, and healthy behaviors across the life span;
- Achieve health equity and the elimination of health disparities.

2015-2016 GHM -Building Healthy Communities Priority Interventions for Physical Activity

Physical Activity Goal: Increase the percentage of individuals in Michigan achieving adequate physical activity.

Priority Objective: Increase the number of policies and environmental changes paired with information outreach, in parks, to create safe, appealing places for physical activity.

Priority Strategies:	Priority Interventions:	Activities*
Enhance parks/greenspace and amenities.	<ol style="list-style-type: none"> 1. Creating or enhancing walking paths 2. Installing play/exercise equipment 3. Improving access and attraction to parks within ½ mile radius 4. Implementing a smoke-free park policy (1 Policy required in each region) 	<ol style="list-style-type: none"> 1. Installing a walking loop around a playground or on perimeter of park 2. Installing equipment/playscapes such as jungle gyms, adult exercise equipment, active play equipment 3. Installing signage, safety amenities, safe access amenities (physical infrastructure), and bike racks/fix it stations, addressing curb appeal 4. Adopt a smoke free park policy and install signage
Build awareness of new policies and environmental changes through informational outreach.	<ol style="list-style-type: none"> 1. Implement health and fitness programs. 2. Marketing/advertising policy, environmental changes, and health programs. 	<ol style="list-style-type: none"> 1. Plan, implement, and evaluate a walking club/program: 1 Adult and 1 Youth program required.¹ 2. Marketing/advertising the parks, offering incentives to visit

* Examples only – in no way do the listed examples represent all possible activities

1. Adult walking club will use the Arthritis Foundation Walking With Ease program. Youth program will use the MRPA Come Out and Play Curriculum.

Strategies	Resources
Enhance parks/greenspace and amenities.	<ul style="list-style-type: none"> • <u>CDC Strategies to Increase Physical Activity in Communities</u> • <u>CDC Establishing a Community-Based Walking Program</u> • <u>Creation of Enhanced Access to Places for Physical Activity</u> • <u>MIDHHS Evaluation Toolkit for Smoke-Free Policies</u>

**Building Health Communities – Getting to the Heart of the Matter
A Grant funded by the Michigan Department of Health and Human Services**

Program Synopsis

The Building Health Communities program will implement and evaluate evidence-based interventions to increase access to physical activity opportunities via parks as part of the new MDHHS DCDC initiative “Getting to the Heart of the Matter in Michigan.” The program aligns with national strategies, the Michigan 4 x 4 Health and Wellness Initiative, and also includes recommendations of The Guide to Community Preventive Services and objectives of Healthy People 2020 as outlined below:

- Create social and physical environments that promote good health;
- Promote quality of life, healthy development, and healthy behaviors across the life span;
- Achieve health equity and the elimination of health disparities.

The overall goal is to increase the number of policies and environmental changes paired with information outreach in parks and to create safe, appealing places for physical activity.

mParks will work with ten communities, five from Washtenaw County and five from Antrim, Charlevoix, Emmet, and Otsego Counties to :

- Review GIS maps of green spaces in the region and collect data from the County Health Assessments/BFRRS data regarding obesity, physical activity demographic data, data pertaining to people living ½ mile radius from parks and other pertinent data. mParks staff will complete research as part of the grant funding.
- Work with selected communities to implement the Arthritis Foundation’s “*Walking with Ease*” program for adults and seniors; and mParks “*Come Out and Play*” curriculum for youth. All costs, including staffing, for implementation of the programs are included in the grant funding. There is some funding available for each community to purchase enhancements items to make parks more accessible and desirable for users.
- Provide tools and resources for communities interested in implementing tobacco free policies.
- Connect with Federally Qualified Health Centers and other health systems and providers in each region to introduce the programs and parks.
- Collect, analyze and summarize pre and post testing and data from program participants. mParks will provide all resources for the evaluation process.

INTEROFFICE MEMORANDUM

TO: KEN SCHWARTZ, TOWNSHIP SUPERVISOR
FROM: JUAN BRADFORD, PARKS & RECREATION ADMINISTRATOR
SUBJECT: KELLY MILLER CIRCUS UPDATE
DATE: APRIL 14, 2016
CC: TOWNSHIP TRUSTIES

As you are aware the Parks & Recreation Commission has previously approved entering into an agreement with the Kelly Miller Circus to host a circus in Superior Township on August 13, 2016. I thought it appropriate to provide the Township Trustees with some information associated with the circus and allow any questions to be answered.

I have included with this memorandum an informational brochure from the Kelly Miller Circus which outlines what will be provided by the circus and what will be provided by the sponsor (Superior Township). Also included is information regarding the care of the animals that travel with the circus.

I will be attending the April 18, 2016 Regular Meeting of the Township Board in case there are additional questions that either you or the other trustees may have.

If you would like me to provide any further information prior to the meeting please let me know.

Attachments:

Kelly Miller Circus brochure

Introduction (to animal care)

Care of Animals



INTRODUCTION

We at The Kelly Miller Circus are happy and proud to include animals in our performance. In doing so, we also understand the duty and responsibility to care for and transport these animals in the proper manner. We are dedicated to their well being and we consider them an integral part of the Kelly Miller Circus family.

There are obviously people who disagree with us. Sometimes it is just a well meaning, concerned citizen who wants to make sure we *do* take care of our animals properly and sometimes there are groups from animal activist organizations that will stage a protest.

We proudly live and work in the United States where people are allowed freedom of speech and have the right to express their opinions, even if we don't agree with them. The animal activist groups are known for radical views and the opposition to animals performing in circuses. That is their opinion. They are also known for using discriminatory language when it comes to accusing "*all circuses*" of negligent behavior when it comes to the care, well being, and transportation of circus animals. These groups are not beyond making false accusations about an animal trainer or a circus in order to gain publicity and further their cause.

It is not our agenda to attack animal activists with counterproductive examples of their behavior or tactics when it comes to our encounters with them or other circuses. It is our duty to inform you and educate you to the care, transportation, and husbandry of all our animal performers, so you will not be intimidated by them and led to believe accusations that are not true.

We hope the following information will help address some of your concerns and allow you to be able to enjoy the circus performance and make your circus day a GREAT experience!



Care of Animals

- ❖ The Kelly Miller Circus is governed by the United States Department of Agriculture (USDA). There are rules and regulations regarding the care, housing, and transporting of our animals that we must adhere to at all times. The USDA conducts scheduled and surprise inspections during our traveling year and even during our off season, when we are at our winter quarters home. The Kelly Miller Circus is also a member of the USDA Exhibitors Association and The Outdoor Amusement Business Association (OABA).

- ❖ All the animals that are traveling and working with the Kelly Miller Circus are seen by a veterinarian every 30 days for checkups and copies of the most current health certificate will always be available to you, either from our Home Office or Road Office. There are 10 people employed with the circus strictly for the animals' care, comfort, and oversight. The animal caretakers have an extensive network of veterinarians in every state we travel and are in constant communication with our primary veterinarian, DR. Larry Salyer of Hugo, Oklahoma.

- ❖ The routing of our circus from town to town is designed in consideration of our sponsors but more importantly, for the comfort of our animals, as well. We travel in the very early morning hours which are normally the coolest part of the day and also to avoid traffic delays so the animals spend the minimum amount of time possible in their transportation vehicles.

- ❖ The public has access to view the animals everyday, 7 days a week. We welcome everyone to see our animals and ask questions of our trainers. They are happy to answer any questions you or the public might have.



WHO WE ARE: America's Premier Family Circus founded in 1938. Our permanent home is in Hugo, Oklahoma where we are a member of the Chamber of Commerce. We exhibit in over 220 cities and towns each year from the nation's heartland to the Atlantic - - from the Gulf to the borders of Canada.

When you sign a contract with Kelly-Miller to exhibit in your Community, it is a sign of trust that we take very seriously.

OUR PLEDGE TO YOU...

- 1st. We are a traveling community of families entertaining families. Leaving a positive impression with the public is extremely important to us.
- 2nd. Our business dealings with the public and our sponsors must be above reproach.
- 3rd. Always give the public their money's worth.
- 4th. **CLEAN!** Everything from the employees to trucks, animals and even the grounds must be clean. We work hard to leave the circus grounds so that you can't tell that the circus has been there.
- 5th. We buy locally. The circus boosts your local economy by purchasing supplies through your merchants.

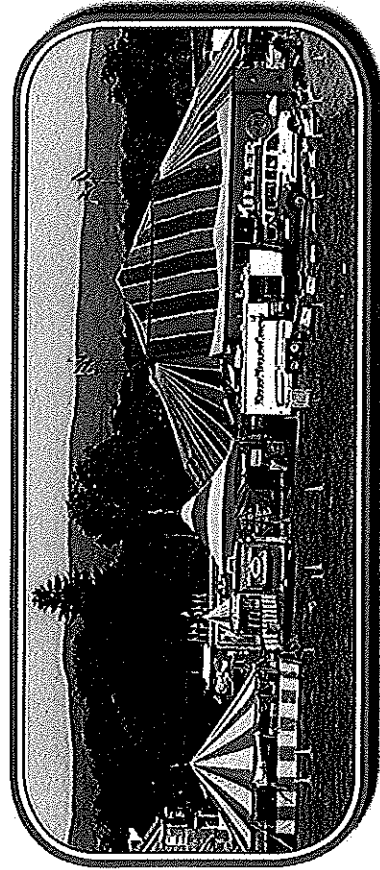

**A Fund Raising Project With a Proven Plan
For Your Organization**

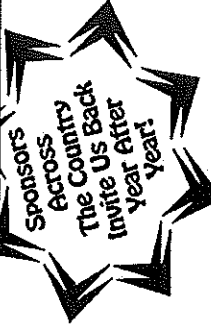

KELLY MILLER CIRCUS

2581 E. 2070 Road • P.O. Box 829
Hugo, Oklahoma 74743
580-326-9229 • Fax 580-326-5530
bigtop@kellymillercircus.com

www.kellymillercircus.com

TICKET PRICES

General Admission (Day of the Show)	Adult:	\$16.00
	Child:	\$8.00
Sponsor Tickets (Before Day of Show)	Adult:	\$12.00
	Child:	\$6.00
Special Children's Tickets		\$6.00

(Children: 2 years through 11 years inclusive)

SPONSOR PROFITS

- * 20% of 1st 200 advance sale adult tickets
- * 40% of advance sale adult tickets - after the 1st 200
- * 25% of all advance sale children's tickets sold
- * 25% of all special children's tickets sold
- * 10% of all circus tickets sold by circus on circus day
- * **BONUS:** Additional 5% of all circus tickets sold by circus on circus day IF sponsor sells over 500 advance adult tickets.

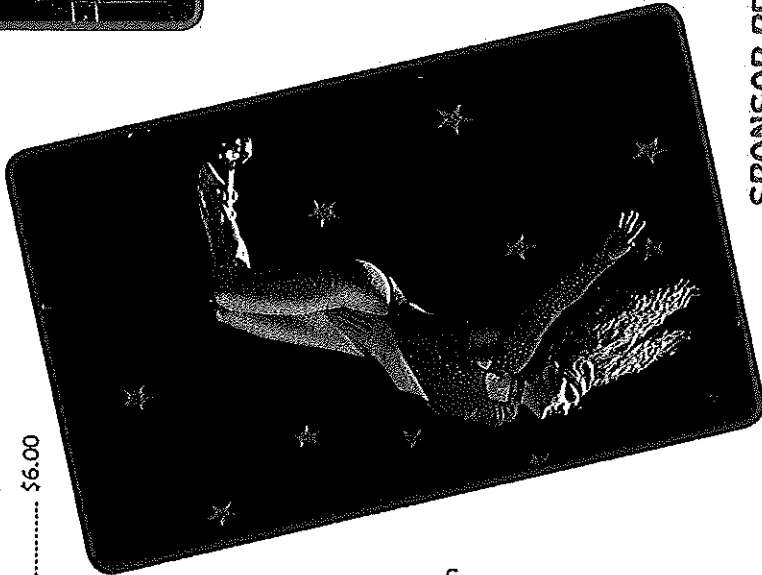
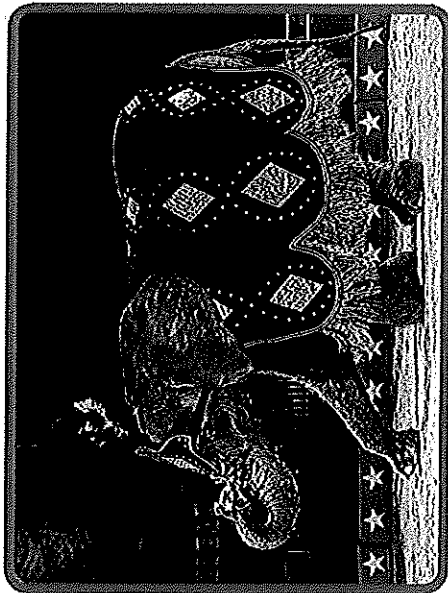

CIRCUS PROVIDES THE FOLLOWING:

- A home office team of professionals providing full support throughout your circus adventure, your "personal trainers".
- \$1,000,000 public liability insurance indemnifying sponsor, landowner and all operations of the circus.
- Advance telemarketing personnel to sell special children's tickets for sponsor.
- Two complete circus performances with all the magic of a real old time tented circus.
- All required electricity (we provide our own generators).
- Tents, seats and equipment.
- Personnel necessary to erect tents, provide performances and clean premises.
- 1000 adult & 1000 children's advance tickets and tickets sold on circus day.
- 100 posters & 50 table tents to be placed by sponsor.
- Will place up to six 4' x 6' banners in the tent and our ringmaster will draw attention to them. Sponsor contacts businesses for these banners and retains all revenue from them.
- Online ticket sales as an advance ticket outlet.

SPONSOR PROVIDES THE FOLLOWING:

- Suitable show grounds approximately 350' x 350' accessible for all weather conditions.
- Permits and/or licenses as required by law (local, county or State), if necessary.
- Access to water (either a spigot or fire hydrant) on or near show grounds.
- Police and Fire protection if required by local authority.
- Containers for trash/manure. Circus will pick up all trash, but Sponsor is responsible for removing containers.
- Contracting fee of \$290 to be paid at signing of contract.

David Phillips

From: Kellie McIvor <KMclvor@byRedwood.com>
Sent: Friday, April 15, 2016 12:02 PM
To: David Phillips
Cc: Ken Schwartz; Richard Batt
Subject: Sutton Ridge - April 18 Meeting

Hi, Dave—

Redwood respectfully requests that the matter of the Trustee's approval of the Sutton Ridge project be tabled until the May 16 meeting.

If you have any questions/concerns, please do not hesitate to contact me.

Thanks, Dave, and have a great weekend—

Kellie

Kellie McIvor
Vice President of Development

Redwood Living, Inc.
23775 Commerce Park, Suite 7
Beachwood, OH 44122
c: 216.254.8425
kmcivor@byRedwood.com
www.byRedwood.com

Redwood Living is on a mission



[click here to discover why](#)

This email and any files transmitted with it are confidential and intended solely for the use of the individual or entity to whom they are addressed. If you have received this email in error, please notify the sender or system manager immediately. In addition, this email neither constitutes an agreement to conduct transactions by electronic means nor creates a legally binding contract or enforceable obligation in the absence of a fully signed written contract. Contract terms contained in this email are subject to approval by Redwood Communities Group, LLC and its affiliates, and are not binding until Redwood Communities Group, LLC provides such approval in writing.



PARKS & RECREATION
INTEROFFICE MEMO

DATE: April 4, 2016
TO: Board of Trustees
FROM: Parks Commission
RE: Commission Vacancy Recommendation

At the regular meeting of the Superior Township Park Commission held on March 28, 2016, the Commission interviewed candidates interested in filling the vacancy on the Commission created by the very unfortunate passing of longtime Commission Chair-Person Jan Berry.

Two candidates were interviewed.

Paula Jefferson

Diana Rivis

Park Commissioners asked each applicant about their objectives for park development, park maintenance, and for recreation programming.

We found both Ms. Jefferson and Ms. Rivis to be very impressive candidates, both extremely qualified to fill the seat.

It was moved by Sandi Lopez and supported by Martha Kern-Boprie to recommend to the Township Board that Paula Jefferson be appointed to the open position on the Parks Commission for the remainder of the term ending 11/20/16. The motion carried by a vote of three "Yes" to two "No" with one commissioner absent.

We thank both Ms. Jefferson and Ms. Rivis for coming forward. Superior Township is fortunate to have such talented and enthusiastic residents who are willing to contribute toward the betterment of the Township!

PAULA JEFFERSON

1585 Harvest Lane
Ypsilanti, MI 48198
pjeffuller@gmail.com
734-657-6836

2-28-15

Superior Township
Ypsilanti, MI

Re: Parks Commission Position

I have lived in this township all my life with the exception of one school year spent attending college in Chicago. My community is important to me and for years I've thought about getting involved in its political process. In the past I have been critical of some of the decisions made in the community, but I believe without a working knowledge of what went into making those decisions my critiques could be unfounded. Additionally, when I believe my critiques are valid I should be willing to put some skin in the game and take responsibility and help make some of those decisions.

My work experience as an administrative assistant and business analyst in the transportation industry has given me skills that will be useful for this position. As a member of the Learning and Development department my job was to support the training division of operations. I worked with multiple people across departments as well as external vendors to arrange travel, hotel and transportation logistics. I created and maintained daily training completion reports for our training initiatives using PeopleSoft, Brainshark, SharePoint, Cornerstone LMS and Excel. I was responsible for purchasing, expenditure requests and reconciling outstanding expenses in Concur.

I would be honored to serve my community as a member of the Parks Commission. Thank you for taking the time to consider my letter of interest and I look forward to hearing from you in the near future.

Sincerely,



Paula Jefferson

March 4, 2016

Ken Schwartz, Supervisor
Superior Charter Township
3040 N. Prospect Rd.
Superior Township, MI 48198

Re: Appointment to Parks Commission

Dear Supervisor Schwartz,

The purpose of this letter is to inform the Township of my interest in the vacant Parks Commissioner position. I've been a Township resident for over thirty years and have a Bachelor's Degree of Business Administration. I also have a long history of serving the Township and its residents in the following ways:

- I was a Superior Township Park Commissioner from 1996 through 2002 and served as both Chair and Vice-Chair during my tenure.
- From 2002 through 2013, I was the Office Manager for the Superior Township Utility Department.
- Since my retirement from the Utility Department, I've been a volunteer Election Inspector for Superior Township.

I believe that my diverse background and familiarity with the Township would provide me with the ability to contribute to the Commission within a very short period of time. I thank you, in advance, for your consideration.

Best regards,

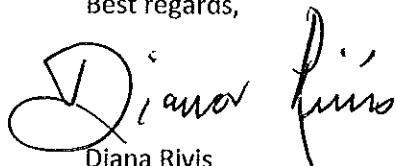
A handwritten signature in cursive script that reads "Diana Ravis". The signature is written in black ink and is positioned to the right of the typed name.

Diana Ravis
1636 Sheffield Drive

Memorandum

To: Superior Township Board of Trustees
From: Keith Lockie
Date: April 18, 2016
Re: Zero Turn Mower

Background

The Utility Department is responsible for the mowing of the following Township properties (approximately 13 acres, total):

1. Maintenance Facility
2. Bromley Access Road
3. Woodside Access Road
4. Geddes Booster Station
5. LeForge Booster Station
6. Section 36 Lift Station
7. DWSD Property (Ridge @ Geddes)

Current Equipment

The Department currently has a 2006 Toro Groundmaster, whose original cost was \$17,000. We have no backup mower, which could cause a problem if the Toro is in for repair during the growing season.

Recommended Action

Included, are four quotes, ranging from a low of \$13,577.59 (Toro) to a high of \$18,618.60 (John Deere). All current mowers for Utility and Parks are Toros and we have overall had good luck with them. Therefore, I recommend purchasing the Toro 7000 Mower from Commercial Lawnmower of Livonia, Michigan at a cost of \$13,577.59.

Funds are available in our Capital Reserves for this expenditure.

/attachments

**SUPERIOR CHARTER TOWNSHIP BOARD
RESOLUTION**

**A RESOLUTION AUTHORIZING THE ADMINISTRATIVE STAFF TO
EXECUTE THE PROPOSED JUDGMENT PERTAINING TO BROOKSIDE II
LAND, L.L.C. vs. SUPERIOR TOWNSHIP**

RESOLUTION 2016-06

APRIL 19, 2016

WHEREAS, Brookside Land II L.L.C. owns the Prospect Pointe East Subdivision which is zoned R-4; and

WHEREAS, the R-4 zoning district mandates that the ground floor coverage (GFC) shall be no greater than 25% of the total lot. Plaintiff has requested Superior Township to issue building permits for construction on certain lots that would exceed the GFC by more than 25% but less than 26%; and,

WHEREAS, the Superior Township building department denied building permits for structures which exceeds 25% GFC; and,

WHEREAS, Plaintiff filed a law suit challenging the application of the zoning ordinance because the difference between the GFC and the estimated GFC for the lots in question are *de minimis*; and,

WHEREAS, both parties seek to amicably settle their difference in this matter and have arrived at a solution favorable to the parties.

NOW THEREFORE BE IT RESOLVED that the Superior Charter Township Board of Trustees authorizes the administrative staff to execute the consent judgment as presented with exhibits.

STATE OF MICHIGAN

WASHTENAW COUNTY CIRCUIT COURT

BROOKSIDE II LAND, L.L.C.,
limited liability company

Case No. 16-
Hon.

CZ

Plaintiff,

vs.

CHARTER TOWNSHIP OF SUPERIOR,
a Michigan Municipal Corporation,

Defendant.

David Hansma (P71056)
Duncan P. Ogilvie (P56628)
Seyburn Kahn
2000 Town Center, Suite 1500
Southfield, MI 48075
(248) 353-7620
mcohn@seyburn.com
Attorneys for Plaintiff

Frederick Lucas (P29074)
Lucas & Baker
7577 US Highway 12, Suite A
Onsted, Michigan 49265
(517) 467-4000
lucas@lucaslawpc.com
Attorney for Defendant

CONSENT JUDGMENT

At a session of said Court, held in the City of Ann Arbor,
County of Washtenaw, State of Michigan on

PRESENT: HON. _____
CIRCUIT COURT JUDGE

This Consent Judgment is based upon the stipulation and consent of the parties, by and through their respective attorneys, based upon the following facts and representations:

1. Plaintiff, Brookside II Land, L.L.C. (the "Plaintiff"), is marketing and selling homes within the residential site condominium units within Prospect Pointe condominium

located in the Charter Township of Superior, which are legally described on *Exhibit A* attached hereto (the “Lots”).

2. The Defendant, Charter Township of Superior (the “Township”), is a municipal corporation organized and existing under Act 359, PA 1947, as amended, MCL 42.1 *et. seq.*, located in Washtenaw County, Michigan.

3. The Lots are located with the R-4 Zoning District under the Zoning Ordinance of Superior Charter Township (“Zoning Ordinance”).

4. The Zoning Ordinance provides that the maximum ground floor coverage (“GFC”) for homes constructed within the R-4 Zoning District is twenty five percent (25%) of the total area of the applicable lot.

5. The estimated GFC’s for the Lots exceed twenty five percent (25%) by a very small margin as identified on *Exhibit B* attached hereto.

6. The difference between the maximum GFC under the Zoning Ordinance and the estimated GFC’s for the Lots is *de minimis*.

7. Plaintiff has requested that the Township be required to issue building permits for the Lots, notwithstanding the *de minimis* difference between the maximum GFC provided in the Zoning Ordinance and the actual GFC’s for the Lots.

8. The Township will not issue building permits to Plaintiff or its affiliated builder to construct homes within the Lots because the estimated GFC’s exceed twenty five percent (25%).

9. On March _____, 2016, Plaintiff filed suit against the Township seeking the right to obtain building permits for the Lots, notwithstanding the *de minimis* difference between the maximum GFC provided in the Zoning Ordinance and the actual GFC’s for the Lots.

10. The parties now desire to settle this lawsuit in accordance with the terms and conditions of this Consent Judgment in order to avoid further costs and expenses and the uncertainty of a trial, and to resolve their disputes relative to this matter without any admission of liability.

11. The parties agree not to appeal from or otherwise contest: (a) the authority or jurisdiction of this Court to enter this Consent Judgment; and/or, (b) any of this Consent Judgment's terms or conditions.

12. The parties agree, and the Court by entering this Consent Judgment finds, that the Consent Judgment's terms and conditions are fair, reasonable and consistent with the public interest and applicable laws.

THEREFORE, without taking any testimony and without this Consent Judgment constituting an admission or evidence of any of the Complaint's allegations, and upon consent from the Township and the Plaintiff, IT IS HEREBY ORDERED AND ADJUDGED that:

I. ISSUANCE OF BUILDING PERMITS

Building permits for the Lots shown on Exhibit B shall not be denied by the Township on the basis that the GFC's for the Lots exceed the maximum GFC provided in the Zoning Ordinance, provided that the GFC for each Lot is not greater than that shown on Exhibit B.

II. ENFORCEMENT OF CONSENT JUDGMENT

The parties agree that the terms and conditions of this Consent Judgment will be enforceable in this Court. This Consent Judgment is effective immediately upon approval by the Court and the parties acknowledge that it is not subject to appeal.

In the event of a proceeding to enforce any term or provision of this Consent Judgment, the parties may seek to recover costs and reasonable attorney fees in addition to any other applicable and available relief.

III. MUTUAL RELEASE FROM LIABILITY

Plaintiff, for itself, its officers, owners, shareholders, members, employees, representatives, agents, independent contractors, consultants, attorneys, successors and assigns, and the Defendant, Township, for its employees, elected and appointed officials, boards, commissions, independent contractors, agents, representatives, consultants, attorneys, successors and assigns, mutually release and forever discharge each other of and from any and all claims, demands, liabilities, actions, causes of action, suits, debts, judgments, executions, damages, costs, expenses, fees and rights of whatever nature in law, equity or otherwise, which now exist or which may subsequently accrue by reason of any act, events or facts arising out of or related to this lawsuit and existing on the date of this Consent Judgment, whether known or unknown on that date. This mutual release shall not bar claims brought to enforce the provisions of this Consent Judgment.

IV. ADDITIONAL PROVISIONS

A. **Good Faith.** The parties and their respective successors and assigns shall treat each other in good faith and shall neither take any action which is contrary to nor interferes with the spirit of this Consent Judgment.

B. **Recordation.** This Consent Judgment shall be recorded with the Washtenaw County Register of Deeds, and the covenants contained herein are declared to be covenants running with the land and all portions or divisions thereof, and the obligations, duties and rights herein shall be binding on the respective heirs, successors, grantees, transferees, lessees, and assigns of the parties, and the Washtenaw County Register of Deeds is ordered to record a true copy of this Consent Judgment in the land records of Washtenaw County.

C. **Authority.** By their execution of this Consent Judgment, Plaintiff and the Township warrant that they have the authority to execute this Consent Judgment and bind their

respective entities, successors and assigns to its terms and conditions. The parties represent to the Court that they have read this Consent Judgment, have discussed it with counsel, understand the terms and conditions thereof, and agree to be bound by the Consent Judgment.

D. **Conflicts.** To the extent that this Consent Judgment conflicts with any current or future Township ordinance, policy, regulation or code, the terms of this Consent Judgment shall control. However, to the extent that the Consent Judgment is silent on issues regulated by the Township ordinances, policies, regulations and/or codes, then the Township ordinances, policies, regulations and/or codes shall control to the extent that they are not inconsistent with this Consent Judgment. Plaintiff shall be required to comply with any applicable rules and regulations of other governmental entities which have jurisdiction. Plaintiff shall adhere to all Building Codes, regulatory ordinances and the Construction Standards of the Township and other regulatory agency's requirements in effect at the time of development of the Property, except to the extent inconsistent with this Consent Judgment.

E. **Amendment.** The terms of this Consent Judgment and Exhibits may be amended, changed or modified but only by written agreement executed by the parties hereto and later approved and ordered by this Court. Either party may initiate a proposed Amendment to this Consent Judgment and the parties shall negotiate in good faith, pursuant to Paragraph A above, in an effort to arrive at a mutually agreeable amendment if possible.

F. **Severability.** Each restriction, sentence, part, phrase and/or clause is intended to be severable and in the event that any restriction, sentence, part, phrase and/or clause is for any reason held void, it shall not affect the validity of the remainder of this Consent Judgment.

G. **Clerical Errors.** Any clerical errors or mistakes in document or exhibit descriptions contained in this Consent Judgment may be corrected by the parties, and all parties

agree to cooperate in making such corrections in order to effectuate the spirit and intent of the parties in entering into this Consent Judgment.

H. **Judgment and Exhibits.** This Consent Judgment is hereby deemed to include all exhibits attached hereto, said exhibits being incorporated herein and made a part hereof as fully and to the same extent as if the contents of the exhibits were set out in their entirety in the body of this Consent Judgment. All references to this Consent Judgment are deemed to be a reference to the body of this Consent Judgment and to the exhibits set forth and permitted in the Consent Judgment.

I. **Dismissal of Claims.** Except as provided by this Consent Judgment, all claims asserted in this lawsuit, including all claims for money damages, attorney fees and costs, are merged into this Consent Judgment and forever barred. Each party shall be responsible for their own attorney fees, costs and expenses.

J. **Continuing Jurisdiction.** This Court retains continuing jurisdiction to assure enforcement and compliance with the terms of this Consent Judgment, including the reasonableness of any requested Amendments to the Consent Judgment brought before the Court. The Court also retains jurisdiction to approve major amendments to this Consent Judgment, interpret and enforce the terms and conditions of this Consent Judgment, resolve any dispute, and reconcile any differences between the parties that may arise relating to performance of the terms of this Consent Judgment and to take any action necessary or appropriate for the Consent Judgment's construction or implementation.

K. **Force Majeure.** In the event either party to this Consent Judgment is delayed or prevented from performance of any act required hereunder by reason of strikes, lockouts, labor troubles, inability to procure materials, failure of power, restrictive governmental laws or

regulations, riots, insurrection, war or acts of nature not the fault of such party, then the performance of such act shall be excused for the period of the delay.

L. **No Precedent.** The terms of this Consent Judgment are limited to the facts, circumstances and parties involved in this case, shall have no binding or precedential effect on the Township other than for this dispute and further, shall not confer any rights or remedies upon any third party other than the parties to this agreement and their respective successors and assigns.

M. **Successors and Assigns.** This Consent Judgment shall be binding upon, and inure to the benefit of, the parties hereto and their respective successors and assigns.

**THIS CONSENT JUDGMENT RESOLVES ALL PENDING CLAIMS AND
CLOSES THIS CASE.**

IT IS SO ORDERED.

Circuit Court Judge

Approved:

PLAINTIFF

BROOKSIDE II LAND, L.L.C,
A Michigan limited liability company

By: _____

Its: _____

STATE OF MICHIGAN)
COUNTY OF _____)

On this ____ day of _____, 2016, before me a notary public acting in _____ County, Michigan personally appeared _____, who being by me sworn, did say that he executed the foregoing instrument as his free act and deed.

_____, Notary Public
_____ County, State of Michigan
Acting In _____ County,
My Commission expires: _____

-and-

By: _____
DAVID HANSMA (P71056)
Counsel for Plaintiff

CHARTER TOWNSHIP OF SUPERIOR

By: _____

Its: _____

-and-

By: _____

Its: _____

STATE OF MICHIGAN)
COUNTY OF _____)

On this ___ day of _____, 2016 before me the subscriber, a Notary Public in and for said County, personally appeared _____ and _____, to me personally known, who being by me duly sworn did say that they are _____ and _____, in the Charter Township of Superior, a Michigan Municipal Corporation, and that the seal affixed to said instrument is the corporate seal of the Municipality, and that said instrument was signed and sealed in behalf of the Municipality, by authority of its governing body, and the signers hereto acknowledged said instrument to be the free act and deed of said Municipality.

_____, Notary Public
_____ County, State of Michigan
Acting In _____ County,
My Commission expires: _____

-and-

By: _____
Frederick Lucas
Counsel for Defendants

**This instrument was drafted by
and when recorded return to:**

MARK S. COHN
Seyburn Kahn, P.C.
2000 Town Center, Suite 1500
Southfield, Michigan 48075
(248) 353-7620

Exhibit A

Description of the Lots

Land situated in the Township of Superior, County of Washtenaw, State of Michigan, described as follows:

Units 1, 45-47, 55-58, 66-71, 77-80, 91-96, 105, 106, 108, 109, 113, 114, 121, and 122 of Prospect Pointe East Condominium, a Condominium according to the Master Deed Recorded in Liber 4507 page 881, Washtenaw County Records.

Exhibit B

List of GFC's for the Lots

Lot Number	% of Lot Coverage
1	25.72%
45	25.76%
46	25.74%
47	25.26%
55	25.79%
56	25.79%
57	25.79%
58	25.79%
67	25.79%
68	25.79%
69	25.79%
70	25.79%
71	25.79%
77	25.79%
78	25.79%
79	25.79%
80	25.79%
91	25.79%
92	25.79%
93	25.79%
94	25.79%
95	25.79%
96	25.79%
105	25.31%
106	25.79%
108	25.79%
109	25.79%
113	25.79%
114	25.79%
121	25.46%
122	25.38%

**SUPERIOR CHARTER TOWNSHIP
WASHTENAW COUNTY, MICHIGAN**

RESOLUTION NUMBER: 2016-07

DATE: APRIL 18, 2016

**A RESOLUTION FOR APPROVAL FOR ENTERING INTO A STREET-SIDE
MAINTENANCE AGREEMENT WITH MR. BUTLER FOR THE OAKBROOK AND
WASHINGTON SQUARE SUBDIVISION COMMON AREAS**

WHEREAS, Superior Charter Township is a Michigan municipal corporation that provides public services to residents of Superior Charter Township, and

WHEREAS, a Special Assessment District was created to provide funding for street-side maintenance in the Oakbrook and Washington Square subdivisions located in the Township, which includes cutting the grass and other maintenance of the common areas, and

WHEREAS, the Township Board has the responsibility to approve, execute and administer agreements to provide for such street-side maintenance, and

WHEREAS, Mr. Charles Swanson, who passed away in February 2016, had completed the side-street maintenance since 2001, and

WHEREAS, Mr. Robert Lee Butler assisted Mr. Swanson with the side-street maintenance and also has worked as an independent contractor for the Township for many years, and

WHEREAS, the Township has been extremely satisfied with the performance of Mr. Butler;

NOW, THEREFORE BE IT RESOLVED: that the Superior Township Board approves the Agreement for 2016 with Mr. Robert Lee Butler for side-street maintenance in an amount not to exceed \$18,684.00 and authorizes the Township Supervisor to sign the Agreement, and that the cost of this agreement is to be taken from the Side Street Maintenance Fund, G.L. Account No. 220.

AGREEMENT BETWEEN
CHARTER TOWNSHIP OF SUPERIOR
AND
ROBERT LEE BUTLER

This agreement made this _____ day of April 2016 by and between the Charter Township of Superior, hereafter referred to as the Township, and Robert Lee Butler, hereafter referred to as Contractor. The Township desires to secure the services of a Contractor for street side maintenance in specified areas within the Township and Contractor desires to provide such services.

Now, therefore, in consideration of the promises and covenants hereinafter contained, the parties hereto mutually agree as follows:

1. The relationship of the Contractor to the Township is and shall continue to be that of an independent contractor. The Township shall provide no benefits of any kind including but not limited to worker's compensation, pension contribution, unemployment benefits or other rights or liabilities arising out of or related to this contract; neither shall an employee/employer relationship shall arise to either party as a result of the performance of this contract. The Contractor has signed the Townships Independent Contractor Release Agreement.
2. The Contractor shall maintain General Liability Insurance in the amount of at least \$1,000,000 naming the Charter Township of Superior as an additional insured and provide the clerk with a copy within (10) days of signing the Contract.
3. The Contractor shall maintain the following street sides for the 2016 Summer Season including lawn cutting and trimming weekly, brush and tree trimming as needed, and liter removal along street sides as needed. See listing below:
 - a. Berkshire, east of Prospect south side; from entrance to Lakeview Estates @ 2/10 mile – 12 feet wide.
 - b. North side of Berkshire starting at Wilshire then east to Prospect (not including the yard of the occupied home on Berkshire). East side to Prospect starting at Berkshire then north about 1/10 of a mile to a wooded area. Maintain this as required by item #3 above.
 - c. MacArthur Blvd – north side from fireman's park to Stamford @ 800 ft. strip – 12 feet wide.
 - d. MacArthur Blvd – both sides from Stamford to Clark @ 6/10 strip – 42 feet wide from street to fences.
 - e. MacArthur Court at one acre.
 - f. Heather Island – MacArthur @ 500 feet.

- g. Nottingham Island – from Clark Road @ 500 feet.
 - h. Clark Drive Island – from Clark road @ 100 feet.
 - i. MacArthur Drive east along Clark Road to Clark Drive Island – 5/10 mile 36 feet strip to fence.
 - j. MacArthur Blvd. and Oakbrook entrance to island tree trimming and clean up.
4. Clark Road west starting @ MacArthur west to the church on the north side of Clark @ 3/10 mile – 36 feet wide from road to sidewalk.
 5. Stamford Road east side starting at or near Dawn. Forty two feet to private fences, then along Stamford Road for 5/10 of a mile east to the north property line of Township property.
 6. The Township shall pay the Contractor \$17,684.00 and \$1,000.00 for the added work on Stamford in the 2016 season. The Contractor will bill the township bi-weekly starting approximately April 20, 2016 through November 15, 2016.
 7. This contract may be terminated with a ten (10) day notice by either party.

By: _____
Robert Lee Bulter
Contractor

Date: _____

By: _____
Kenneth Schwartz
Township Supervisor

Date: _____



Attachment A

RELEASE AGREEMENT

This agreement is made by and between Robert Lee Butler, 8457 Berkshire, Ypsilanti, MI 48198 (Vendor) and Superior Charter Township, 3040 North Prospect Road, Ypsilanti, MI 48198 on _____, 20 _____.

1.0 Acknowledgments

1.1 Superior Charter Township will issue to Vendor an Acceptance of Proposal under which the Vendor will perform certain services on and/or deliver certain goods to the premises of Superior Charter Township, in consideration for which Superior Charter Township has promised to pay to Vendor the sum of \$17,684.00 plus an additional \$1,000.00 for added work along Stamford.

1.2 Vendor is aware of the nature of Superior Charter Township's work, purpose, and premises and all hazards to the Vendor, its employees, agents, or subcontractors arising therefrom and out of the nature of the work to be performed by the Vendor on Superior Charter Township's premises.

1.3 It is the intention of the Vendor and Superior Charter Township that Superior Charter Township, its officers, agents, employees, attorneys, property owners and residents shall not be liable or in any way responsible for damage, loss, or expense resulting to the Vendor, its employees, agents, subcontractors, or any other party, due to accidents, mishaps or injuries, either to person or property, of any kind, arising from any cause whatsoever, except such damage, loss, or expense arising from intentional misconduct by Superior Charter Township, occurring during or in relation to the Vendor's performance of the work specified in the accepted proposal. This provision is not intended and shall not be construed to waive, diminish or abrogate immunity from liability granted by law to Superior Charter Township, its officers, agents, employees, attorneys, property owners and residents.

2.0 Agreement

In consideration of Superior Charter Township's agreement to retain and hire the Vendor, and Superior Charter Township's promise to pay the Vendor as specified and as specified in said proposals, Superior Charter Township and the Vendor agree as follows:

2.1 Vendor will comply with and will cause its employees, agents and subcontractors to comply with all Superior Charter Township safety rules and all rules and standards of applicable state and federal occupational safety and health acts while on Superior Charter Township's premises.

2.2 Vendor expressly releases Superior Charter Township, its officers, agents, employees, attorneys, property owners and residents from all liability or responsibility of any kind arising from the death or injury to persons or the destruction of property resulting from actions or inactions of Vendor or its employees, agents, or subcontractors while performing under said work specified in accepted Proposal. This Release includes, but is not limited to, falls from scaffolding, ladders, catwalks, beams or other high places; mishaps involving equipment; injuries from electric shock; and, injuries from defects in equipment, instruments or devices.

2.3 Vendor and all subcontractors/independent contractors shall carry liability insurance and workers' compensation insurance as required by law and shall deliver evidence of that insurance to Superior Charter Township on demand.

2.4 If Vender is a sole proprietor they shall carry liability insurance as required by law and shall deliver evidence of that insurance to Superior Charter Township on demand.

2.5 Vendor agrees to indemnify Superior Charter Township and its officers, agents, employees, and community from any claim, damage or liability which Vendor, its employees, agents, subcontractors, or any other party may sustain due to the death or injury to persons or the destruction of property from actions or inactions of Vendor or its employees, agents, or subcontractors arising out of Vendor's or their performance of work specified in the accepted Proposal. Vendor agrees to reimburse Superior Charter Township any costs incurred as a result of Vendor's failure to carry or provide proof of required or adequate insurance. Such costs include, but are not limited to, actual damages, claims for damages, insurance premiums imposed by Superior Charter Township's carrier or underwriter and attorney fees resulting from Vendor's breach.

2.6 Vendors will use all reasonable means, including E-Verify or any successor program implemented by the Federal Department of Homeland Security and the Social Security Administration when hiring their employees in order to ensure that all of their employees are legally documented workers.

2.7 This Release Agreement is supplemental to said accepted Proposal, which is made a part of this Release.

2.8 The vendor hereby certifies they are not an Iran-based business as defined in MCL 129.312.

In witness to and in agreement, the parties execute this Release Agreement as of the date written above.

DATED: _____ VENDOR

By: _____

Its: Sole Proprietor

DATED: _____ SUPERIOR CHARTER TOWNSHIP

By: _____

Its: _____

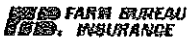

CERTIFICATE OF INSURANCE

Scan Code
CERT

FARM BUREAU MUTUAL INSURANCE COMPANY OF MICHIGAN
 FARM BUREAU GENERAL INSURANCE COMPANY OF MICHIGAN
 Lansing, Michigan 48909

AMENDED

Name and Address of Certificate Holder:

**SUPERIOR TOWNSHIP
3040 N PROSPECT
YPSILANTI MI 48198**

Named Insured and Address:

**ROBERT BUTLER
6457 BERKSHIRE
YPSILANTI MI 48198**

Issue Date: **04/13/2016**

This is to certify that the following policy(ies) of insurance has (have) been or will be issued by the Company to the Named Insured. This certificate is not a guarantee that the policy(ies) will remain in effect until its (their) stated expiration date. In the event of cancellation of any of the insurance policies before the expiration date, the Company will endeavor to mail notice of such cancellation to the Certificate Holder designated above at the Certificate Holder's last known address, but failure to mail such notice shall impose no obligation or liability of any kind upon the Company. This certificate is issued as a matter of information only and confers no rights upon the Certificate Holder. This certificate does not amend, extend, or alter the coverage afforded by the policy(ies) of insurance indicated below. The information conveyed in this Certificate of Insurance is only valid for the indicated policy periods. Certificates of Insurance for subsequent policy periods must be requested by the Certificate Holder.

Type of Insurance	Policy Number	Policy Period	Limits of Liability
Business Auto Liability • Specifically Described Autos (Symbol 7) <input type="checkbox"/> Hired Auto (Symbol 8) <input type="checkbox"/> Non-Owned Auto (Symbol 9)		Eff. Exp.	Combined Single Limit Each Accident \$
Worker's Disability Compensation		Eff. Exp.	Coverage A - Statutory Coverage B - Bodily Injury by Accident \$ Each Accident (Employer's Liab.) Bodily Injury by Disease \$ Each Employee Bodily Injury by Disease \$ Policy Limit
Comprehensive General Liability or Commercial Package <input checked="" type="checkbox"/> Including <input type="checkbox"/> Excluding Products-Completed Operations <input type="checkbox"/> Personal Injury and Advertising Injury Liability Coverage Is Included <input checked="" type="checkbox"/> Hired Auto <input checked="" type="checkbox"/> Non-Owned Auto <input type="checkbox"/> CERTIFICATE HOLDER is an Additional Insured <input type="checkbox"/> Excluding:	S-3039641	Eff. 04/11/2016 Exp. 04/11/2017	Each Occurrence \$ 1,000,000 Products Aggregate \$ 2,000,000 General Aggregate \$ 2,000,000 Medical Payments Limit \$ 5,000
Owners and Contractors Protective Liability		Eff. Exp.	Each Occurrence \$ General Aggregate \$
Products - Completed Operations Liability		Eff. Exp.	Each Occurrence \$ Products Aggregate \$
Umbrella Liability		Eff. Exp.	Limit \$
Farmowners Liability Including Products Business Pursuits <input type="checkbox"/> Excluded <input type="checkbox"/> Included		Eff. Exp.	Limit \$ Type: Describe:
Other		Eff. Exp.	

Patrick Conklin

Digitally signed by Patrick Conklin
 DN: cn=Patrick Conklin, o=Farm Bureau Insurance, ou,
 email=patrick.conklin@fbinsm.com, c=US
 Date: 2016.04.13 13:16:40 -0400

X

Authorized Signature

3965

Agent Number

(734) 971-2114

Agent Phone Number

FAX COVER SHEET

TO

COMPANY

FAXNUMBER 17344844883

FROM PatrickConklin

DATE 2016-04-13 17:21:19 GMT

RE Robert Butler certificate

COVER MESSAGE

Connie Simpson / Office Manager
SCHNEIDER/CONKLIN/LOZANO AGENCY
Farm Bureau Insurance
2730 Carpenter Rd, Ste 1
Ann Arbor MI 48108
P: 734-971-2114 | F: 734-971-2117
Visit our website:
www.FarmBureauInsurance.com<<http://www.farmbureauinsurance.com/>>

Confidentiality Note: This email and any attachments are confidential and may be protected by legal privilege. If you are not the intended recipient, be aware that this disclosure, copying, distributing, or use of this email or any attachments is prohibited. If you have received this email in error, please notify me by returning it to me and delete this copy from your system. Thank you for your cooperation

**SUPERIOR CHARTER TOWNSHIP BOARD
RESOLUTION**

RESOLUTION 2016-08

APRIL 18, 2016

**A RESOLUTION ESTABLISHING A SUMMER SCHEDULE FOR THE
SUPERIOR TOWNSHIP OFFICE STAFF**

WHEREAS, the Superior Township office staff working at the township hall has requested the Board to review and approve a summer work schedule taking effect on May 2, 2016 and concluding on September 2, 2016; and,

WHEREAS, the proposed summer schedule will not affect the delivery of services to the residents of the township; and is currently practiced by the utility and parks department with no detriment to residential services.

NOW THEREFORE BE IT RESOLVED that the Superior Charter Township Board of Trustees adopts the proposed summer schedule as attached and directs the administrative staff to post the schedule at the township hall and to publish the schedule on the township's website.

MEMORANDUM

TO: Superior Township Board of Trustees
FROM: Richard Mayernik, Building/Zoning Official
RE: Farmers Market at Dixboro Village Green
DATE: April 7, 2016

R

A *Transient and Amusement Enterprises* application has been received from Dixboro Village Green, Inc., for the 2016 season of the Dixboro Farmers Market to be operated at Parcel J-10-18-260-001 (Village Green).

The action requested of the Township Board is that the Board “accept” the application after finding that “...activity will not adversely affect adjoining properties or adversely affect public health, safety, morals, or general welfare...”. The Township Board can accept applications subject to any conditions or limitations they find to be appropriate and may also require the submission of a performance guarantee.

Applications accepted by the Board require additional review prior to final approval. Non-profit activities (such as in this case) receive administrative review while all other uses require a public hearing before the Planning Commission and the issuance of a Conditional Use Permit.

Please find the following comments for the Board’s consideration:

1. The Farmers Market shall provide copies to the Township of any Washtenaw County Health Department of Michigan Department of Agriculture approvals required for any prepared food items.
2. Prior to the first Farm Market sale day, provide the Township a copy of the owner’s liability insurance policy as required.
3. Dixboro Village Green, Inc. shall contact the Superior Township Fire Chief and the Washtenaw County Sherriff’s Department in order to obtain comments and approvals prior to the first Farm Market sale day.

TRANSIENT AND AMUSEMENT ENTERPRISES ACTIVITY PERMIT APPLICATION

Request is hereby made for a permit to operate a Transient and Amusement Enterprise as permitted in Section 6.05 of the Superior Township Zoning Ordinance.

APPLICANT INFORMATION

Organization Name Dixboro Village Green, Inc. - d.b.a. Dixboro Farmers Market,
I.R.S.501(c) (3) Dixboro Artisan Market & Cars on the Green

Contact Person Tom Freeman (c/o Dixboro United Methodist Church)

Contact Address 5221 Church Road, Ann Arbor, MI 48105

Telephone (734) 216-6999 Fax _____ Email freemant@ewashkentaw.org

Is the property owned by the organization? YES **NO**

If "NO", what is the organization's interest in the property? Lessee

Name, address and telephone number of property owner(s):

Dixboro United Methodist Church
5221 Church Road, Ann Arbor, MI 48105 (734) 665-5632

DESCRIPTION OF THE ACTIVITY

Proposed activity (describe each separate activity) Dixboro Farmers Market - providing fresh locally grown food to the community; Dixboro Artisans Market - providing an outlet for local artists & crafters; Cars on the Green - a classic car show for community entertainment.

Date and time of activity May 20 - October 21, one day per week (Friday) 3:00 - 7:00 pm

Location of activity Dixboro Village Green

Staff person(s) in charge of activity Jason Gold, Market Manager

Describe staff supervision of activity The Market Manager, working under the supervision of the Dixboro Village Green, Inc. Board of Directors, will manage the activity with the support of community volunteers.

Permits required by other agencies _____

DESCRIPTION OF THE SITE

Size of activity site 1.6 acres Size of buildings (if any) n/a

Tax code number(s) of the property J- 10 - 18 - 260 - 001

Adjoining land uses: North church/residential South commercial/residential
East residential West commercial

Availability of bathroom, hygiene facilities. Please describe. restrooms are available for use in the church.

Clean-up and removal of waste. Please describe. Site clean-up is the responsibility of the Market Manager.

The following items are required as part of the Transient and Amusement Enterprises Use Permit Application:

1. A letter of authority, or power of attorney, in case the application is made by a person other than the actual owner of the property.

CHECK IF ATTACHED

2. A complete legal description of the premises (as stated on the deed or tax bills available in the Treasurer's Office).

CHECK IF ATTACHED

3. An accurate plot plan, drawn to scale, which indicates all access drives, buildings and other existing features of the site as well as all proposed features (parking, etc.) for the activity.

CHECK IF ATTACHED

4. A detailed description of the proposed activity.

CHECK IF ATTACHED

5. A copy of the property owner's liability insurance policy covering the proposed activity.

CHECK IF ATTACHED

APPLICANT

I hereby depose and say that all the statements in this application and statements contained in the documents and papers submitted herewith are true and correct.

Signature of Applicant: Jim A. Tu

Sworn to before me this 30 day of March 2016

My commission expires Anton Egel 3/30/16
(Notary Public, Washtenaw County, Michigan)

Signature of Property Owner (if other than applicant): Carl Johns

To be filled in by Township Clerk (or designated Township Officer/Personnel)

I hereby state that this petition was properly received and filed on _____ (date)

Signature of Clerk (or designee)

SUPERIOR CHARTER TOWNSHIP
3040 NORTH PROSPECT, YPSILANTI, MI 48198
TELEPHONE (734) 482-6099 FAX (734) 482-3842

Certificate of Zoning Compliance

This application must be accompanied by a site plan which is drawn to scale and contains the following information: 1) scale, date and north point. 2) location, shape and dimensions of the lot. 3) dimensioned location, outline and dimensions of all existing and proposed structures, and location and extent of uses not involving structures.

Address of Property: Parcel ID# J-10-18-260-001 (Village Green)

Applicant Name: Dixboro Village Green, Inc.

Address: 5221 Church Road

City, State, Zip Code: Ann Arbor, MI 48105

Phone Number: _____ Alternate Number: (734) 216-6999 (Tom Freeman cell#)

Provide a complete description of existing and intended uses of the property and structures, existing and proposed:

- *Dixboro Farmers Market - every Friday, May 20-Oct 21, from 3:00pm-7:00pm
- *Dixboro Artisan Market - last Friday of the month, May-Oct, from 3:00pm-7:00pm
- *Cars on the Green - classic car show, Friday, Sept. 16, from 3:00pm-7:00pm
- *Dixboro Farmers Market-Thanksgiving Market, Nov. 22, from 10:00am-2:00pm

The undersigned certifies that he/she is the owner or agent of the owner authorized to submit this application.

Jim A. [Signature]
Applicant Signature

March 30, 2016
Date

Township Use Only

Parcel Number: _____

Site Plan Number: _____

Parcel Zoning District: _____

Zoning Administrator: _____

Zoning Compliance Approved

Zoning Compliance Denied

Reason for Denial: _____

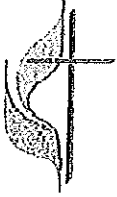

Dixboro United Methodist Church

5221 Church Road
Ann Arbor, Michigan 48105

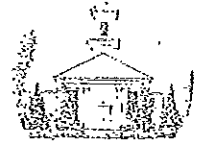

"People Helping People"

Lead Pastor: Rev. Tonya M. Arnesen
Email: dumc@dixborochurch.org

734-665-5632
www.dixborochurch.org

February 21, 2012

Richard J. Mayernik, C.B.O.
Building Zoning Official
Superior Charter Township
3040 North Prospect Road
Ypsilanti, MI 48198

This letter serves as authorization for the Dixboro Village Green, Inc., a private, non-profit 501 (c)3 corporation (pending) to submit a Transient and Amusement Enterprises Activity Permit Application for the purpose of operating a farmers market on the Dixboro Village Green. This authorization is extended under my authority as Chair of the Dixboro United Methodist Church Board of Trustees and on behalf of the Dixboro United Methodist Church Administrative Council, which acted on this issue at its meeting of January 19, 2012.

Sincerely,

Carl Johns, Chair
Board of Trustees
Dixboro United Methodist Church

Cc: Reverend Tonya Arnesen, Lead Pastor
Tom Little, Chair, DUMC Administrative Council

Dixboro Farmers Market

Purpose:

The Dixboro Farmers Market will be a community market, owned and operated by Dixboro Village Green, Inc., a private non-profit 501 (c) (3) corporation. The Dixboro Farmers Market will offer area residents access to locally grown fruits, vegetables and other farm products. Moreover, the market will foster a sense of community within the Village of Dixboro, creating a gathering place and supporting the interpersonal relationships, cooperation and engagement that are fundamental to community renewal.

Market Description:

The Dixboro Farmers Market will consist of an outdoor market located on the Village Green in the Village of Dixboro. The Farmers Market will operate one day per week (Friday) from 3:00 pm to 7:00 pm with the season running from May 20th through October 21st. The market will offer locally grown food – fruits, vegetables, baked goods, etc. – as well as other farm products. In addition, artisans will participate in the market on the last Friday of each month during the Farmers Market season, offering an outlet for local artists and crafters. And finally, a classic car show, known as “Cars on the Green”, will take place on September 16th as an event associated with the Farmers Market.

Vendor stalls will be arranged on the Village Green as shown on the accompanying site plan. It is anticipated there will be 25 – 30 vendors participating each week.

Parking for market patrons will be provided at the Dixboro United Methodist Church – located on the north side of Church Road and directly adjacent to the Farmers Market.

Restrooms for patrons of the market will be available within the Dixboro United Methodist Church, located directly adjacent to the Farmers Market.

A site plan, illustrating the layout of the Farmers Market, is attached as required.

PLYMOUTH ROAD

← classic car display →

← classic car display →

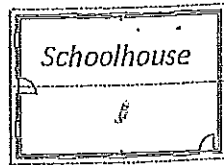

Market stalls

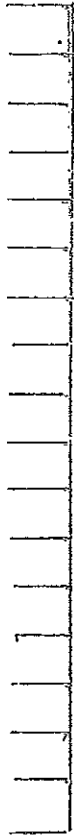
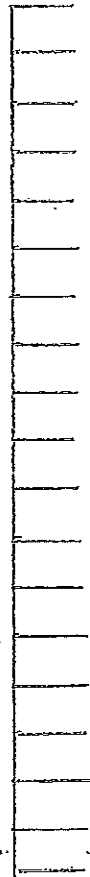

SHORT STREET

Proposed Site Plan

Dixboro Farmers Market

Dixboro Village Green, Inc.

Dixboro Village Green
Parcel ID #J -10-18-260-001

BEG AT NE COR OF LOT 22,
NORTHWEST SECTION, TH E 16
RDS TO NW COR OF LOT 8,
NORTHEAST SECTION, TH S 16
RDS TO SW COR OF LOT 1 OF
NORTHEAST SECTION, TH W 16
RDS TO PL OF BEG
VILLAGE OF DIXBORO.



CHURCH ROAD

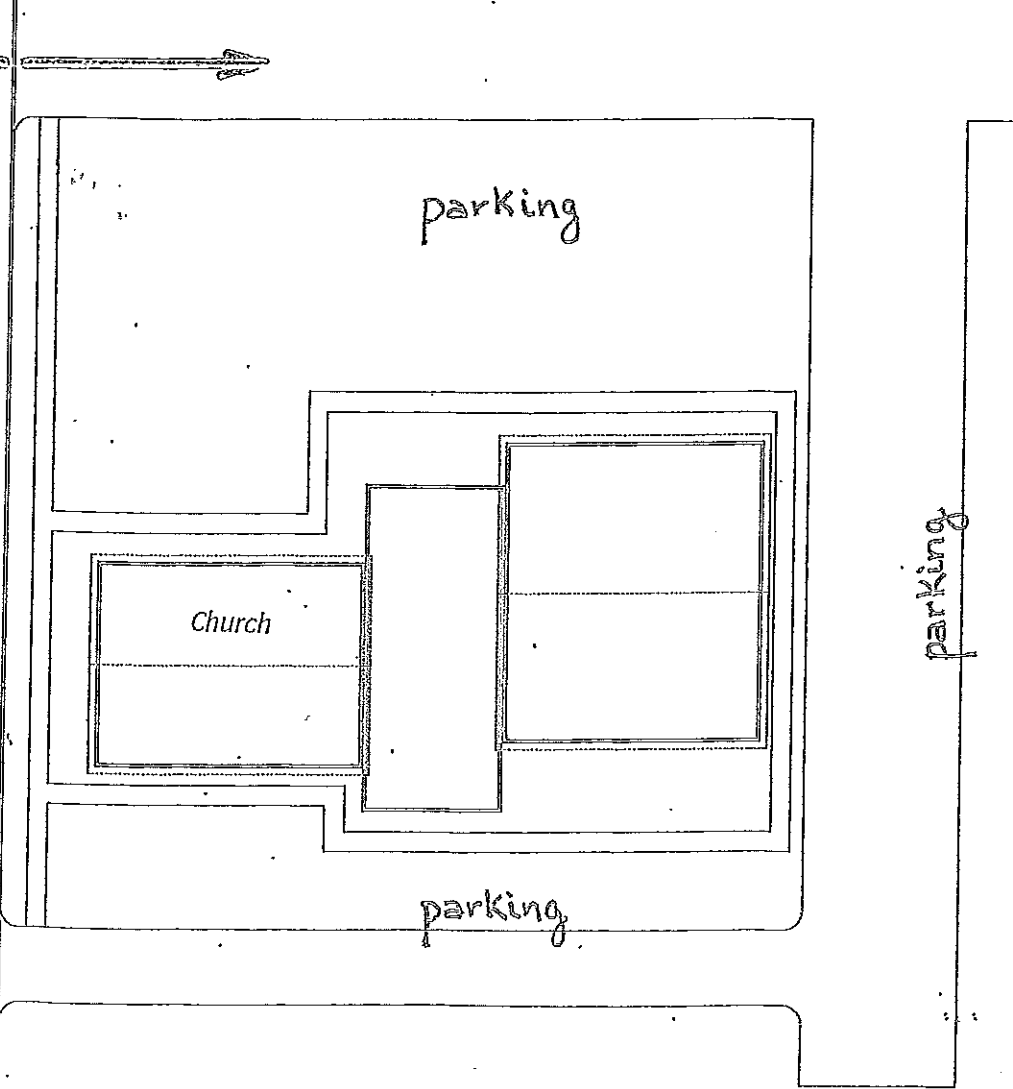
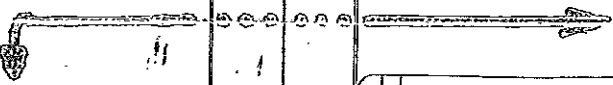

parking

Church

parking

parking



WASHTENAW COUNTY- Special Assessment Invoice
Office of the Water Resources Commissioner

INVOICE NO.
16-090

705 N. ZEEB ROAD, P.O. BOX 8645
 ANN ARBOR, MICHIGAN 48107-8645

TO: Superior Township
 ATTN: CLERK
 3040 N. Prospect Road
 Ypsilanti, MI 48198

PRE PAYMENT	INVOICE DATE 4/8/2016
PLEASE DIRECT INQUIRIES TO:	
Mallory Walczesky Assessment Coordinator	
TELEPHONE	734-222-3835

RE: PRE-PAYMENT

<u>W.C. DRAIN #</u>	<u>OBJECT #</u>	<u>DESCRIPTION</u>	<u>DUE FROM SUPERIOR TOWNSHIP</u>
9707	.44950	GEDDES RIDGE - PRE PAYMENT	40,000.00
GRAND TOTAL DUE			
FROM WASHTENAW COUNTY FINANCE:			\$ 40,000.00

PLEASE REMIT PAYMENT ALONG WITH A COPY OF THIS INVOICE TO:

WASHTENAW COUNTY TREASURER
 P.O. BOX 8645
 ANN ARBOR, MI 48107-8645

PLEASE RETURN COPY OF INVOICE WITH PAYMENT.

THANK YOU!

Ann Arbor SPARK
 201 South Division Street
 Suite 430
 Ann Arbor, MI 48104

Invoice

Date	Invoice #
9/30/2015	6966

Bill to
Superior Township Brenda McKinney 3040 North Prospect Street Ypsilanti, MI 48198

P.O. No.	Terms	Due Date
		9/30/2015

Quantity	Description	Rate	Amount
	2015 Dues	1,000.00	1,000.00
Total			\$1,000.00

Phone #	Fax #
734-761-9317	734-761-9062

memorandum

Date: April 15, 2016

To: Keith Lockie, Utilities Director

cc: David Phillips, Clerk

From: Jacob Rushlow, PE, Project Manager

Re: Sanitary Sewer Video Inspection Project
United Resource Contract Closeout and SAW Grant Update

At this time final payment to United Resource has been recommended, conditional upon receipt of the required consent of surety document. The United Resource contract for sanitary sewer video inspection work came in at \$23,620.66 under the contract amount. This final payment closes the field data collection portion of the SAW grant project.

OHM is currently proceeding with condition assessment based on the sanitary sewer and manhole inspection results. Initial analysis of the inspection results indicate that these areas of Township's system is in relatively good condition. Any areas identified as needing repairs will be compiled into a capital improvement plan and OHM can assist with obtaining bids for construction services to rehabilitate those manholes and sewer pipes. Next steps in the overall SAW grant project are assessing overall system conditions and determining critical assets, developing a revenue structure to sustain the sewer system in the most cost-efficient manner, and preparing the final asset management plan. We will also be assisting the Utilities Department with purchasing hardware and software for use in managing the sanitary sewer system as well as training for use of GIS system and GPS equipment.



Library Sidewalk

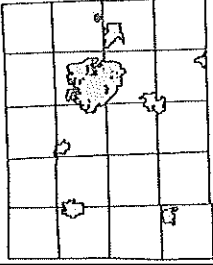

Legend

- Right of Way
- Quarter Sections
- Plat Boundary
- Parcels

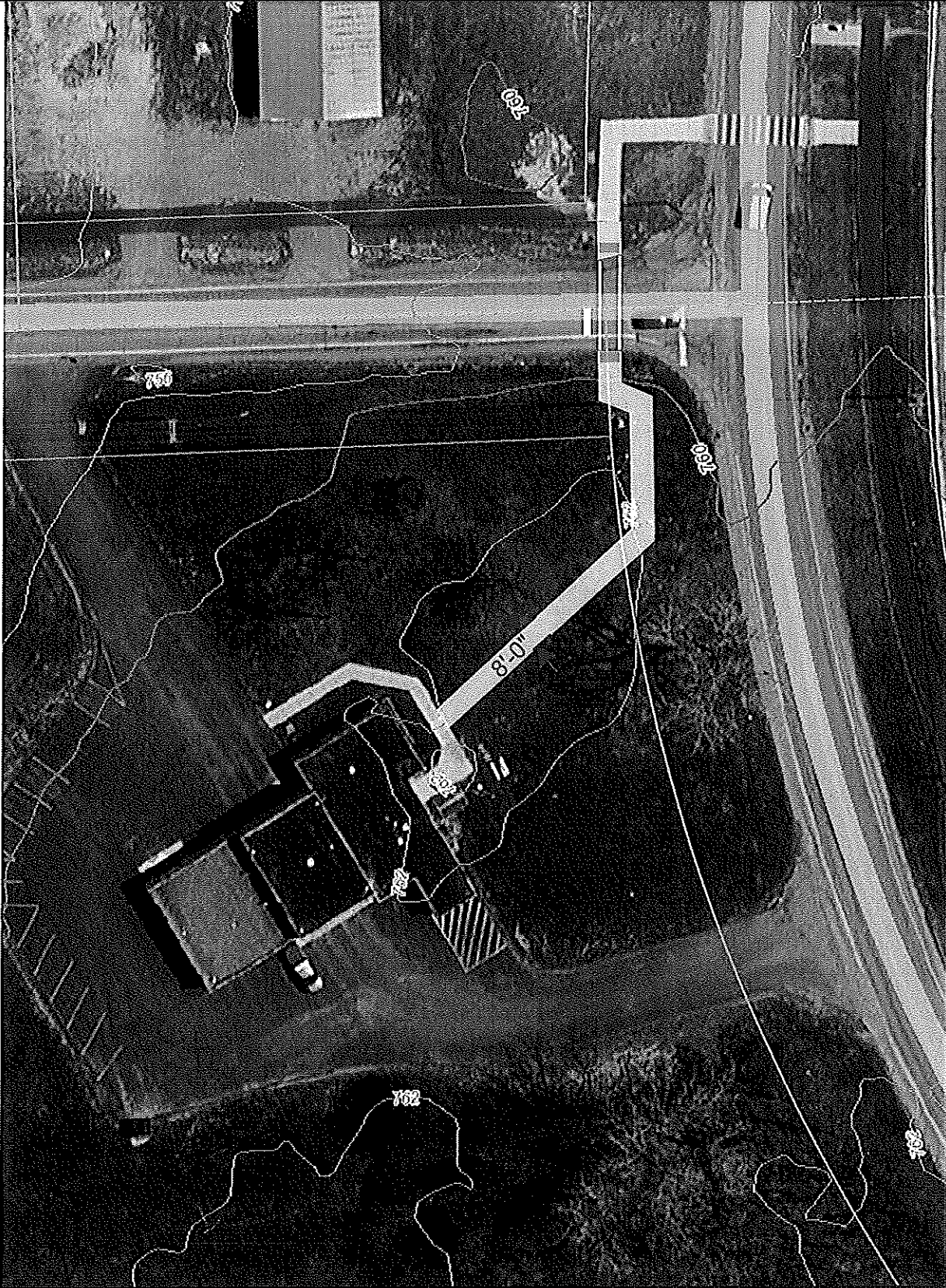

1: 599

© 2013 Washtenaw County

THIS MAP REPRESENTS PARCELS AT THE TIME OF PRINTING. THE OFFICIAL PARCEL TAX MAPS ARE MAINTAINED SOLELY BY THE WASHTENAW COUNTY EVALUATION DEPARTMENT AND CAN BE OBTAINED BY CONTACTING THAT OFFICE AT 734-622-8682.

The information contained in this cadastral map is used to locate, identify and inventory parcels of land in Washtenaw County for appraisal and taxing purposes only and is not to be construed as a warranty of accuracy. The information is provided with the understanding that the conclusions drawn from such information are solely the responsibility of the user. Any assumption of legal status of this data is hereby disclaimed.

NOTE: Parcels may not be to scale.
4/5/2016

Notes

Superior Township

This map is a user generated static output from an Internet mapping site and is for reference only. Data layers that appear on this map may or may not be accurate, current, or otherwise reliable.

THIS MAP IS NOT TO BE USED FOR NAVIGATION



ARCHITECTS. ENGINEERS. PLANNERS.

April 15, 2016

Mr. Ken Schwartz
Township Supervisor
Superior Township
3040 North Prospect Road
Ypsilanti, MI 48198

Regarding: Sanitary Sewer Video Inspection
OHM Job No. 0140-14-0050

Dear Mr. Schwartz:

Enclosed is Construction Estimate No. 2 (FINAL) and two (2) copies Change Order No. 2 for the referenced project. We would recommend approval of this Change Order. If you concur, please sign both sets, retain one copy for your files and return the remaining copy to OHM. Also enclosed are the required documents for final payment. These documents are as follows: 1) Contractor's Declaration; 2) Contractor's Affidavit; 3) Sworn Statement 4) Subcontractor Waiver of Lien and 5) Release of WCRC Permit #2015-612.

United Resource has completed the work shown on the attached construction estimate for the period ending April 14, 2016 and, *pending the receipt of the Consent of Surety*, we would recommend payment to the Contractor in the amount of \$29,432.94 which includes the full release of previously held retainage.

Sincerely,
OHM Advisors

A handwritten signature in black ink, appearing to read "Jacob Rushlow", is written over a horizontal line.

Jacob Rushlow, P.E.
Project Manager

cc: Keith Lockie, Utilities Department, Superior Township
Dave Phillips, Clerk, Superior Township
Jacob Rushlow, OHM
File

P:\0126_0165\0140140050_Superior_Twp_AMP\Construction\Estimates_CO\Estimates\No.2 (FINAL)\Superior_SanSewerVideoInsp_Est No.2 (FINAL)_CO No.2.doc

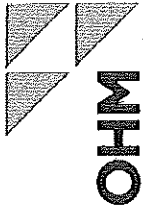

CONSTRUCTION ESTIMATE

ORCHARD, HILTZ & McCLIMENT, INC.
34900 Plymouth Road
Livonia, MI 48150

p: (734) 522-5711
f: (734) 522-6427
w: ohm-advisors.com

PROJECT: Charter Township of Superior - Sanitary Sewer Video Inspection

Job Numbers: 0140-14-0050

Estimate Number: 2 FINAL

Period End Date: 04/14/2016 15:27:25

CONTRACTOR: United Resource

Estimate Status: Approved

32940 Capitol Street

Contract Start Date: 11/20/2015

734-338-7730

Contract End Date: 12/20/2015

Livonia, MI 48150

Contract Duration: 30 days

STATUS: On Schedule

Print Date: 04/15/2016 12:45:43

Retainage: Lump Sum

Original Contract Amount

\$198,362.77

A) Changes due to CO No. 1:

(\$22,367.52)

Earnings this Period: \$13,287.48

Change Orders:

(\$23,620.66)

B) Changes due to CO No. 2:

(\$1,253.14)

Earnings to Date: \$174,742.11

Current Contract Amount

\$174,742.11

\$(23,620.66)

Previous Retainage: \$16,145.46

Retainage this Estimate: (\$16,145.46)

Less Total Retained to Date (Lump Sum): \$0.00

Net Earned: \$174,742.11

Previous Estimates: \$145,309.17

Amount Due Contractor: \$29,432.94

Amount Due Contractor includes \$16,145.46 of retainage previously held.

Recommended By:

Keith Lockie, P. E., Project Manager, Orchard, Hiltz & McCliment, Inc.

Date:

4/15/16

Approved By:

Date:

Keith Lockie, Utilities Director, Charter Township of Superior

Item No.	Description	Original Bid Quantity	Authorized Quantity	Unit Price	Period Quantity	Period Amount	Quantity to Date	Total Amount to Date
Division A: Division A								
1	Sanitary Sewer Video Inspection, 8 inch	41,575.00 Ft	45,738.30 (B)	\$0.95	-	-	45,738.30	\$43,451.39
2	Sanitary Sewer Video Inspection, 10 inch	17,271.00 Ft	19,084.90 (B)	\$0.97	-	-	19,084.90	\$18,512.35
3	Sanitary Sewer Video Inspection, 12 inch	18,716.00 Ft	16,140.60 (B)	\$1.00	-	-	16,140.60	\$16,140.60
4	Sanitary Sewer Video Inspection, 15 inch	11,157.00 Ft	12,713.40 (B)	\$1.15	-	-	12,713.40	\$14,620.41
5	Sanitary Sewer Video Inspection, 18 inch	2,875.00 Ft	2,726.00 (B)	\$1.15	-	-	2,726.00	\$3,134.90
6	Sanitary Sewer Video Inspection, Multi-Sensor, 21 inch	1,760.00 Ft	1,084.00 (B)	\$7.00	-	-	1,084.00	\$7,588.00
7	Sanitary Sewer Video Inspection, Multi-Sensor, 24 inch	321.00 Ft	316.00 (B)	\$7.00	-	-	316.00	\$2,212.00
8	Sanitary Sewer Video Inspection, Multi-Sensor, 30 inch	4,486.00 Ft	225.14 (AB)	\$7.00	118.14	\$826.98	225.14	\$1,575.98
9	Sanitary Sewer Video Inspection, Multi-Sensor, 36 inch	5,376.00 Ft	5,183.00 (B)	\$7.00	-	-	5,183.00	\$36,281.00
10	Sanitary Sewer Cleaning, 8 inch	10,394.00 Ft	8,309.50 (B)	\$0.30	-	-	8,309.50	\$2,492.85
11	Sanitary Sewer Cleaning, 10 inch	4,318.00 Ft	3,200.50 (B)	\$0.35	-	-	3,200.50	\$1,120.18
12	Sanitary Sewer Cleaning, 12 inch	4,679.00 Ft	1,923.90 (B)	\$0.35	-	-	1,923.90	\$673.37
13	Sanitary Sewer Cleaning, 15 inch	2,790.00 Ft	1,481.70 (B)	\$0.35	-	-	1,481.70	\$518.60
14	Sanitary Sewer Cleaning, 18 inch	719.00 Ft	0.00 (B)	\$0.40	-	-	-	-
15	Sanitary Sewer Cleaning, 21 inch	440.00 Ft	0.00 (B)	\$1.05	-	-	-	-
16	Sanitary Sewer Cleaning, 24 inch	81.00 Ft	0.00 (B)	\$1.40	-	-	-	-
17	Sanitary Sewer Cleaning, 30 inch	1,122.00 Ft	0.00 (B)	\$2.10	-	-	-	-
18	Sanitary Sewer Cleaning, 36 inch	1,344.00 Ft	0.00 (B)	\$2.75	-	-	-	-
19	Protruding Leads	100.00 Ea	0.00 (B)	\$45.00	-	-	-	-
20	By-Pass Pumping	1.00 Ls	0.00 (B)	\$1.00	-	-	-	-
21	Traffic Control	1.00 Ls	1.00	\$5,000.00	-	-	1.00	\$5,000.00
Additional Items to the Contract								
22	Heavy Cleaning of the 30" pipe on Harvest Lane	0.00 Hour	38.50 (B)	\$300.00	38.50	\$11,550.00	38.50	\$11,550.00
23	Disposal of Debris	0.00 Cyd	12.14 (B)	\$75.00	12.14	\$910.50	12.14	\$910.50
24	Sanitary Sewer Video Inspection, 30 Inch	0.00 Ft	2,560.00 (AB)	\$3.50	-	-	2,560.00	\$8,960.00
					Division A Sub-Total:	\$13,287.48		
					Retainage:	(\$16,145.46)		
								\$174,742.11



CHANGE ORDER

ORCHARD, HILTZ & McCLIMENT, INC.
34000 Plymouth Road
Livonia, MI 48150

p: (734) 522-8711
f: (734) 522-8427
w: ohm-advisors.com

Change Order Number: 2
Date: 12/15/2015
Print Date: 04/14/2016 15:30:41
Job Numbers: 0140-14-0050

PROJECT: Charter Township of Superior - Sanitary Sewer Video Inspection

OWNER: Charter Township of Superior
3040 North Prospect Road
Ypsilanti, MI 48198

CONTRACTOR: United Resource
32940 Capitol Street
Livonia, MI 48150
734-338-7730

TO THE CONTRACTOR:

You are hereby directed to comply with the changes to the contract documents.
This change order reflects work completed or anticipated.

ORCHARD, HILTZ & McCLIMENT, INC.
34000 Plymouth Road
Livonia, Michigan 48150 Phone (734) 522-8711

CURRENT PROJECT PLANS AND SPECIFICATIONS WILL BE ADHERED TO UNLESS SPECIFICALLY CHANGED BY THIS CHANGE ORDER DOCUMENT.

The changes addressed by this Change Order hereby increase the contract duration by 0 days.

Table with 2 columns: Description and Amount. Rows include: THE CONTRACT AMOUNT SHALL BE CHANGED BY THE SUM OF: \$(1,253.14); Original Contract Amount: \$198,362.77; Contract Amount Including Previous Change Orders: \$175,995.25; Amount of this Change Order: \$(1,253.14); REVISED CONTRACT AMOUNT: \$174,742.11

Accepted By: [Signature]
United Resource

Date: 4/15/16

Recommended By: [Signature]
Jacob Rushlow, P.E., Project Manager, Orchard, Hiltz & McCliment, Inc.

Date: 4/15/16

Approved By:
Keith Lockle, Utilities Director, Charter Township of Superior

Date:

Item No.	Description	Previous Authorized Quantity	Quantity Change	New Authorized Quantity	Unit Price	Total Increase
----------	-------------	------------------------------	-----------------	-------------------------	------------	----------------

THE FOLLOWING ITEMS AND OR CONTRACT UNIT PRICES SHALL BE ADDED TO THE CONTRACT AMOUNT

Division A: Division A

1	Sanitary Sewer Video Inspection, 8 inch	41,575.00	Ft	4,163.30	45,738.30	\$0.95	\$3,955.14
2	Sanitary Sewer Video Inspection, 10 inch	17,271.00	Ft	1,813.90	19,084.90	\$0.97	\$1,759.48
4	Sanitary Sewer Video Inspection, 15 inch	11,157.00	Ft	1,556.40	12,713.40	\$1.15	\$1,789.86
8	Sanitary Sewer Video Inspection, Multi-Sensor, 30 inch	118.14	Ft	107.00	226.14	\$7.00	\$749.00
24	Sanitary Sewer Video Inspection, 30 inch	2,345.00	Ft	215.00	2,560.00	\$3.50	\$752.50

Additional Items to the Contract:

22	Heavy Cleaning of the 30" pipe on Harvest Lane		Hour	38.50	38.50	\$300.00	\$11,550.00
23	Disposal of Debris		Cyd	12.14	12.14	\$75.00	\$910.50

SUB-TOTAL INCREASES DIVISION A:

\$21,466.48

THE FOLLOWING ITEMS AND OR CONTRACT UNIT PRICES SHALL BE SUBTRACTED FROM THE CONTRACT AMOUNT

Division A: Division A

3	Sanitary Sewer Video Inspection, 12 inch	18,716.00	Ft	(2,575.40)	16,140.60	\$1.00	(\$2,575.40)
5	Sanitary Sewer Video Inspection, 18 inch	2,875.00	Ft	(149.00)	2,726.00	\$1.15	(\$171.35)
6	Sanitary Sewer Video Inspection, Multi-Sensor, 21 inch	1,760.00	Ft	(676.00)	1,084.00	\$7.00	(\$4,732.00)
7	Sanitary Sewer Video Inspection, Multi-Sensor, 24 inch	321.00	Ft	(5.00)	316.00	\$7.00	(\$35.00)
9	Sanitary Sewer Video Inspection, Multi-Sensor, 36 inch	5,376.00	Ft	(193.00)	5,183.00	\$7.00	(\$1,351.00)
10	Sanitary Sewer Cleaning, 8 inch	10,394.00	Ft	(2,084.50)	8,309.50	\$0.30	(\$625.35)
11	Sanitary Sewer Cleaning, 10 inch	4,318.00	Ft	(1,117.50)	3,200.50	\$0.35	(\$391.13)
12	Sanitary Sewer Cleaning, 12 inch	4,679.00	Ft	(2,755.10)	1,923.90	\$0.35	(\$954.29)
13	Sanitary Sewer Cleaning, 15 inch	2,790.00	Ft	(1,308.30)	1,481.70	\$0.35	(\$457.91)
14	Sanitary Sewer Cleaning, 18 inch	718.00	Ft	(718.00)	0.00	\$0.40	(\$287.60)
15	Sanitary Sewer Cleaning, 21 inch	440.00	Ft	(440.00)	0.00	\$1.05	(\$462.00)
16	Sanitary Sewer Cleaning, 24 inch	81.00	Ft	(81.00)	0.00	\$1.40	(\$113.40)
17	Sanitary Sewer Cleaning, 30 inch	1,122.00	Ft	(1,122.00)	0.00	\$2.10	(\$2,356.20)
18	Sanitary Sewer Cleaning, 36 inch	1,344.00	Ft	(1,344.00)	0.00	\$2.75	(\$3,696.00)
19	Protruding Leads	100.00	Ea	(100.00)	0.00	\$45.00	(\$4,500.00)
20	By-Pass Pumping	1.00	Ls	(1.00)	0.00	\$1.00	(\$1.00)

SUB-TOTAL DECREASES DIVISION A:

(\$22,719.82)

CONTRACTOR'S DECLARATION

I HEREBY DECLARE THAT I HAVE NOT, during the period

December 10, 2015

to

April 15 A.D., 2016 performed any work, furnished any material, sustained any loss, damage or delay for any reason, including soil conditions encountered or created, or otherwise done anything for which I shall ask, demand, sue for or claim compensation from Charter Township of Superior or his agents, in addition to the regular items set forth in the Contract numbered 0140-14-0050 and dated October 14 A.D., 2015 for the Agreement executed between myself and the OWNER, and in the Change Orders for work issued by the OWNER in writing as provided thereunder, except as I hereby make claim for additional compensation and/or extension of time, as set forth on the itemized statement attached hereto.

There (is) (is not) an itemized statement attached.

Date: 4-15-2016

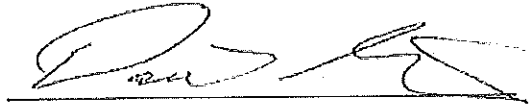

By: David Guth

Title: President

Sanitary Sewer Video Inspection
Charter Township of Superior
OHM 0140-14-0050

Final Pay Estimate 4/15/2016

EARNINGS THIS PERIOD	\$13,287.48
EARNINGS TO DATE	\$174,742.11
LESS PREVIOUSLY PAID	<u>-\$145,309.17</u>
TOTAL DUE FINAL PAY ESTIMATE	\$29,432.94

CONTRACTOR'S AFFIDAVIT

STATE OF MICHIGAN)
)SS.
COUNTY OF Wayne)

The undersigned, David Guth - President of United Resource, CONTRACTOR, hereby represents that on October 14, 2015 he (it) was awarded a Contract by Charter Township of Superior hereinafter called the OWNER, to construct Sanitary Sewer Video Inspection in accordance with the terms and conditions of Contract No. OHM 0140-14-0050 ; and the undersigned further represents that the subject work has now been accomplished and the said Contract has now been completed.

The undersigned hereby warrants and certifies that all of his (its) indebtedness arising by reason of said Contract has been fully or satisfactorily secured, and that all claims from subcontractors and others for labor and material used in accomplishing the said project, as well as all other claims arising from performance of said Contract, have been fully paid or satisfactorily secured. The undersigned further agrees that if any such claim should hereafter arise, he (it) shall assume responsibility for same immediately upon request to do so by the OWNER.

The undersigned, for a valuable consideration, receipt of which is hereby acknowledged, does further hereby waive, release and relinquish any and all claims or right of lien which the undersigned now has or may hereafter acquire upon the subject premises for labor and material used in accomplishing said project owned by the OWNER.

This affidavit is freely and voluntarily given with full knowledge of the facts on this 15th day of April, 2016 .

United Resource, LLC

Contractor

By: 

Title President

Subscribed and sworn to before me, a Notary Public in and for Wayne County, Michigan, on this 15th day of April, 2016 .

SAMANTHA HARRIS
Notary Public, State of Michigan
County of Wayne
My Commission Expires 08-26-2021
Acting in the County of Wayne

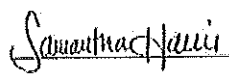
Notary Public: 

My Commission expires: 08-26-2021

SWORN STATEMENT

State of Michigan

County of: Wayne

Date: April 15, 2016

David Guth (deponent) being duly sworn deposes and says:

1. That United Resource LLC is the Contractor/Subcontractor for an improvement to the property described on the following page.
2. That the following is a statement of each subcontractor and supplier and laborer, for which the payment of wages or fringe benefits and withholdings is due but unpaid, with whom the Contractor/Subcontractor has Contracted/Subcontracted for performance under the Contract with the Owner or Lessee of the property, and that the amounts due to the persons as of the date hereof are correctly and fully set forth opposite their names as follows:

Name of Subcontractor, Supplier or Laborer	Type of Improvement Furnished	Total Contract Price	Amount Already Paid	Amount Currently Owing	Amount of Laborer Wages Due but Unpaid	Amount of Labor, Fringe Benefits & Withholdings due but Unpaid
Red Zone	Multi Sensor Video Inspection of 21", 24", 30" & 36"	\$43,445.35	\$43,445.35	\$0.00	\$0.00	\$0.00

The contracts or subcontracts cited herein are for improvement to the following described real property situated in Washtenaw County, Michigan, described as:

(Insert legal description of property) _____
Superior Township Sanitary Sewer Video Inspection Project

Commonly known as:

OHM Job Number: 0140-14-0050

3. That the Contractor has not procured material from, or subcontracted with, any person other than those set forth above and owes no money for the improvement other than the sums set forth above.
4. Deponent further says that he makes the foregoing statement as the Contractor/Subcontractor or as Controller of the Contractor/Subcontractor for the purpose of representing to the owner of the above described premises and his agents that the above described property is free from claims of construction liens, or the possibility of construction liens, except as specifically set forth above and except for claims of construction liens by laborers which may be provided pursuant to Section 109 of the Construction Lien Act, Act No. 497 of the Public Acts of 1980, as amended, being Section 570.1109 of the Michigan Compiled Laws.

WARNING TO OWNER: An Owner of the above described property may not rely on this sworn statement to avoid the claim of a Subcontractor, Supplier or Laborer who has provided a Notice of Furnishing (or a Laborer who may provide a Notice of Furnishing pursuant to Section 109 of the Construction Lien Act) to the Designee or to the Owner if the Designee is not named or has died.

Dated: 4-15-16

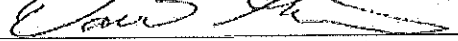

Signature of Deponent

WARNING TO DEPONENT: A person, who with intent to defraud, gives a false sworn statement is subject to criminal penalties as provided in Section 110 of the Construction Lien Act, Act No. 497 of the Public Acts of 1980, as amended, being Section 570.1110 of the Michigan Compiled Laws.

Subscribed and sworn to before me on: April 15, 2016 in Wayne County, Michigan

My commission expires: 08-20-2021 Signature: Samantha Harris

SAMANTHA HARRIS
Notary Public, State of Michigan
County of Wayne
My Commission Expires 08-20-2021
Acting in the County of Wayne

SWORN STATEMENT

State of PA

County of Allegheny } S

being duly sworn, states the following:

RedZone Robotics Inc.

Is the (contractor)(subcontractor) for an improvement to the following real property in Superior County, Washtenaw

described as follows: Sanitary Sewer Closed Circuit Video Inspections

The following is a statement of each subcontractor, supplier and laborer, for whom payment of wages or fringe benefits and withholdings is due but unpaid, with whom the (contractor)(subcontractor) has (contracted)(subcontracted) for performance under the contract with the owner or lessee, and the amounts due to the persons as of the date of this statement are correctly and fully set forth opposite their names:

Name Address and Phone Number of Subcontractor, Supplier or Laborer	Type of Improvement Furnished	Total Contract Price	Amount Already Paid	Amount Currently Owning	Balance to complete (optional)	Amount of Laborer Wages Due but unpaid	Amount of Laborer Fringe Benefits and Withholdings Due But Unpaid
Totals		\$0.00	\$0.00	\$0.00	\$0.00	\$0.00	\$0.00

(Some columns may not be applicable to all persons listed)

The contractor has not procured material from, or subcontracted with, any person other than those set forth and owes no money for the improvement other than the sums set forth.*

I make this statement as the (contractor)(subcontractor) or as _____ of the (contractor)(sub-contractor) to represent to the owner or lessor of the property and his or her agents that the property is free from claims of construction liens, or the possibility of construction liens, except as specifically set forth in this statement and except for claims of construction liens by laborers that may be provided under Section 109 of the Construction Lien Act, 1980 PA 497, MCL 570.1109.

WARNING TO OWNER OR LESSEE: AN OWNER OR LESSEE OF THE PROPERTY MAY NOT RELY ON THIS SWORN STATEMENT TO AVOID THE CLAIM OF A SUBCONTRACTOR, SUPPLIER OR LABORER WHO HAS PROVIDED A NOTICE OF FURNISHING OR A LABORER WHO MAY PROVIDE A NOTICE OF FURNISHING UNDER SECTION 109 OF THE CONSTRUCTION LIEN ACT, 1980 PA 497, MCL 570.1109 TO THE DESIGNEE OR TO THE OWNER OR LESSEE IF THE DESIGNEE IS NOT NAMED OR HAS DIED.

ON RECEIPT OF THIS SWORN STATEMENT, THE OWNER OR LESSEE, OR THE OWNER'S OR LESSEE'S DESIGNEE MUST GIVE NOTICE OF ITS RECEIPT, EITHER IN WRITING, OR BY TELEPHONE, OR PERSONALLY, TO EACH SUBCONTRACTOR, SUPPLIER, AND LABORER WHO HAS PROVIDED A NOTICE OF FURNISHING UNDER SECTION 109 OR, IF A NOTICE OF FURNISHING IS EXCUSED UNDER SECTION 108 OR 108A, TO EACH SUBCONTRACTOR, SUPPLIER, AND LABORER NAMED IN THE SWORN STATEMENT. IF A SUBCONTRACTOR, SUPPLIER WHO HAS PROVIDED A NOTICE OF FURNISHING OR WHO IS NAMED IN THE SWORN STATEMENT MAKES A REQUEST, THE OWNER, LESSEE, OR DESIGNEE SHALL PROVIDE THE REQUESTER A COPY OF THE SWORN STATEMENT WITHIN 10 BUSINESS DAYS AFTER RECEIVING THE REQUEST.

RedZone Robotics Inc., Dan Yingst, Chief Operating Officer

Dependent Printed Name

[Handwritten Signature]

Dependent Signature

April 14th, 2016

Date

WARNING TO DEPENDENT: A PERSON WHO GIVES A FALSE SWORN STATEMENT WITH INTENT TO FRAUD IS SUBJECT TO CRIMINAL PENALTIES AS PROVIDED IN SECTION 110 OF THE CONSTRUCTION LIEN ACT, 1980 PA 497, MCL 570.1110.

Subscribed and sworn to before me this

14 day of April, 2016

COMMONWEALTH OF PENNSYLVANIA
NOTARIAL SEAL
Rose Mary Mitsch, Notary Public
Shaler Twp., Allegheny County
My Commission Expires Nov. 21, 2017
PENNSYLVANIA ASSOCIATION OF NOTARIES

Notary Public, PA

County, Allegheny

My Commission Expires:

Nov 21, 2017

*Materials furnished by a contractor or a subcontractor out of his or her own inventory, and which has not been purchased specifically for the purpose of performing the contract, need not be listed.

United Resource, LLC
32940 Capitol Street
Livonia, MI 48150

Subcontractor Advice Notice
Certificate Waiver and Release of Lien

To: RedZone Robotics
91 43rd Street
Pittsburgh, PA 15201

Project: Charter Township of Superior
Sanitary Sewer Video Inspection

Amount Earned to Date \$43,445.35

Final Payment \$43,445.35

In consideration for the final payment of the above items and other good and valuable consideration, the undersigned subcontractor hereby waives and relinquishes all mechanic's liens, claims of liens, stop notice, and labor and material bond rights and warrants that all labor, material or equipment furnished by subcontractor has been fully paid for by subcontractor and that there are no amounts unpaid in favor of its subcontractors or material suppliers or any other persons furnishing labor or material to subcontractor and utilized in the performance of the contract of the above described project. Additionally the undersigned subcontractor hereby releases and holds harmless the Charter Township of Superior and United Resource, LLC from any and all claims arising out of or in connection with the above project and subcontract. Delay in returning this certificate will result in delay of subsequent payment, as this information is required.

Subscribed and sworn before me this

14 day of April 2017

[Signature]

Notary Public, PA County, Allegheny

My Commission Expires: Nov 21, 2017

Subcontractor
Redzone Robotics

By: [Signature]

Dan Yingst, Chief Operating Officer

Date April 14th, 2016

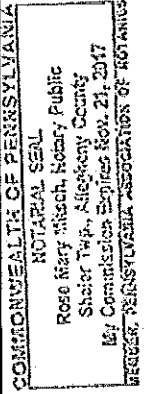

COMMISSIONERS
DOUGLAS E. FULLER
CHAIR
BARBARA RYAN FULLER
VICE-CHAIR
WILLIAM MCFARLANE
MEMBER



ROY D. TOWNSEND, P.E.
MANAGING DIRECTOR
SHERYL SODERHOLM SIDDALL, P.E.
COUNTY HIGHWAY ENGINEER
JAMES D. HARMON, P.E.
DIRECTOR OF OPERATIONS
TELEPHONE (734) 761-1500
FAX (734) 761-3737

WASHTENAW COUNTY
BOARD OF COUNTY ROAD COMMISSIONERS
856 NORTH ZEEB ROAD
ANN ARBOR, MICHIGAN 48103
WWW.WCROADS.ORG

April 14, 2016

Superior Township Building Department
3040 N. Prospect Rd
Ypsilanti, MI 48198

RE: Surveying - Clark Rd Superior Twp
WCRC Permit# 2015-612

Dear Sir/Madam;

The Washtenaw County Road Commission Permit staff performed a final inspection of the above noted project, per the conditions of the right-of-way permit. This inspection determined that all permit requirements have been satisfactorily completed; therefore, your permit has been finalized.

Thank you for your cooperation. Should you have any questions or concerns, please contact our office at 734-761-1500.

Kind Regards,

A handwritten signature in black ink that reads "Lauren Purdy".

Lauren Purdy
Permits Clerk

XC: United Resources
Superior Township (via email)
File



SUPERIOR TOWNSHIP BILLS FOR PAYMENT

Date: April 18, 2016

GENERAL FUND	NONE TO SUBMIT
FIRE	NONE TO SUBMIT
LAW	NONE TO SUBMIT
PARK	NONE TO SUBMIT
BUILDING	NONE TO SUBMIT
UTILITY	\$7,532.37

Superior Township Utility Department
 Invoice Approval Report
 As of April 18, 2016

10:16 AM
 04/14/16

Type	Date	Num	Memo	Due Date	Open Balance
Duke's Root Control, Inc. Bill	03/30/16	11787	Root Control Service	04/19/16	7,532.37
Total Duke's Root Control, Inc.					7,532.37
TOTAL					7,532.37



SUPERIOR TOWNSHIP Record of Disbursements

Date: April 18, 2016

*Contains all checks written since last report for the following funds:

General Bank - includes all checks written from the following funds:

- 101 - General Fund
- 204 - Legal Defense Fund
- 219 - Streetlight Fund
- 220 - Side Street Maintenance Fund
- 249 - Building Fund
- 266 - Law Fund
- 508 - Park Fund
- 701 - Trust & Agency Fund

- 206 - Fire Fund
- 592 - Utility Dept.

Note: Some of these checks were presented to the board for approval. All others are either pre-approved or under \$3,000.00 for Government Funds and \$5,000 for Utility Dept.

Check Date	Bank	Check	Vendor Name	Description	Amount
03/22/2016	GENL	37851	AL'S CLEANING SERVICE	MISC CLEANING @ TOWN HALL	84.00
03/22/2016	GENL	37852	ALL SEASONS LANDSCAPING CO. INC.	BLOWER REPAIR	501.44
03/22/2016	GENL	37853	ANN ARBOR AREA TRANSPORTATION AUTH.	MARCH 2016	5,769.51
03/22/2016	GENL	37854	BLUE CROSS/BLUE SHIELD-M	MEDICAL INSURANCE - APRIL 16	6,923.56
03/22/2016	GENL	37855	CINTAS CORPORATION - 300	RUG SERVICE WEEK OF 3/17/16	57.64
03/22/2016	GENL	37856	CONGDON'S ACE HARDWARE	LITTLE LIBRARY SUPPLIES	38.75
03/22/2016	GENL	37857	CONSUMERS LIFE INSURANCE CO	LIFE INSURANCE - APRIL 2016	161.17
03/22/2016	GENL	37858	DANIEL ALLEN	REIMBURSE FOR EASTER EGG HUNT SUPPLIES	183.52
03/22/2016	GENL	37859	DELTA DENTAL	DENTAL INSURANCE - APRIL 16	857.12
03/22/2016	GENL	37860	EDWIN MANIER	ELECTRICAL INSPECTIONS FOR THE MONTH OF	600.00
03/22/2016	GENL	37861	GENE BUTMAN FORD SALES, INC.	FORD VAN REPAIRS	368.57
03/22/2016	GENL	37862	MARKS	PIGOTT - MIOSHA & RISK MANAGEMENT TRAINI	25.00
03/22/2016	GENL	37863	NEW CHRISTIAN LOVE FELLOWSHIP	PRECINCT RENTAL	500.00
03/22/2016	GENL	37864	RON PEATRY	MILEAGE REIMBURSEMENT 3/14/16-3/18/16	85.86
03/22/2016	GENL	37865	SPEARS FIRE & SAFETY	FIRE EXT. MAINTENANCE	55.00
03/22/2016	GENL	37866	SUPERIOR TWP PAYROLL FUND	CASH TRANSFER 3/24/16 PAYROLL	52,016.50
03/22/2016	GENL	37867	VISION SERVICE PLAN	VISION INSURANCE - APRIL 2016	166.76
03/22/2016	GENL	37868	WASHTENAW COUNTY TREASURER	OVERTIME - FEBRUARY 2016	2,715.43
03/22/2016	GENL	37869	WEX BANK	FUEL - MAR 2016	51.77
03/29/2016	GENL	37870	AL'S CLEANING SERVICE	MISC CLEANING @ TOWN HALL	28.00
03/29/2016	GENL	37871	BRENDA MCKINNEY	MILEAGE 02/10/16 THRU 3/21/16	85.86
03/29/2016	GENL	37872	CINTAS CORPORATION - 300	RUG SERVICE WEEK OF 3/24/16	57.64
03/29/2016	GENL	37873	DTE ENERGY	STREETLIGHTS - FEB 2016	6,706.55
03/29/2016	GENL	37874	GBS INC.	ABSENTEE VOTER RETURN ENVELOPES	1,122.38
03/29/2016	GENL	37875	MAILFINANCE	POSTAGE METER LEASE - JAN-APRIL 16	621.09
03/29/2016	GENL	37876	PATRICK PIGOTT	CELL PHONE STIPEND - MAR 16	31.97
03/29/2016	GENL	37877	STANDARD PRINTING	#10 REGULAR ENVELOPES	95.00
03/29/2016	GENL	37878	SUPERIOR TOWNSHIP CREDIT CARD ACCT	CR CARD - BOARD OF REVIEW FOOD	149.97
03/29/2016	GENL	37879	SUPERIOR TWP FIRE FUND	MONEY DUE TO FIRE FROM ST JOE'S PAYMENT	50.00
03/29/2016	GENL	37880	SUPERIOR TWP PAYROLL FUND	PENSION /HCSP - MARCH 2016	7,640.46
03/29/2016	GENL	37881	SUPERIOR TWP UTILITY DEPARTMENT	TELEPHONES - MARCH 2016	43.91
03/29/2016	GENL	37882	WEX BANK	FUEL - MARCH 2016	91.60
04/05/2016	GENL	37883	AL'S CLEANING SERVICE	MISC CLEANING @ TOWN HALL	28.00
04/05/2016	GENL	37884	CINTAS CORPORATION - 300	RUG SERVICE WEEK OF 3/31/16	57.64
04/05/2016	GENL	37885	CLYDE NEWTON	STUMP GRINDING - GALE ROAD	1,000.00
04/05/2016	GENL	37886	DAVID BORNEMAN L.L.C.	PRESCRIBED BURN AT CHERRY HILL NATURE PR	3,700.00
04/05/2016	GENL	37887	DIXBORO UNITED METHODIST CHURCH	PRECINCT RENTAL 3/8/16 ELECTION	250.00
04/05/2016	GENL	37888	DTE ENERGY	GEN/LAW SPLIT/OLD TOWN HALL ELEC - MAR 1	1,343.53
04/05/2016	GENL	37889	EDWIN MANIER	ELECTRICAL INSPECTIONS FOR THE MONTH OF	630.00
04/05/2016	GENL	37890	HOME DEPOT CREDIT SERVICES	SHOP SUPPLIES	38.45
04/05/2016	GENL	37891	LOWE'S	WHEELBARROW WHEEL	19.74
04/05/2016	GENL	37892	LUCAS LAW, PC	CONDEMNATION APPRAISALS - BROMLEY/REDWOOD	2,500.00
04/05/2016	GENL	37893	MICHELLE MCINTYRE	RECEIVING BOARD 3/8/16 ELECTION	75.00
04/05/2016	GENL	37894	MICHIGAN ELECTION RESOURCES	EPB BINDER PRECINCT SUPPLY KIT	289.82
04/05/2016	GENL	37895	PLANNING & ZONING CENTER, INC.	2016 YEARLY SUBSCRIPTION	165.00
04/05/2016	GENL	37896	RON PEATRY	MILEAGE REIMBURSEMENT 3/21/16 - 4/1/16	137.16
04/05/2016	GENL	37897	SAM'S CLUB/SYNCHRONY BANK	2016 MEMBERSHIP	100.00
04/05/2016	GENL	37898	SIGNS BY TOMORROW	50% DEPOSIT REQUIRED TO BEGIN PRODUCTION	4,630.00
04/05/2016	GENL	37899	STANDARD PRINTING	NEWSLETTER	4,209.04
04/05/2016	GENL	37900	STAPLES CREDIT PLAN	OFFICE SUPPLIES	38.96
04/05/2016	GENL	37901	SUPERIOR TWP PAYROLL FUND	HSA FEES - APRIL 2016	51,304.27
04/05/2016	GENL	37902	SUPERIOR TWP UTILITY DEPARTMENT	CELLPHONES - MARCH 2016	91.29
04/05/2016	GENL	37903	TERMINIX PROCESSING CENTER	PEST CONTROL - MARCH 2016	81.00
04/05/2016	GENL	37904	VERIZON WIRELESS	HOT SPOT CHARGES - MARCH 2016	80.16
04/05/2016	GENL	37905	WASHTENAW COUNTY TREASURER	2016 CONTRACT - APRIL	130,590.83
04/05/2016	GENL	37906	WEX BANK	FUEL - MARCH 2016	130.88
04/12/2016	GENL	37907	WASHTENAW COUNTY TREASURER	DELINQUENT PERSONAL PROPERTY TAXES	2,818.70

Check Date	Bank	Check	Vendor Name	Description	Amount
04/12/2016	GENL	37908	ABSOPURE WATER COMPANY	COOLER RENTAL - MAR 2016	57.25
04/12/2016	GENL	37909	AL'S CLEANING SERVICE	MISC CLEANING @ TOWN HALL	26.00
04/12/2016	GENL	37910	ANN ARBOR PUBLIC SCHOOLS	DELINQUENT PERSONAL PROERTY TAXES	17.30
04/12/2016	GENL	37911	CANON SOLUTIONS AMERICA	COPIER MAINTENANCE FEB-MAR	185.65
04/12/2016	GENL	37912	CARL SADDLER	MILEAGE REIMBURSEMENT	8.10
04/12/2016	GENL	37913	CINTAS CORPORATION - 300	RUG SERVICE WEEK OF 4/7/16	57.64
04/12/2016	GENL	37914	COMCAST	INTERNET SERVICES - MAR 2016	93.90
04/12/2016	GENL	37915	CONGDON'S ACE HARDWARE	LIGHT BULBS AND CLEANING SUPPLIES	58.41
04/12/2016	GENL	37916	DONALD PENNINGTON	CONSULTING SERVICES - MARCH 2016	1,040.00
04/12/2016	GENL	37917	EDWARD WEIMER	DUMP TICKET REIMBURSEMENT	22.00
04/12/2016	GENL	37918	ELECTION SYSTEMS & SOFTWARE, INC.	MAINTENANCE FEE 7/1/2016 THRU 6/30/2017	618.40
04/12/2016	GENL	37919	GLEMP, INC.	ORDINANCE NOTICES	588.00
04/12/2016	GENL	37920	KATHY MARX	DUMP TICKET REIMBURSEMENT	44.00
04/12/2016	GENL	37921	MLIVE MEDIA GROUP	PUBLISHING - MAR 2016	276.99
04/12/2016	GENL	37922	SUGAR BUSH FARMS	SUPERIOR DAY PETCHING FARM	250.00
04/12/2016	GENL	37923	SUPERIOR TOWNSHIP CREDIT CARD ACCT	QUICKBOOKS TRAINING - JO JULIUS	1,836.32
04/12/2016	GENL	37924	SUPERIOR TWP FIRE FUND	DELINQUENT PERSONAL PROERTY TAXES	1,201.80
04/12/2016	GENL	37925	VICTOR L. LILLICH, J.D.	LEGAL SERVICES - APRIL 2015	690.00
04/12/2016	GENL	37926	WASHTENAW COMMUNITY COLLEGE	DELINQUENT PERSONAL PROERTY TAXES	779.05
04/12/2016	GENL	37927	WASHTENAW COUNTY TREASURER	TRAILER FEES - MARCH 2016	1,352.50
04/12/2016	GENL	37928	WASHTENAW INTERMEDIATE SCHOOL DIST	DELINQUENT PERSONAL PROERTY TAXES	833.25
04/12/2016	GENL	37929	YPSILANTI COMMUNITY SCHOOLS	DELINQUENT PERSONAL PROERTY TAXES	3,396.43
04/12/2016	GENL	37930	YPSILANTI DISTRICT LIBRARY	DELINQUENT PERSONAL PROERTY TAXES	697.76

GENL TOTALS:

Total of 80 Checks: 306,348.25
 Less 0 Void Checks: 0.00

Total of 80 Disbursements: 306,348.25

Check Date	Bank	Check	Vendor Name	Description	Amount
Bank FIRE FIRE FUND					
03/22/2016	FIRE	22650	AUTO VALUE YPSILANTI	ROTORS/BRAKES U11-1	171.47
03/22/2016	FIRE	22651	BLUE CROSS/BLUE SHIELD-M	MEDICAL INSURANCE - APRIL 16	8,346.25
03/22/2016	FIRE	22652	CONSUMERS LIFE INSURANCE CO	LIFE INSURANCE - APRIL 16	102.15
03/22/2016	FIRE	22653	CORRIGAN OIL COMPANY	248.7 GALLONS DIESEL	427.93
03/22/2016	FIRE	22654	DELTA DENTAL	DENTAL INSURANCE - APRIL 2016	923.94
03/22/2016	FIRE	22655	EMERGENCY VEHICLES PLUS	LADDER 11-1 REPAIR	3,439.97
03/22/2016	FIRE	22656	LOGOS, INC.	FLOWSTOP GOLFBALL CONTAINMENT PLUGS	315.00
03/22/2016	FIRE	22657	NEW PIG CORPORATION	FUEL SPILL EQUIPMENT	618.15
03/22/2016	FIRE	22658	PAETEC	TELEPHONES STATION #2 - APRIL 2016	76.53
03/22/2016	FIRE	22659	PRIORITY ONE EMERGENCY	RED/WHITE SCENE TAPE	134.99
03/22/2016	FIRE	22660	SUPERIOR TWP PAYROLL FUND	CASH TRANSFER 3/24/16 PAYROLL	28,605.16
03/22/2016	FIRE	22661	VISION SERVICE PLAN	VISION INSURANCE - APRIL 16	187.00
03/29/2016	FIRE	22662	ANN ARBOR WELDING SUPPLY	MEDICAL OXYGEN TANK RENTAL	6.38
03/29/2016	FIRE	22663	AUTO VALUE YPSILANTI	PARTS FOR BRAKES UL-11-1	197.76
03/29/2016	FIRE	22664	BATTERIES PLUS	BATTERY FOR CD MONITOR	6.50
03/29/2016	FIRE	22665	COMCAST	INTERNET SERVICES STATION #2 - APRIL 201	189.56
03/29/2016	FIRE	22666	CONGDON'S ACE HARDWARE	PLEXIGLAS FOR WALL MAP FOR CHIEF'S OFFIC	49.49
03/29/2016	FIRE	22667	DTE ENERGY	GAS - SATION #1 - MAR 2016	589.70
03/29/2016	FIRE	22668	HERKIMER RADIO SERVICE	REPLACE FIRE ALERT SYSTEM - STATION #1	1,331.55
03/29/2016	FIRE	22669	PAETEC	TELEPHONES STATION #1 - MARCH 2016	145.00
03/29/2016	FIRE	22670	RICOH USA, INC	COPIER LEASE - MARCH 2016	385.00
03/29/2016	FIRE	22671	RUSS GIRBACH	CPR REFRESHER COURSE	570.00
03/29/2016	FIRE	22672	SAVANTHA TROTTER	MISC FILING @ FIRE STATION	59.35
03/29/2016	FIRE	22673	SPEARS FIRE & SAFETY	FIRE EXTINGUISHER CHECK FOR TRUCKS	1,112.39
03/29/2016	FIRE	22674	SUPERIOR TOWNSHIP CREDIT CARD ACCT	FINAL PAYMENT FOR A2 NEWS - SCRIPT CANCE	9,644.84
03/29/2016	FIRE	22675	SUPERIOR TWP PAYROLL FUND	PENSION/HCSF - MARCH 2016	1,570.00
03/29/2016	FIRE	22676	TIME EMERGENCY EQUIPMENT	REPLACEMENT FIRE NOZZLES	65.21
04/05/2016	FIRE	22677	ANN ARBOR WELDING SUPPLY	MEDICAL OXYGEN	73.90
04/05/2016	FIRE	22678	COMCAST	INTERNET SERVICES - STATION #1 - APRIL 2	285.54
04/05/2016	FIRE	22679	CORRIGAN OIL COMPANY	169.9 GALLONS DIESEL FUEL	1,533.94
04/05/2016	FIRE	22680	DTE ENERGY	ELECTRIC @ STATION #1 - MAR 2016	365.92
04/05/2016	FIRE	22681	HERKIMER RADIO SERVICE	REPAIR/REPROGRAM RADIO	233.91
04/05/2016	FIRE	22682	PAYETTE SALES & SERVICE, INC.	GAUGE FOR E11-1	47.99
04/05/2016	FIRE	22683	PRIORITY ONE EMERGENCY	WIRE DC MOUNTING RACK (LITEBOX) ORANGE	833.33
04/05/2016	FIRE	22684	SUPERIOR TWP GENERAL FUND	ACCOUNTING FEES - APRIL 2016	41,344.51
04/05/2016	FIRE	22685	SUPERIOR TWP PAYROLL FUND	HSA FEES - 2016	96,756.45
04/05/2016	FIRE	22686	SUPERIOR TWP UTILITY DEPARTMENT	2013 BOND	124.27
04/05/2016	FIRE	22687	TIMOTHY WINTERS	HEALTH INSURANCE REIMBURSEMENT - APRIL 2	664.06
04/05/2016	FIRE	22688	VERIZON WIRELESS	CELL PHONES - MARCH 2016	185.62
04/12/2016	FIRE	22689	CORRIGAN OIL COMPANY	119.7 GALLONS DIESEL	1,737.50
04/12/2016	FIRE	22690	EMERGENT HEALTH PARTNERS	APRIL 2016	175.00
04/12/2016	FIRE	22691	HERKIMER RADIO SERVICE	REPROGRAMMED STATION #2 FEDERAL INFORMER	130.67
04/12/2016	FIRE	22692	PHILIP W. DICKINSON	HEALTH INSURANCE REIMBURSEMENT FOR THE M	

FIRE TOTALS:

Total of 43 Checks:
 Less 0 Void Checks:

203,946.81
 0.00

Total of 43 Disbursements:

203,946.81

Superior Township Utility Department

Check Register

March 22 through April 18, 2016

10:13 AM

04/14/16

Accrual Basis

Date	Num	Name	Memo	Amount
100 - CASH - O&M				
03/22/16	9760	Blue Cross Blue Shield	Medical Insurance - April 16	(4,544.84)
03/22/16	9761	Consumer's Life Insurance Company	Life Insurance - April 16	(71.51)
03/22/16	9762	Delta Dental Plan of Michigan	Dental Insurance - April 16	(488.75)
03/22/16	9763	Ed's Garage, Inc.	REAR BRAKES - GMC 2500	(331.00)
03/22/16	9764	Pitney Bowes	Postage Meter Lease - 1st/16	(434.37)
03/22/16	9765	Stericycle Communications	Answering Service - March 16	(223.79)
03/22/16	9766	UIS	Troubleshoot Sec. 36 Lift Station	(320.00)
03/22/16	9767	Vision Service Plan	Vision Insurance - April 16	(98.34)
03/22/16	9768	Windstream	Phones - Adm. Bldg. - Mar 16	(239.45)
03/22/16	9769	Ypsilanti Comm. Utilities Authority	Water - Adm. Bldg. - Jan-Feb 16	(52.95)
03/29/16	9770	AI's Cleaning Service	Adm. Bldg. Cleaning (5 weeks)	(200.00)
03/29/16	9771	AT&T	Booster Sta. Phone - Mar16	(106.08)
03/29/16	9772	Classic T's	Uniforms	(105.00)
03/29/16	9773	Comcast	Internet - Maint. Fac. - Mar16	(109.85)
03/29/16	9774	Home Depot	Misc supplies	(324.23)
03/29/16	9775	Kennedy Industries, Inc.	Preventative Maintenance at Sect. 36	(995.00)
03/29/16	9776	MacFarland Painting	Geddes Rd. Booster Sta. Painting	(1,794.23)
03/29/16	9777	Rolland Cement	Driveway & Sidewalk Work - 5798 Hampshire	(1,500.00)
03/29/16	9778	Spears Fire and Safety	Fire Extinguisher Inspection & New Ext. for Pole Barn	(154.05)
03/29/16	9779	Superior Twp. General Fund	Payroll - 03/24/15	(17,130.82)
03/29/16	9780	Superior Twp. Payroll Fund	Pension & HCSP - Mar16	(4,608.08)
03/29/16	9781	Verizon	Cell Phones - Mar16	(378.60)
04/05/16	9782	Auto-Wares Group (Auto Value)	Mirror/Battery	(157.32)
04/05/16	9783	Congdon's Ace Hardware	Misc. Shop Supplies	(99.62)
04/05/16	9784	Cummins Bridgeway, LLC	Generator inspections	(1,096.02)
04/05/16	9785	DTE	Gas/Elec - Mar 16	(2,855.36)
04/05/16	9786	Duraweld Industries, Inc.	Vice Mounts (2)	(180.00)
04/05/16	9787	J's Tree Trimming & Removal	Tree Trimming - MacArthur ROW	(1,200.00)
04/05/16	9788	Knaphelde Truck Eq.	Vice mounts	(231.05)
04/05/16	9789	Millennium Business Systems	Toshiba Copier Lease - Mar16 + Supplies	(944.67)
04/05/16	9790	Purchase Power	Postage Meter Refill	(500.00)
04/05/16	9791	R.D. Kleinschmidt	Reattached Shingles on Adm. Bldg.	(85.00)
04/05/16	9792	Staples Advantage	Office Supplies	(234.98)
04/05/16	9793	Wex Bank	Fuel - Mar 16	(209.07)
04/11/16	EFT	Magic-Wrighter	Monthly Fee - Mar16	(67.31)
04/12/16	9794	Cintas Corporation	First Aid Supply Restock	(182.73)
04/12/16	9795	Comcast	Internet - Adm. Bldg. - Mar16	(104.85)

Superior Township Utility Department

Check Register

March 22 through April 18, 2016

10:13 AM

04/14/16

Accrual Basis

Date	Num	Name	Memo	Amount
04/12/16	9796	Congdon's Ace Hardware	Sprayer	(21.97)
04/12/16	9797	Delux Tents & Events, LLC	Flag	(156.50)
04/12/16	9798	DTE	Gas-Elec Feb-Mar 16	(288.36)
04/12/16	9799	Occupational Health Centers of Michigan	DOT Recertification - Allen	(71.50)
04/12/16	9800	Staples Credit Plan	Office Supplies	(443.79)
04/12/16	9801	Superior Twp. General Fund	Payroll - 04/07/16	(16,754.35)
04/12/16	9802	Superior Twp. Payroll Fund	HSA Fees - Apr16	(30.00)
04/12/16	9803	Windstream	Phones - Maint. Fac. - Apr16	(203.65)
04/12/16	9804	Ypsilanti Comm. Utilities Authority	W/S Purch. - AR Properties - Mar16	(350.56)
Total 101 · Checking - Chase 205000485529				(60,679.60)
Total 100 · CASH - O&M				(60,679.60)
120 · CASH - CAPITAL RESERVE				
125 · CR Chkg. - Chase 639918234				
125-YC · Cap. Reserves Checking - YCUA				
03/29/16	540	Ypsilanti Comm. Utilities Authority	2010 Bond Payment	(22,206.39)
04/05/16	541	The Bank of New York Mellon	2013 Bond Payment	(225,750.00)
Total 125-YC · Cap. Reserves Checking - YCUA				(247,956.39)
Total 125 · CR Chkg. - Chase 639918234				(247,956.39)
Total 120 · CASH - CAPITAL RESERVE				(247,956.39)
TOTAL				(308,635.99)

**SUPERIOR CHARTER TOWNSHIP EMPLOYMENT OPPORTUNITY
POSITION DESCRIPTION
PARKS AND RECREATION SPECIAL PROJECTS COORDINATOR**



STATUS: Part Time (4 hours per week)

RATE OF PAY: Based on Qualifications

RESPONSIBLE TO: Parks & Recreation Administrator

SUMMARY: This is a part time position that will be responsible for assisting with various special projects associated with the Building Healthy Communities grant and other duties as assigned by the Parks & Recreation Administrator.

Responsibilities:

- This position will assist with coordinating the Come Out And Play Park Leader I employee, Come Out And Play Park Leader II employees, and the Walk With Ease Leader employee
- Assist with grant reporting and other administrative duties associated with the grant.
- Assist with Walk With Ease (WWE) and Come Out And Play (COAP) programs as needed.
- Investigate and/or work towards creating a “smoke-free” ordinance for all Township Parks
- Work on special projects and other duties as assigned by the Parks & Recreation Administrator.

Qualifications

- Ability to communicate effectively in both written and oral form.
- Previous experience with grant reporting.
- Ability to develop and maintain effective working relationships with other department employees and seasonal employees/interns.
- Proficient in the operation of a PC using such software as Microsoft Office and other programs used by the department.
- Must be able to become CPR Certified prior to start of WWE and COAP programs.
- Must be able to become certified by the Arthritis Foundation to present the WWE program.
- Able to use good judgment and decision making skills as it relates to program participants.

Interested candidates should send a letter of interest along with their resume to:

Superior Township Parks & Recreation

575 E. Clark

Ypsilanti, MI 48198

Attn: Juan Bradford, P&R Administrator

Or by email to: superiorparks@superior-twp.org

For additional information call Juan Bradford, P&R Administrator at: (734) 480-5502

Letters and Resumes will be accepted through Friday, April 15, 2016

**SUPERIOR CHARTER TOWNSHIP EMPLOYMENT OPPORTUNITY
POSITION DESCRIPTION
COME OUT AND PLAY LEADER I**

FYI

STATUS: Seasonal Part-Time (8-16 hours per week)

RATE OF PAY: \$10.00 per hour

RESPONSIBLE TO: Parks & Recreation Administrator
Parks & Recreation Special Projects Coordinator

SUMMARY: This is a seasonal part-time position that will be responsible for presenting the daily Come out and Play (COAP) park activities to resident youths.

Responsibilities:

- This position will present the COAP activities to resident youths.
- Provide a safe & structured play environment for resident youths.
- Educate resident youths on the importance of health and fitness as outlined in the COAP curriculum.
- Other duties as assigned by the Parks & Recreation Administrator, Special Projects Coordinator or Come out and Play Leader II.

Qualifications:

- Ability to communicate effectively in both written and oral form.
- Ability to develop and maintain effective working relationships with other department employees and seasonal employees.
- Proficient in the operation of a PC using such software as Microsoft Office and other programs used by the department.
- Must be able to become CPR Certified prior to start of COAP program.
- Able to use good judgment and decision making skills as it relates to program participants.

Interested candidates should send a letter of interest along with their resume to:

Superior Township Parks & Recreation

575 E. Clark

Ypsilanti, MI 48198

Attn: Juan Bradford, P&R Administrator

Or by email to: superiorparks@superior-twp.org

For additional information call Juan Bradford, P&R Administrator at: (734) 480-5502

Letters and Resumes will be accepted through Friday, April 15, 2016

**SUPERIOR CHARTER TOWNSHIP EMPLOYMENT OPPORTUNITY
POSITION DESCRIPTION
COME OUT AND PLAY LEADER II**



STATUS: Seasonal Part-Time (8-16 hours per week)

RATE OF PAY: \$12.00 per hour

RESPONSIBLE TO: Parks & Recreation Administrator
Parks & Recreation Special Projects Coordinator

SUMMARY: This is a seasonal part-time position that will be responsible for presenting the daily Come out and Play (COAP) park activities to resident youths.

Responsibilities:

- This position will present the COAP activities to resident youths.
- Provide a safe & structured play environment for resident youths.
- Educate resident youths on the importance of health and fitness as outlined in the COAP curriculum.
- Other duties as assigned by the Parks & Recreation Administrator, Special Projects Coordinator or Come out and Play Leader II.
- Assist with scheduling and supervision of Come out and Play Leader I employees

Qualifications:

- Ability to communicate effectively in both written and oral form.
- Ability to develop and maintain effective working relationships with other department employees and seasonal employees.
- Proficient in the operation of a PC using such software as Microsoft Office and other programs used by the department.
- Must be able to become CPR Certified prior to start of COAP program.
- Able to use good judgment and decision making skills as it relates to program participants.

Interested candidates should send a letter of interest along with their resume to:

Superior Township Parks & Recreation

575 E. Clark

Ypsilanti, MI 48198

Attn: Juan Bradford, P&R Administrator

Or by email to: superiorparks@superior-twp.org

For additional information call Juan Bradford, P&R Administrator at: (734) 480-5502

Letters and Resumes will be accepted through Friday, April 15, 2016

**SUPERIOR CHARTER TOWNSHIP EMPLOYMENT OPPORTUNITY
POSITION DESCRIPTION
WALK WITH EASE LEADER**

FYI

STATUS: Seasonal Part-Time (6 hours per week)

RATE OF PAY: \$15.00 per hour

RESPONSIBLE TO: Parks & Recreation Administrator
Parks & Recreation Special Projects Coordinator

SUMMARY: This is a seasonal part-time position that will be responsible for preparing and presenting the Arthritis Foundation's Walk With Ease (WWE) program to resident seniors and adults.

Responsibilities:

- Present the Arthritis Foundation's WWE program to resident seniors and adults.
- Provide a safe & structured program for participants.
- Educate participants on the importance of health and fitness through walking as outlined in the WWE curriculum.
- Other duties as assigned by the Parks & Recreation Administrator or Special Projects Coordinator.

Qualifications:

- Ability to communicate effectively in both written and oral form.
- Ability to develop and maintain effective working relationships with other department employees and seasonal employees.
- Proficient in the operation of a PC using such software as Microsoft Office and other programs used by the department.
- Must be able to become CPR Certified prior to start of WWE.
- Must be able to become Certified by the Arthritis Foundation to present the WWE Program.
- Able to use good judgment and decision making skills as it relates to program participants.

Interested candidates should send a letter of interest along with their resume to:

Superior Township Parks & Recreation

575 E. Clark

Ypsilanti, MI 48198

Attn: Juan Bradford, P&R Administrator

Or by email to: superiorparks@superior-twp.org

For additional information call Juan Bradford, P&R Administrator at: (734) 480-5502

Letters and Resumes will be accepted through Friday, April 15, 2016

FYI

SUPERIOR TOWNSHIP PARKS & RECREATION

is looking for your input on
Fireman's Park.

What new features would
you like to see added to
the park?

- ✓ Play structure for 2-5 year olds
- ✓ Play structure for 5-12 year olds
- ✓ Swings
- ✓ Merry-go-round
- ✓ Adult fitness equipment
- ✓ Walking path
- ✓ ???

Let us know how we can improve your
park by sending us an email at:

superiorparks@superior-twp.org

Thank you for helping to making your
Township Parks Superior!!!



FYI

Washtenaw County Road Commission
555 N. Zeeb Road
Ann Arbor, Michigan 48103

PRESS RELEASE

FOR IMMEDIATE RELEASE: 03/31/2016

Contact:

Katie Parrish, Communications Coordinator
(734) 864-2999, parrishk@wcroads.org

WCRC TO RECEIVE \$500,000 TO FUND GEDDES RD SAFETY IMPROVEMENTS

Superior Township, MI—The Washtenaw County Road Commission has received approximately \$500,000 in federal safety funds to improve safety features on Geddes Road between Leforge Road and Prospect Rd in 2017.

The project involves a culvert replacement and installation of new guardrails, as well as the addition of center-line rumble strips. These improvements will address the prevailing crash types, and the Road Commission expects to see reduced crash rates along Geddes Road.

The Road Commission will use the safety funds to bring the guardrail up to standard and improve its stability, which will require a larger cross-section at the bridge and an improved slope. The present day short-span bridge located over the Snidecar Drain will be replaced with a longer concrete box-culvert, which will allow the Road Commission to create a proper slope and extend the guardrail along Geddes Road, both of which will improve the stability of the guardrail.

Additionally, WCRC will install centerline rumble strips on Geddes Road between Leforge Road and Prospect Road due to the history of cross-centerline crashes.

-###-



EVAN N. PRATT, P.E.

WATER RESOURCES COMMISSIONER
705 North Zeeb Road
P.O. Box 8645
Ann Arbor, MI 48107-8645

email: drains@ewashtenaw.org
<http://drain.ewashtenaw.org>

MEGHAN BONFIGLIO
Chief Deputy Water Resources Commissioner

HARRY SHEEHAN
Deputy Water Resources Commissioner

Telephone 734.222.686
Fax 734.222.6803

March 23, 2016

FYI

David M. Phillips, Clerk
Superior Township
3040 N. Prospect Rd
Ypsilanti, MI 48198

Subject: 2016-2017 Increased inspection activity in and around county drains

David M.;

Beginning this spring and continuing through the fall of 2017, the Water Resources Office will be conducting assessments of county drains and stormwater basins throughout Washtenaw County. Our crews may be accompanied by a truck equipped to conduct video inspection of our critical pipe systems. Staff and/or contract employees will have proper identification and will be wearing high-visibility safety vests.

During this time, we may be more visible to residents or be noticed at locations that typically don't see much activity. So in the coming months you may receive inquiries about our activity. Please provide this summary to the staff that is responsible for answering resident calls.

While we've collected a great deal of information over the years, we don't have consistent, comprehensive data on every mile of our 533 county drains. Information collected will allow for more efficient response to service requests, a more strategic approach to periodic maintenance and an increased reliance on proactive maintenance to prevent costly repairs. The goal is to identify and address small problems before they become big ones, and limit or delay reactive projects that result in higher drain assessments.

This effort will also improve customer communication and decision making. It will allow our front office and field staff more immediate access to GIS maps, photos, condition ratings, and work activity. Our ability to quickly and accurately respond to our customer queries should be greatly enhanced. Much of this information will be made available for public and municipal use via the County's publicly available GIS system at [MapWashtenaw](#).

We are currently in data collection mode. Once the condition assessments are more complete, we'll be better capable of identifying options and working with you to prioritize projects in a manner consistent with your community's cost expectations. In 6-8 months' time, we will be ready to review our findings and discuss options for improving cost effectiveness relative to a 5-year history of past assessments.

FYI



Public Hearing Notice

**City of Ypsilanti Planning Commission
Wednesday, 20 April 2016, 7:00 p.m.
Council Chambers, City Hall**

The City of Ypsilanti Planning Commission will hold a public hearing on Wednesday, 20 April 2016, at 7:00 p.m. in the Council Chambers of the City Hall, One South Huron Street, Ypsilanti, Michigan 48197. The purpose of the hearing will be to receive public comments on the following:

Special Use Permit: 734 N River St

The Planning Commission will hear a presentation, hold a public hearing, and make a determination regarding an application for a special use permit at 734 N River St. The parcel is currently zoned **CN-Mid, Core Neighborhood Mid**. The applicant is requesting a special use permit for a multiple family dwelling with a maximum of 4 units. The address, parcel number, and legal description of the parcel are:

- **734 N River:** 11-11-04-410-001, YP CITY 3E-14 LOT 15 ASSESSOR'S PLAT NO. 7. ALSO, THE SOUTH ONE-HALF OF THE VACATED ALLEY ABBUTTING ON THE NORTH.

The City invites all citizens to attend this meeting or to send written comments to the City of Ypsilanti, Community & Economic Development Department, One South Huron Street, Ypsilanti, Michigan 48197. For further information, please call 734-483-9646 or email wesslerb@cityofypsilanti.com. Planning Commission packets, including staff reviews and digital plans when possible, are available at cityofypsilanti.com/PlanningCommission. For a full calendar of City events, please go to our website at cityofypsilanti.com/calendar.aspx.

The City of Ypsilanti will provide necessary auxiliary aids and services, such as signers for people with hearing disabilities or audio tapes of printed materials for people with vision disabilities, upon two days' notice to the City of Ypsilanti. Those requiring these aids or services should contact the City of Ypsilanti at:

City Clerk's Office
One South Huron Street
Ypsilanti, Michigan 48197
(734) 483-1100

Frances McMullan
City Clerk

LANDLORDS, PLEASE POST THIS INFORMATION FOR YOUR TENANTS.

FYI



Public Hearing Notice

City of Ypsilanti Planning Commission Wednesday, 20 April 2016, 7:00 p.m. Council Chambers, City Hall

The City of Ypsilanti Planning Commission will hold a public hearing on Wednesday, 20 April 2016, at 7:00 p.m. in the Council Chambers of the City Hall, One South Huron Street, Ypsilanti, Michigan 48197. The purpose of the hearing will be to receive public comments on the following:

Special Use Permit: 298 Jarvis

The Planning Commission will hear a presentation, hold a public hearing, and make a determination regarding an application for a special use permit at 298 Jarvis. The parcel is currently zoned **GC- General Corridor**. The applicant is requesting a special use permit to build an automobile storage facility. The address, parcel numbers, and legal description of the parcels are:

- **298 Jarvis:** all of parcel 11-11-04-341-002 and the southeast portions of parcels 11-11-04-341-003 and 11-11-04-335-001, Part of the SW ¼ of Section 4, T.3S., R.7E., City of Ypsilanti, Washtenaw County Michigan, also part of lots 1 and 2, all of Lots 9 through 13, all of lots 15 through 17, lot 24, lot 27, part of vacated St. John's Street, the East ½ of Adams Street adjoining lots 9 and 10 vacated by the City of Ypsilanti, in the year 1904, and all that portion of St. John 's Street and Adams Street adjoining said lots of "Scovill and Tuttle Subdivision" as recorded in Liber 1 of Plats, Page 26, Washtenaw County Records, of Lots 9, 10, 11, 12, 13, 39, a part of Lots 38 and 40, and a portion of unnumbered land Southeast of the numbered Lots in Jarvis' Original Addition to Ypsilanti in the SW ¼ of Section 4, T3S, R7E, as recorded in Liber 1 of Plats, Page 26, Washtenaw County Records, being more particularly described as: Commencing at the Southwest corner of said Lot 27; thence, N 11° 44' 54" W, 155.35 feet; thence N 78° 50' 41" E, 173.16 feet; thence N 50° 36' 09" E, 174.74 feet; thence 137.60 feet along an arc of a curve to the right, (radius 978.03 feet, central angle 08° 03' 40", chord bears S 40° 06' 16" E, 137.49 feet); thence 275.83 feet along an arc of a curve to the right, (radius 849.86 feet, central angle 18° 35' 45", chord bears S 28° 07' 21" E, 274.62 feet); thence S 78° 15' 06" W, 221.40 feet; thence, N 11° 44' 54" W, 119.84 feet; thence S 78° 12' 27" W, 30.00 feet; thence S 78° 15' 06" W, 110.06 feet; thence N 11° 44' 54" W, 30.00 feet; thence S 78° 15' 06" W 109.20 feet to the point of beginning. Containing 106,404 square feet or 2.443 acres.

The City invites all citizens to attend this meeting or to send written comments to the City of Ypsilanti, Community & Economic Development Department, One South Huron Street, Ypsilanti, Michigan 48197. For further information, please call 734-483-9646 or email wesslerb@cityofypsilanti.com. Planning Commission packets, including staff reviews and digital plans when possible, are available at cityofypsilanti.com/PlanningCommission. For a full calendar of City events, please go to our website at cityofypsilanti.com/calendar.aspx.

The City of Ypsilanti will provide necessary auxiliary aids and services, such as signers for people with hearing disabilities or audio tapes of printed materials for people with vision disabilities, upon two days' notice to the City of Ypsilanti. Those requiring these aids or services should contact the City of Ypsilanti at:

City Clerk's Office
One South Huron Street
Ypsilanti, Michigan 48197
(734) 483-1100

Frances McMullan
City Clerk

LANDLORDS, PLEASE POST THIS INFORMATION FOR YOUR TENANTS.



FYI

Public Hearing Notice

**City of Ypsilanti Planning Commission
Wednesday, 20 April 2016, 7:00 p.m.
Council Chambers, City Hall**

The City of Ypsilanti Planning Commission will hold a public hearing on Wednesday, 20 April 2016, at 7:00 p.m. in the Council Chambers of the City Hall, One South Huron Street, Ypsilanti, Michigan 48197. The purpose of the hearing will be to receive public comments on the following:

Special Use Permit: 436 Orchard

The Planning Commission will hear a presentation, hold a public hearing, and make a determination regarding an application for a special use permit at 436 Orchard. The parcel is currently zoned **R-1, Single Family Residential**. The applicant is requesting a special use permit for a group child care home. The address, parcel number, and legal description of the parcel are:

- **436 Orchard:** 11-11-39-433-011, YP CITY 1-W222 PCL "B" COM AT NW COR FREDERICK & ORCHARD STS, TH N 193.00 FT TO POB, TH W 125.00 FT, TH N 61.00 FT, TH E 125.00 FT, TH S 61.00 FT TO POB. PT OF LOTS 122 & 123 WORDEN CITY GARDEN SUB. (UNRECORDED)

The City invites all citizens to attend this meeting or to send written comments to the City of Ypsilanti, Community & Economic Development Department, One South Huron Street, Ypsilanti, Michigan 48197. For further information, please call 734-483-9646 or email wesslerb@cityofypsilanti.com. Planning Commission packets, including staff reviews and digital plans when possible, are available at cityofypsilanti.com/PlanningCommission. For a full calendar of City events, please go to our website at cityofypsilanti.com/calendar.aspx.

The City of Ypsilanti will provide necessary auxiliary aids and services, such as signers for people with hearing disabilities or audio tapes of printed materials for people with vision disabilities, upon two days' notice to the City of Ypsilanti. Those requiring these aids or services should contact the City of Ypsilanti at:

City Clerk's Office
One South Huron Street
Ypsilanti, Michigan 48197
(734) 483-1100

Frances McMullan
City Clerk

LANDLORDS, PLEASE POST THIS INFORMATION FOR YOUR TENANTS.



JERRY L. CLAYTON
SHERIFF

WASHTENAW COUNTY OFFICE OF THE SHERIFF



MARK A. PTASZEK
UNDERSHERIFF

2201 Hogback Road • Ann Arbor, Michigan 48105-9782 • OFFICE (734) 971-8400 • FAX (734) 973-4824 • EMAIL sheriff@cwashtenaw.org

EMERGENCY SERVICES DIVISION OUTDOOR WARNING SIREN TEST NOTIFICATION

FYI

Saturday April 2, 2016 at 12:00 Noon

Washtenaw County's 81 warning sirens will be tested at Noon on the first Saturday of every month from March through October. If there is a threat of severe weather on the day of a test, it will be cancelled.

Except for scheduled testing, the sirens will be activated for the following emergencies:

- The National Weather Service has Issued a tornado warning
- A severe thunderstorm has been detected with damaging winds of 75 MPH or greater.
- A hazardous materials accident requires immediate protective action by the public
- An attack on the United States is imminent, underway or has recently occurred

Warning siren activation is a signal to members of the public to immediately go indoors and monitor local Emergency Alert System media outlets for official information. Washtenaw County's emergency broadcasters are:

WEMU 89.1 FM
WWW 102.9 FM
WQKL 107.1 FM
WTKA 1050 AM
WLBY 1290 AM